

BERNINA®



BERNINA® 1011
Electronic

Instructions Manual



BERNINA® 1011
Electronic

Important Safety Instructions

When using an electrical appliance, basic safety precautions should always be followed, including the following:

Read all instructions before using this sewing machine.

DANGER

- To reduce the risk of electric shock:

1. An appliance should never be left unattended when plugged in.
2. Always unplug this appliance from the electric outlet immediately after using and before cleaning.
3. Always unplug before relamping. Replace bulb with same type rated 15 Watts.

WARNING

- To reduce the risk of burns, fire, electric shock, or injury to persons:

1. Do not allow to be used as a toy. Close attention is necessary when this appliance is used by or near children.
2. Use this appliance only for its intended use as described in this manual. Use only attachments recommended by the manufacturer as contained in this manual.
3. Never operate this appliance if it has a damaged cord or plug, if it is not working properly, if it has been dropped or damaged, or dropped into water. Return the appliance to the nearest authorized dealer or service center for examination, repair, electrical or mechanical adjustment.

4. Never operate the appliance with any air openings blocked. Keep ventilation openings of the sewing machine and foot control free from accumulation of lint, dust, and loose cloth.

5. Keep fingers away from all moving parts. Special care is required around the sewing machine needle.

6. Always use the proper needle plate. The wrong plate can cause the needle to break.

7. Do not use bent needles.

8. Do not pull or push fabric while stitching. It may deflect the needle causing it to break.

9. Switch the sewing machine off (←0→) when making any adjustments in the needle area, such as threading needle, changing needle, threading bobbin, or changing presser foot, and the like.

10. Always unplug sewing machine from the electrical outlet when removing covers, lubricating, or when making any other user servicing adjustments mentioned in the instruction manual.

11. Never drop or insert any object into any opening.

12. Do not use outdoors.

13. Do not operate where aerosol (spray) products are being used or where oxygen is being administered.

14. To disconnect, turn all controls to the off (←0→) position, then remove plug from outlet.

15. Do not unplug by pulling on cord. To unplug, grasp the plug, not the cord.

This product must be grounded. In the event of malfunction or breakdown, grounding provides a path of least resistance for electric current to reduce the risk of electric shock. This product is equipped with a cord having an equipment-grounding conductor and a grounding plug. The plug must be plugged into an appropriate outlet that is properly installed and grounded in accordance with all local codes and ordinances.

DANGER

Improper connection of the equipment-grounding conductor can result in a risk of electric shock. The conductor with insulation having an outer surface that is green with or without yellow stripes is the equipment-grounding conductor. If repair or replacement of the cord or plug is necessary, do not connect the equipment-grounding conductor to a live terminal. Check with a qualified electrician or serviceman if the grounding instructions are not completely understood, or if in doubt as to whether the product is properly grounded.

Do not modify the plug provided with the product - if it will not fit the outlet, have a proper outlet installed by a qualified electrician.

This product is for use on a nominal 120 V circuit, and has a grounding plug that looks like the plug illustrated in sketch A. A temporary adaptor, which looks like the adaptor illustrated in sketches B and C, may be used to connect this plug to a

2-pole receptacle as shown in sketch B if a properly grounded outlet is not available. The temporary adaptor should be used only until a properly grounded outlet can be installed by a qualified electrician. The green colored rigid ear, lug, and the like, extending from the adaptor must be connected to a permanent ground such as a properly grounded outlet box cover. Whenever the adaptor is used, it must be held in place by the metal screw.

GROUNDING METHODS

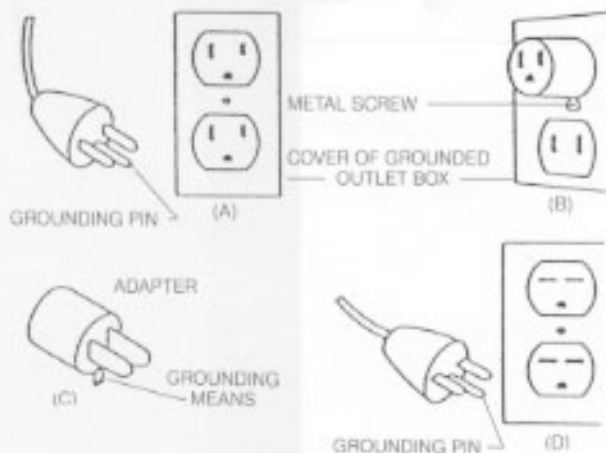



Dear Bernina Customer

Congratulations on choosing a Bernina 1011. You are now the proud owner of a sewing machine which fulfils every expectation in terms of use and quality. You own a first class product which will give you sewing pleasure for many years to come.

Some hundred years ago, my great grandfather invented the first ever hemstitch machine. This was the beginning of the Bernina family business and I am proud to be the fourth generation member of the family to have responsibility for the company. I am delighted to welcome you to the millions of satisfied Bernina owners around the world.

If you require any further information about your sewing machine or sewing in general, please do not hesitate to contact your Bernina dealer, who will be delighted to help you.

I wish you very happy and successful sewing.

Yours truly,

Hanspeter Ueltschi
President

Display / Control panel

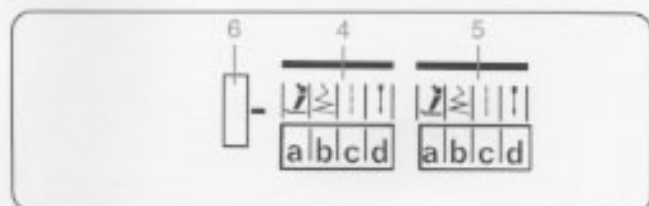
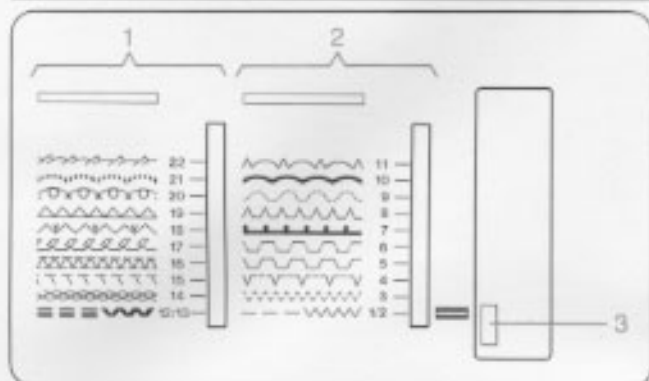

- 1 Red stitch programme
- 2 Green stitch programme
- 3 Selector lever
- 4 Basic setting scale, red stitches
 - a. Presser foot indicator
 - b. Stitch width
 - c. Stitch length
 - d. Needle position
- 5 Basic setting scale, green stitches
 - a. Presser foot indicator
 - b. Stitch width
 - c. Stitch length
 - d. Needle position
- 6 Pattern indicator
- 7 Stitch width knob
- 8 Needle position knob
- 9 Buttonhole knob
- 10 Stitch length knob
- 11 Red-Green stitch programme selector knob
- 12 Feed-dog knob

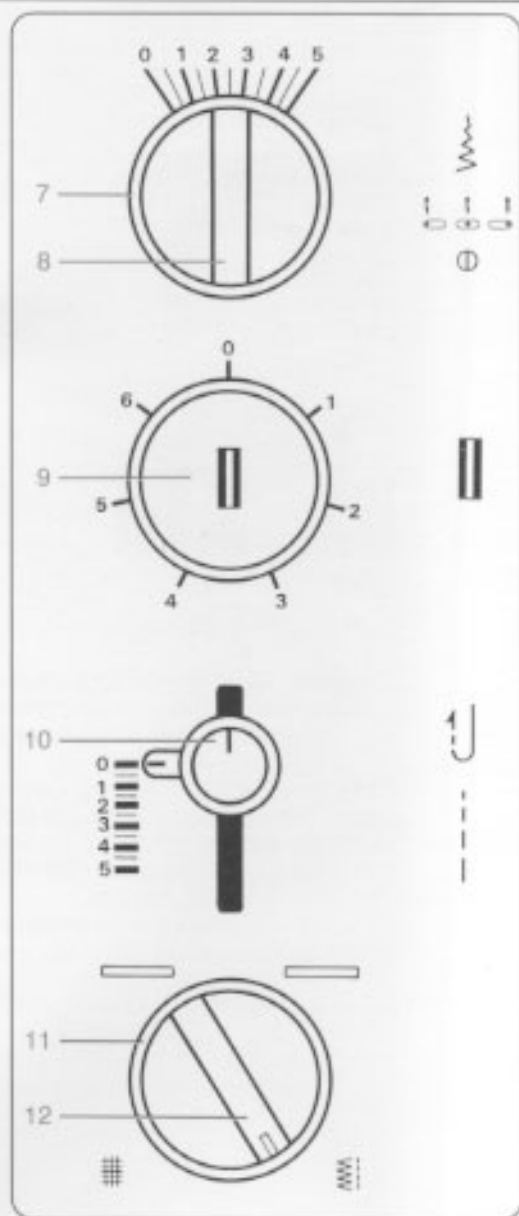

Details of machine

- 1 Hinged front cover
- 2 Stitch plate
- 3 Presser foot
- 4 Needle clamp
- 5 Thread regulator
- 6 Pattern indicator
- 7 Thread take-up lever
- 8 Pre-tension stud
- 9 Thread tension slot
- 10 Adjusting knob for thread tension
- 11 Basic setting scale
- 12 Red stitches
- 13 Green stitches
- 14 Selector lever
- 15 Bobbin spindle
- 16 Engaging lever for bobbin winder
- 17 Handwheel
- 18 Stitch width knob
- 19 Needle position knob
- 20 Power switch
- 21 Buttonhole knob
- 22 Stitch length knob
- 23 Socket for foot control unit/ socket for mains cable
- 24 Securing pins for sewing table
- 25 Indicator for stitch programme (RED-GREEN)
- 26 Stitch programme selector knob
- 27 Selector knob for sewing/darning
- 28 Thread holder pins
- 29 Supplementary thread guide
- 30 Carrying handle
- 31 Thread guide
- 32 Presser foot lever
- 33 Thread cutter



Setting up the sewing machine 1

Threads 9
Needles
Presser feet
Practical stitches
Decorative stitches

Practical sewing 17

Troubleshooting 37
Maintenance

Index 43

Setting up the sewing machine

Cover, Accessories



Cover, accessories

The cover protects the machine from dust and dirt.

The outside pocket provides storage for the instruction manual, foot control and cable.

The machine is very easy to carry with the practical, retractable handle.

Standard accessories

6 bobbins
Needle assortment
Ruler/template
Seam ripper
Small screwdriver
Special screwdriver
Bulb holder
Cleaning brush
Oiler, filled
Seam/quilting guide
Reverse pattern foot
Overlock foot
Blind stitch foot
Buttonhole foot
Zip foot
Darning foot
Darning ring

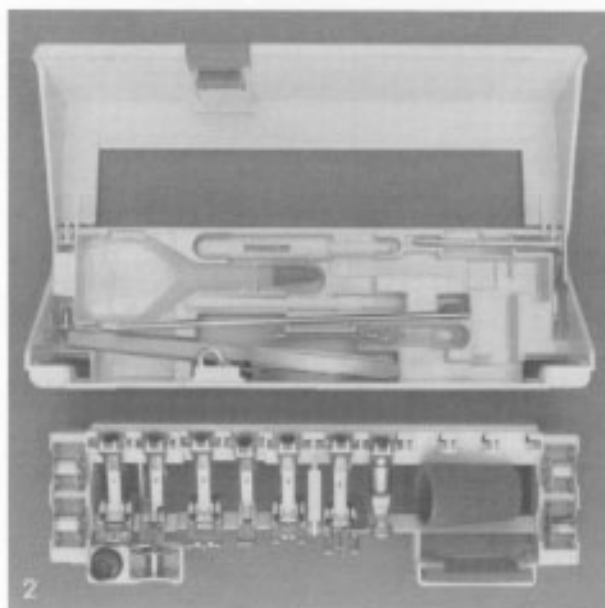

Accessories box

The accessories are neatly stored in the accessories box (Fig. 2).

Fitting the accessories box onto the machine

The accessories box has two fixing lugs that fit into the base plate of the machine.

Removing the accessories box

Simply push the accessories box backwards (Fig. 3).

Lay the accessories box onto the base plate from the rear and press against the free arm until the fixing lugs engage in the holes provided (Fig. 4).

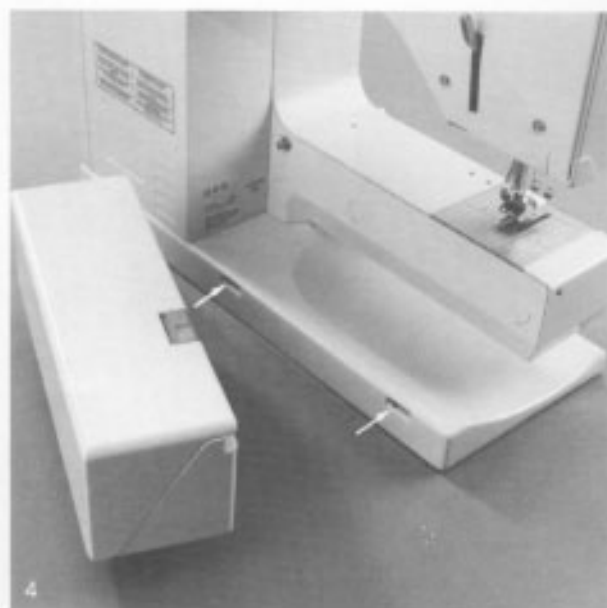
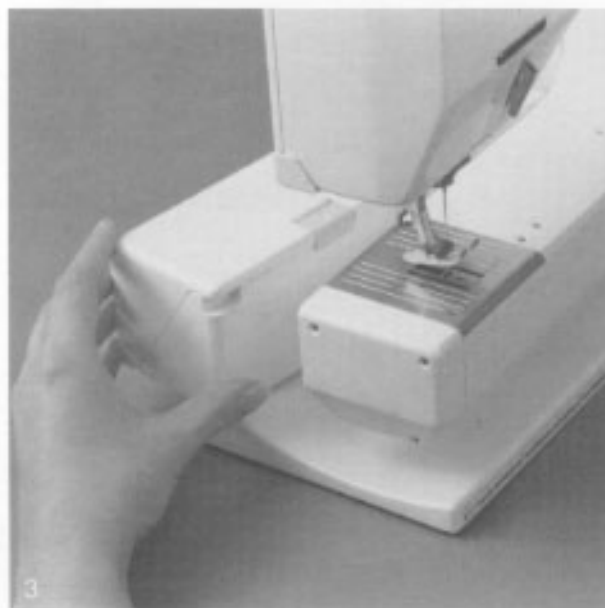

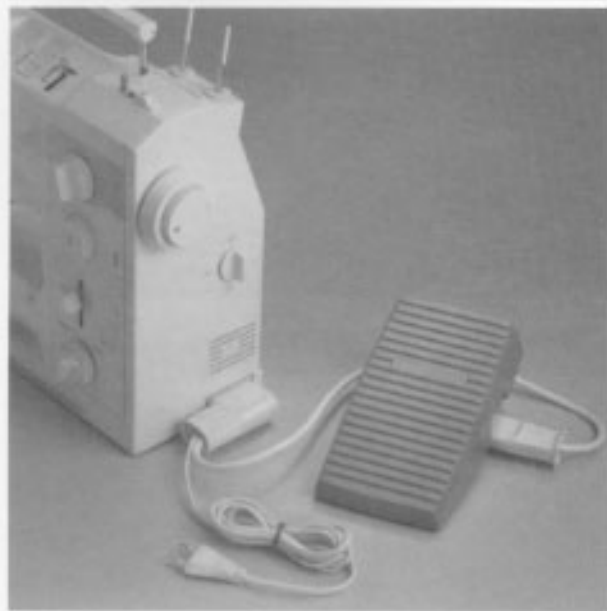

Connecting mains cable and foot control unit

Plug the specially combined mains/foot control cable into the machine. Plug the foot control cable into the foot control and the machine cable into the mains socket.



Foot control unit

This is used to regulate the sewing speed.

The sewing speed can be controlled from virtually 0 to maximum speed by varying the pressure on the plate of the foot control unit.

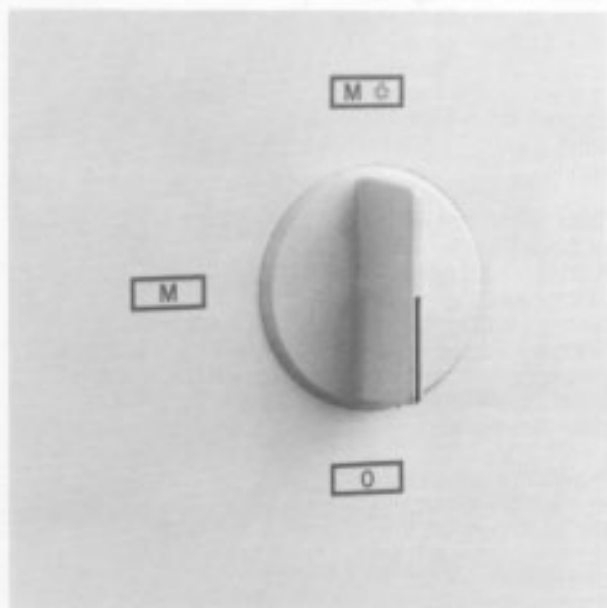

Power switch, sewing light

The power switch below the handwheel has 3 positions:

O Off The machine is switched off.

M On The machine is switched on.

M O The machine and sewing light are switched on.

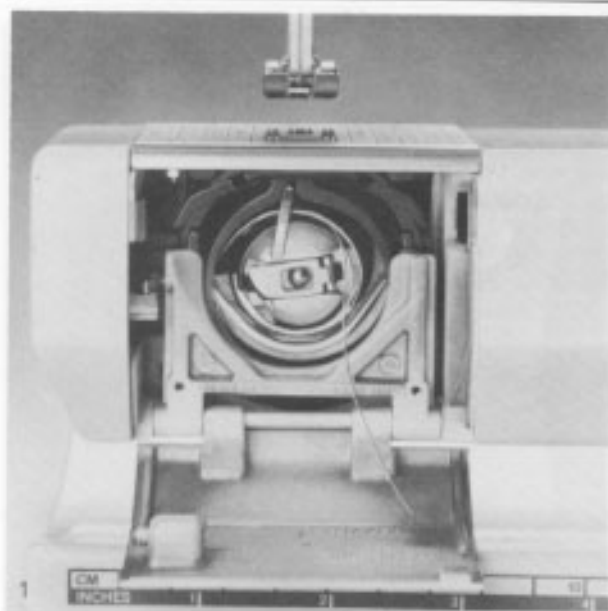

Removing the bobbin case

Set the power switch to the  position.

Check that the needle is raised. Open the hinged front cover on the free arm (Fig. 1).

WARNING:

Please refer to the Safety Instructions.

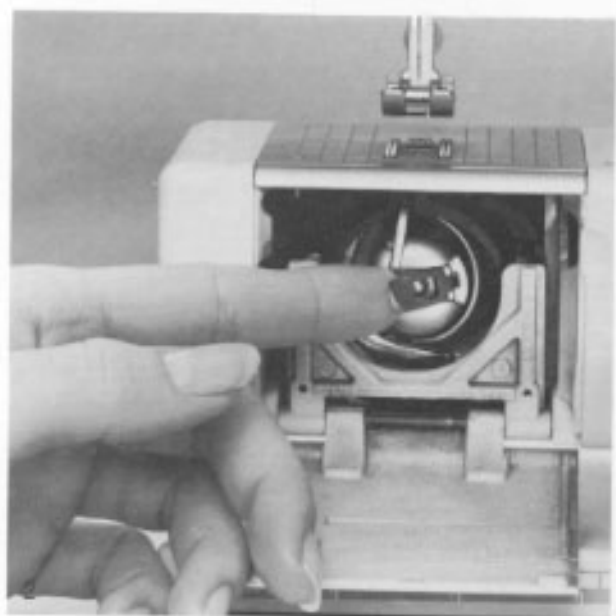

With the index finger and thumb of the left hand, pull the bobbin case latch forward and remove the bobbin case (Fig. 2).



Winding lower thread

Holding the handwheel with the left hand, turn the handwheel release forward with the right hand. The sewing machine is now disengaged (Fig. 3). Place empty bobbin on the spindle and press it to the right against the bobbin winder stop. The bobbin winder is now engaged.

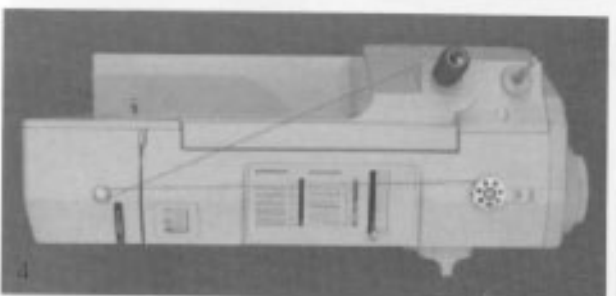

Take thread from the reel of thread on the thread holder pin and pass it clockwise around the pretension stud to the empty bobbin. Wind around the empty bobbin several times, again in a clockwise direction (Fig. 4).



When removing the bobbin, cut the thread by pulling it to the left against the bobbin winder stop (Fig. 5).

Press on the foot control to start the motor. When the bobbin is full, the bobbin winder will stop automatically. Push bobbin to left and remove.

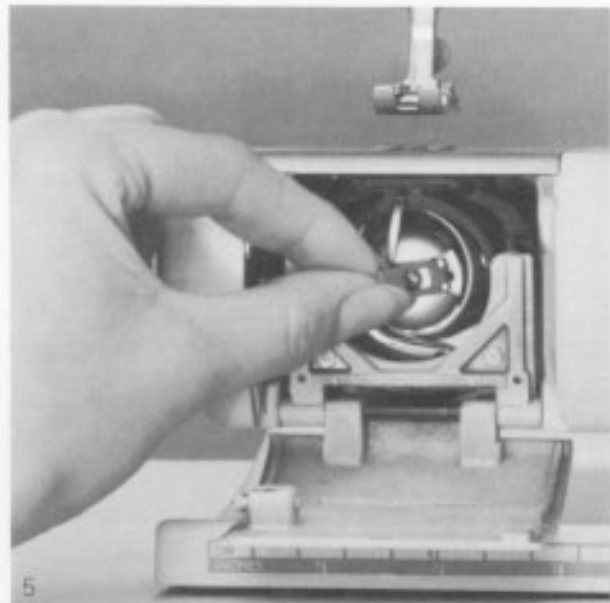

Inserting the bobbin

Hold the bobbin case in the left hand. Insert the bobbin with the thread running in a clockwise direction, see arrow.

Take the thread anti-clockwise to the slot.

Pull the thread into the slot and under the spring, until it lies in the T-shaped slot at the end of the spring.

When the end of the thread is pulled, the bobbin should turn clockwise, in the direction of the arrow.

Inserting the bobbin case into the hook

Hold the bobbin case by the latch with the index finger and thumb of the left hand. Insert so that the finger of the bobbin case points upwards, engaging in the notch of the hook race cover. Check: Pull end of thread. Close the hinged front cover.







Threading the upper thread

Set the power switch to OFF .

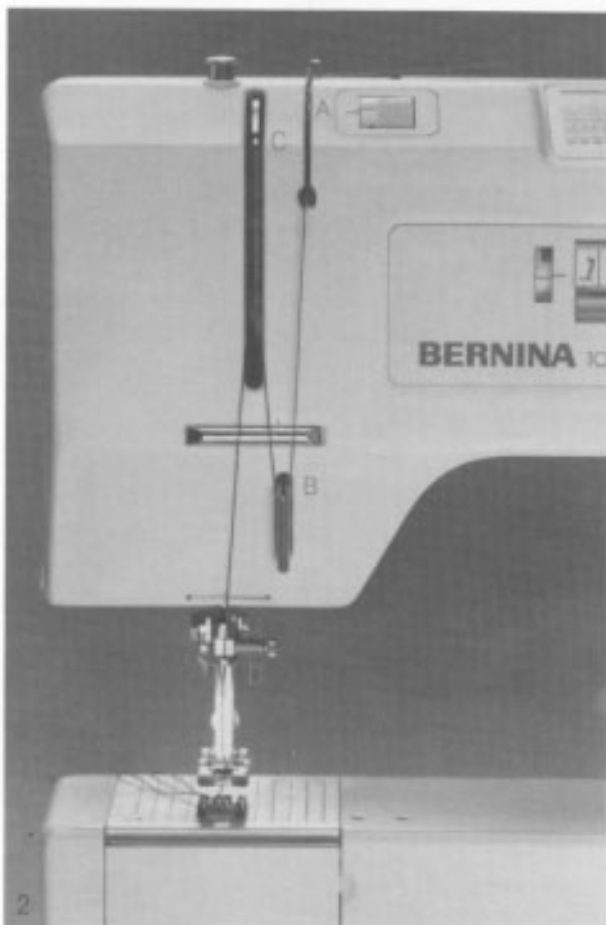
Check that the needle is in the raised position. Raise the presser foot. Place the reel of thread on one of the two thread holder pins. Hold the reel of thread in position while threading.

First clip the thread in the thread guide on the top of the machine. Then pull it through the long slot (A) into the thread tension (Fig. 1).



At the front of the machine, take the thread downwards under the thread regulator , then up to the thread take-up lever at the top , and down again to the needle holder thread guide  (Fig. 2).

Always thread the needle from front to back.

The small white plate on the front of presser foot shank helps when threading the needle eye. Pull the thread approx. 10 cm (4") through the needle eye.

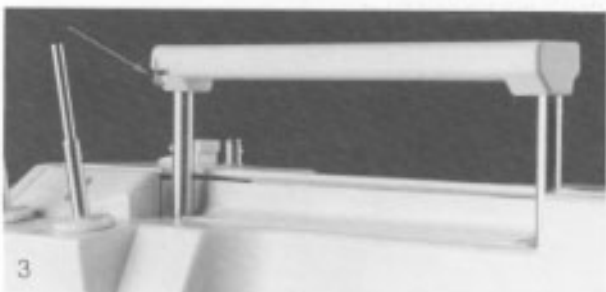

Supplementary thread guide on handle

Sewing with cross-wound reels, metal and silver threads, double or triple needles.

For perfect thread feed, take the thread through the special supplementary thread guide on the handle.

WARNING:

Please refer to the Safety Instructions.

Bringing up the lower thread, thread tension, feed-dog

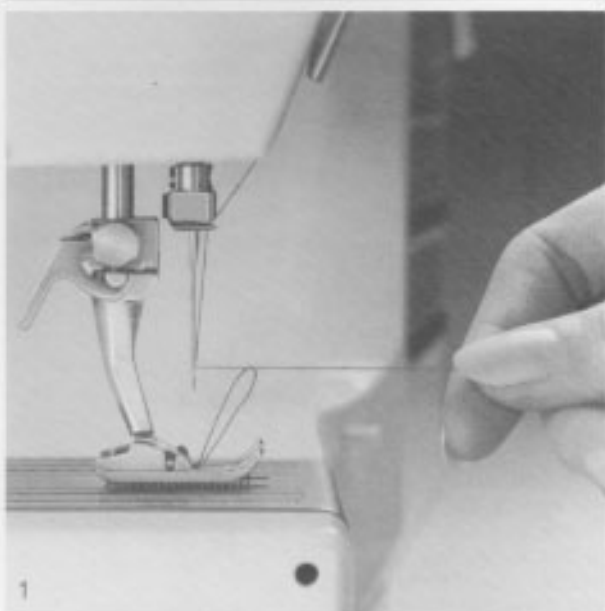

Bringing up the lower thread

Hold the end of the upper thread with the right hand. Sew a single stitch by tapping on the foot control. Pull the upper thread so that the lower thread is brought up through the stitch plate hole (Fig. 1). Take both threads through the slot in the presser foot and place to the side.

Instead of using the needle stop, the lower thread can also be brought up by turning the handwheel forward until the needle returns to its highest position. In this case the upper thread has to be held with the left hand.

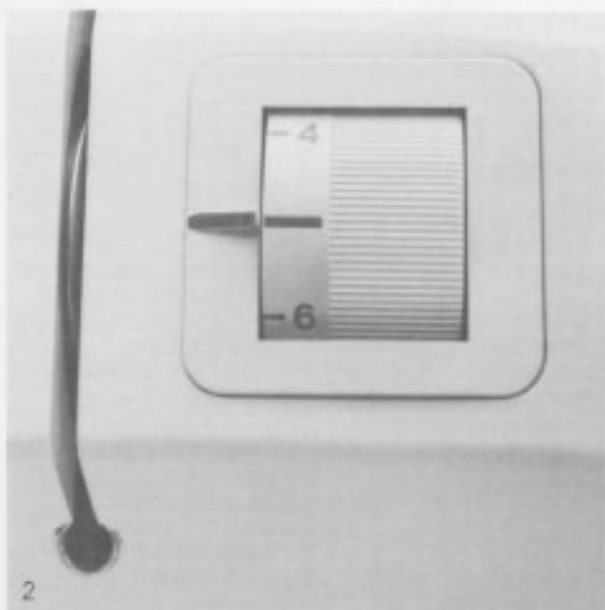

Thread tension



One of the great advantages of BERNINA machines is that the thread tension vary rarely has to be altered for normal sewing. Normal tension is set when the red mark on the regulating dial matches the adjacent mark on the machine (Fig. 2).

Turning the regulating dial forwards, to number 4 or below, gives a looser upper thread tension. Turning the regulating dial backwards, to number 6 or above, gives a tighter upper thread tension.

Do not forget: The thread tension should be reset to normal when special sewing has been completed.



Lowering the feed-dog

For certain types of sewing, eg. for darning, the fabric must not be moved by the feed. Therefore the feed-dog must be lowered, by turning the knob to the left until the mark points to the symbol  (Fig. 3). For all normal sewing, the mark on the knob should point to symbol .

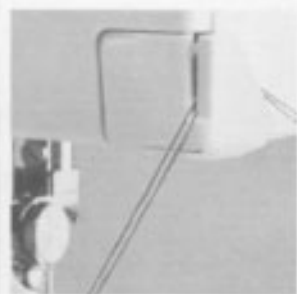

To remove the work, raise the presser foot, pull work out to the rear left and hook both threads into the thread cutter. The thread ends free themselves when you start sewing again.

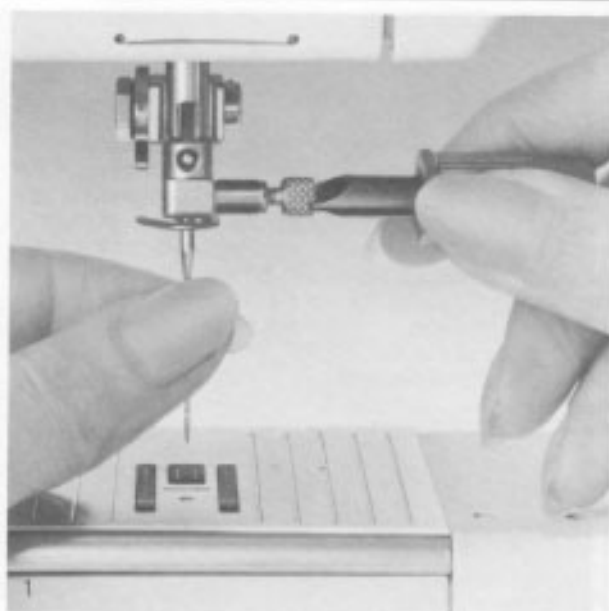

Inserting the needle

A small brown screwdriver for slackening or tightening the needle clamp is provided in the accessories box.

Set the power switch to the  position. Check that the needle is in the raised position.

To slacken the needle clamp: half a turn forwards, anti-clockwise (Fig. 1).

To insert the needle: The flat side of the needle shank should always be to the rear. Insert the needle until it reaches the top. If the needle does not reach the top, i.e. is set too low, skipped stitches will result.

Tighten the needle clamping screw securely.

WARNING:

Please refer to the Safety Instructions.

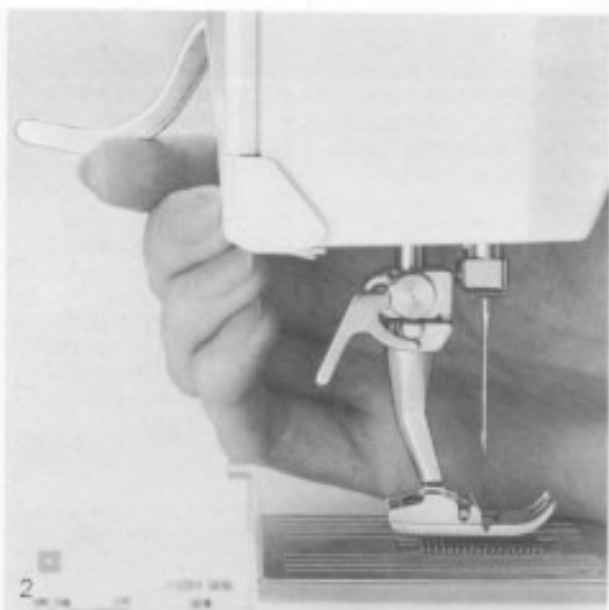

Changing presser feet

For the various presser feet and their uses, see page 13.

The success of a piece of sewing largely depends on the correct choice of presser foot. The presser feet are easy and practical to change.

Set the power switch to the  position.

Check that the needle is in the raised position.

Raise the presser foot (Fig. 2).

Raise the clamping lever with the index finger of the right hand, and using the middle finger and thumb, remove the presser foot (Fig. 3).

To attach the presser foot: The procedure is the same, but press the clamping lever downwards with the index finger (Fig. 4).

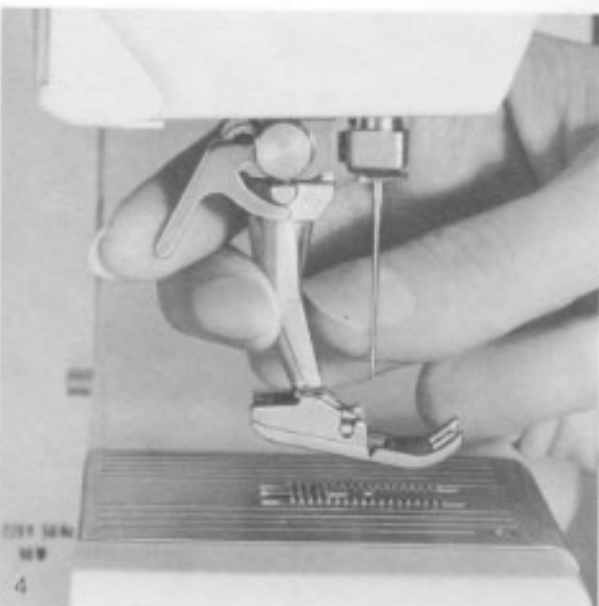
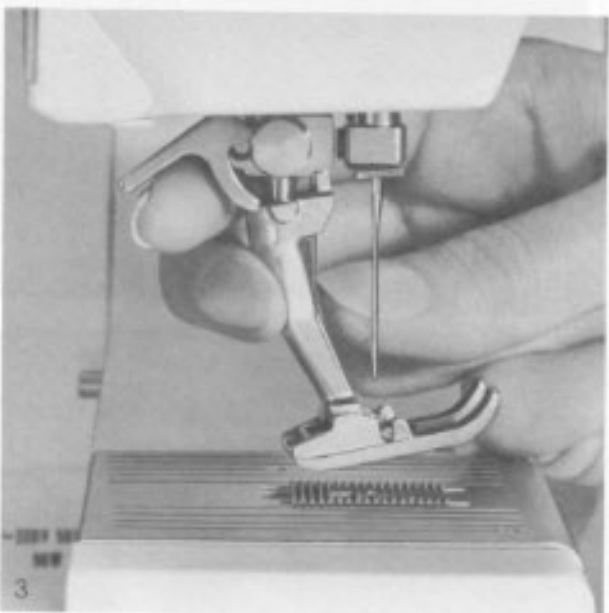

Threads

Needles

Presser feet

Practical stitches

Decorative stitches

Feed-dog and fabric feed

1. Feed-dog and stitch length

With each stitch, the feed-dog moves forward by one stitch. The length of this step is governed by the stitch length selected. With an extremely short stitch length, the steps are extremely short. The fabric moves under the presser foot slowly. For example, buttonholes and satin stitching are sewn with this short stitch length.

Important

a) Make sure that the fabric feeds evenly!



b) Pulling or pushing will result in «gaps».



c) Holding back will result in «pile-ups».



2. Feed-dog and fabric feed

a) The feed-dog can only work effectively if the presser foot is horizontal.



b) If the presser foot is tilted, eg. at a very thick seam or hem, the feed-dog will be unable to grip the fabric. The work will stick.



c) Place a piece of fabric, neatly folded to the thickness of the seam, beside the sewing, so that the presser foot is again level.

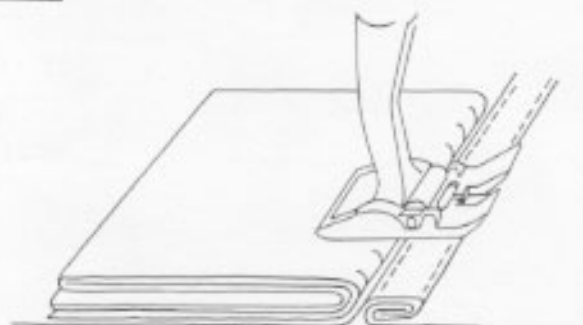

3. Feed-dog and the sewing of corners

a) The two rows of teeth of the feed-dog are quite a distance apart, because of the width of the needle hole.



b) When sewing corners, only a small part of the fabric is on the feed-dog, so it cannot transport the work correctly.

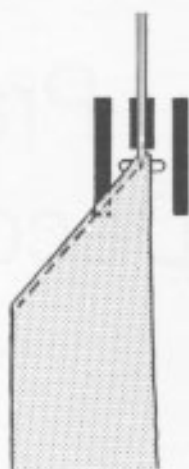

c) If a folded piece of fabric is placed against the corner, the feed-dog will once again be able to work properly.

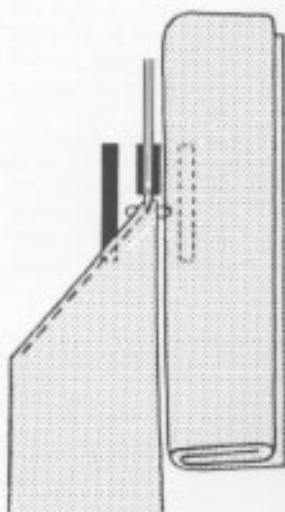

The importance of the sewing machine needle

Needles and the sewing machine

Your BERNINA has a 130/705 H needle system. Make sure, when buying new needles, that they are the 130/705 H system.

Commercially available needle sizes are nos. 70 to 120. The finer the needle, the lower the number. For thread, the opposite applies. The finer the thread, the higher the number.

The table below shows which needle should be used for which thread.

Needles and thread

The needle size required depends on the thread selected. The needle must match the thread.

When sewing, the thread lies in the long groove to the front of the needle (Fig. 1). If the needle is too fine, the thread will not fit into the groove (Fig. 2) and skipped stitches will result.



Needle and fabric Needle condition

The needle must be in perfect condition. Sewing problems are caused by:



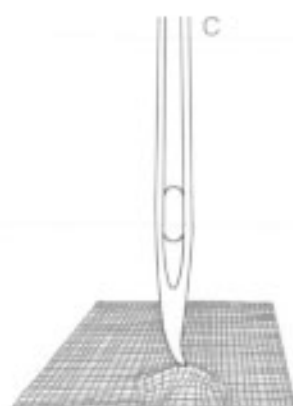
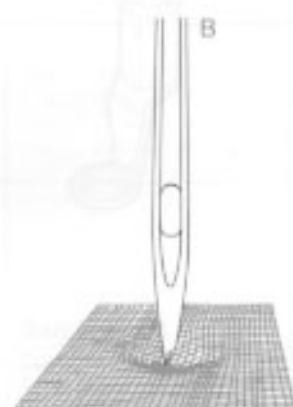

- Bent needles (A)
- Blunt needles (B)
- Hooked tips (C)

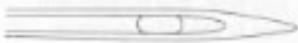
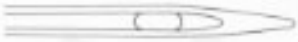

Needle/Thread Table

Needle	70	80	90	100	110-120
Darning/Embroidery thread 60	*	*			
Embroidery thread 30		*			
Mercerised cotton sewing thread		*	*		
Synthetic sewing thread		*	*		
Coarse mercerised cotton Mercerised synthetic			*	*	
Buttonhole thread for top stitching (Cordonnet)				*	*

The modern domestic sewing machine is capable of handling a very wide range of fabrics. However, as with industrial machines, special needles are required for some of these tasks, i.e. needles with varying types of point.

Table of needles	Needle description	Needle point	Suitable for
Standard needles	130/705 H	Normal point, slightly rounded 	Universal needle for woven synthetic and natural fibres, e.g. chiffon, batiste, organdy, linen, wool, velvet, etc.
Special needles	130/705 SES	Fine ball point 	Fine knits in silk, synthetics, cotton and fine wool.
	130/705 H-SUK	Medium ball point 	Heavier knitted fabrics in synthetic or natural fibres.
	130/705 H-Stretch	Medium ball point 	Special stretch needle. Especially for delicate or difficult stretch fabrics.
	130/705 H-J	Extra fine point 	Twill, workwear, heavy linen, denim fabrics, canvas. Penetrates dense fabrics more easily.
	130/705 H-LL or H-LR	Cutting point 	Leather, suede, calfskin, kid, pigskin, imitation leathers and suedes, plastics.

Presser feet

Presser feet are an important aid to sewing. They are designed with grooves and guides. The success of a piece of sewing is determined by the correct choice of presser foot.



Reverse pattern foot

Red practical stitches
Red decorative stitches



Overlock foot

Vari-overlock seam
Vari-overlock hem
Oversewing seam edges



Buttonhole foot

Buttonholes



Zip foot

Sewing in zips
Sewing close along raised seam

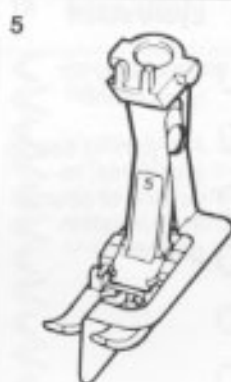













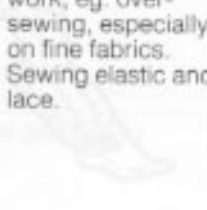



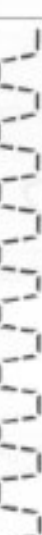

Blind stitch foot

Blind hemming
Edge stitching



Darning foot

Darning
Free hand monograms
Free hand embroidery

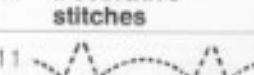
<p>1 Straight stitch</p>  <p>All types of non-elastic fabric</p> <p>All straight stitch work</p> 	<p>2 Zig-zag stitch</p>  <p>For most types of fabric</p> <p>All simple zig-zag work, eg. oversewing, especially on fine fabrics. Sewing elastic and lace.</p> 	<p>3 Sewn-out zig-zag</p>  <p>For most types of fabric</p> <p>Oversewing loosely woven fabrics, reinforcing and repairing edges, decorative work.</p> 	<p>4 Blind stitch</p>  <p>For most types of fabric</p> <p>Blind hemming, shell edging on soft jersey and fine fabrics, decorative work.</p> 
<p>5 Universal stitch</p>  <p>For firmer knitted fabrics, felt leather etc.</p> <p>Flat joining seams, visible hems, patchwork, mending interlock fabrics, sewing on elastic, decorative seams.</p> 	<p>6 Lycra stitch</p>  <p>Especially for lycra fabric</p> <p>Flat joining seams and hems, re-sewing of seams in foundation garments.</p> 	<p>7 Stretch stitch</p>  <p>For highly elastic fabrics</p> <p>Highly elastic open seams for ski, horse-riding, climbing and hiking wear.</p> 	<p>8 Vari-overlock</p>  <p>Primarily for fine synthetic and silk jerseys, helanca and fine cotton and wool jerseys.</p> <p>Elastic overlock seams and hems, particularly suitable for sports underwear, pyjamas, T-shirts, sweat-shirts, jogging suits etc.</p> 
<p>9 Running stitch</p>  <p>For most types of fabric</p> <p>Darning with running stitch, mending of woven fabric, reinforcing edges etc.</p> 	<p>10 Scallop stitch</p>  <p>Primarily for woven fabrics</p> <p>Edging of tablecloths, place mats, collars, cuffs etc.</p> 	<p>11 Decorative stitches</p> 	

12 Triple straight stitch



For corduroy, denim, overall and deckchair fabrics, carpet borders, rucksacks, sleeping bags and similar.

Hard wearing seams for joining pieces of fabric, or top stitching of seams.

13 Triple zig-zag



For denims, corduroys, leathers, decorative hems, light fabrics for blinds and similar.

Visible hems and seams, sewing on tape, extra strong seam for sportswear, woollen blankets, sleeping bags, rucksacks, deckchair fabrics etc.

14 Honeycomb stitch



For many types of jersey and smooth fabrics.

Visible hems and seams for T-shirts, sweatshirts, underwear, place mats, table-cloths, craft work etc.

15 Towelling stitch



Primarily for towelling fabrics, denim, leather and other firmer fabrics.

Flat joining seams, visible hems for beachwear, craft work.

16 Double overlock



For all types of knitted fabrics and hand and machine knitted items.

Overlock seam = Sewing and over-sewing in one operation (hand and machine knitted goods).

17 Jersey stitch



For jersey in natural, blended and synthetic fibres.

Visible hems and seams, particularly in underwear and sweatshirts, mending interlock fabrics, sewing on elastic etc.

18 Edge stitch



For most types of fabric.

Visible hems, sewing on lace and tapes of all kinds, decorative edges, craft work.

19 Reinforced overlock stitch



For sweatshirt material, towelling, medium knits.

Reinforced overlock seams, craft work.

20 Decorative stitches

20 

21 

22 

The pattern indicator

The pattern indicator shows how far a pattern has been sewn.

a) The red mark shows the beginning and end of a pattern.

b) The black mark shows the centre of the pattern.

c) The broken bar (horizontal black marks) warns that the pattern is nearly finished.

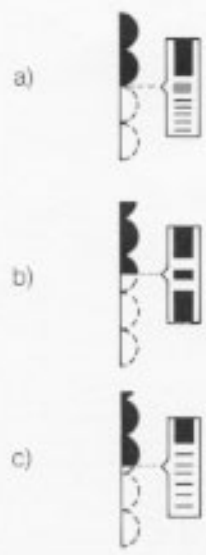

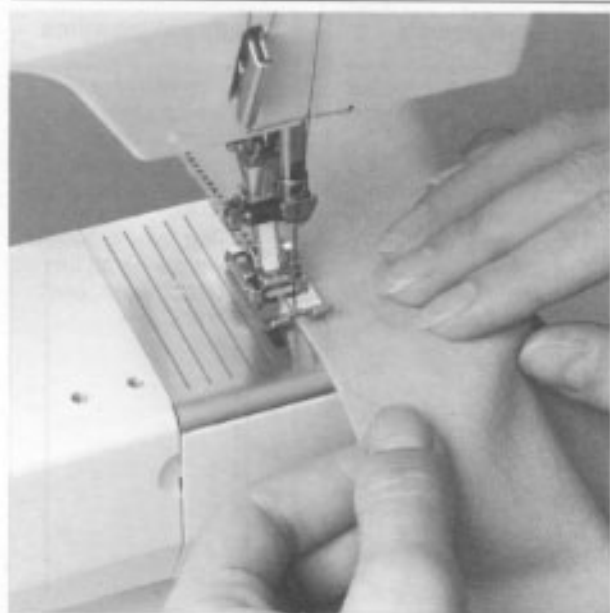

A few hints

Set your Bernina far enough away from the table edge. Correct sitting position and correct guiding of the work will make sewing easier. Sit right in front of the needle, i.e. in front of the working area. This will enable you to watch the working area without strain. Ensure that the height of your chair allows you to work comfortably.

It is best to guide the work from the side with the fingers of the left hand close to the presser foot. When sewing delicate work, it is preferable to stop and guide it a little at a time rather than let the work slide beneath the fingers.

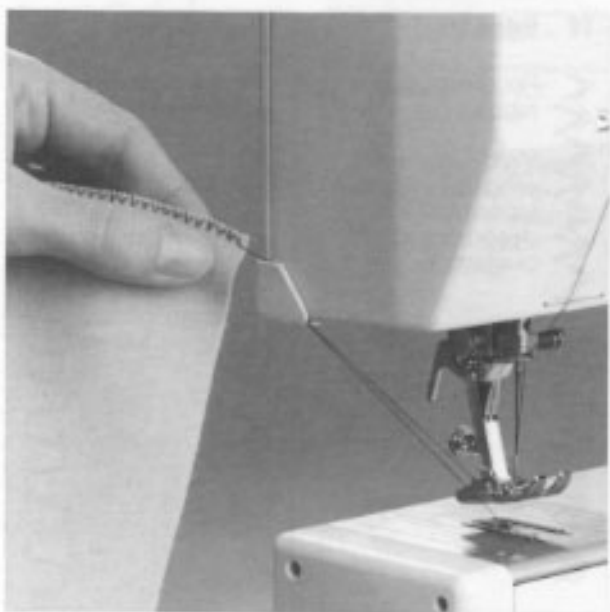

To remove the work, raise the presser foot and check that the needle is raised. If not, turn the handwheel. Take work out to the rear left and hook both threads into the cutter. The thread ends free themselves when you start sewing again.



Practical sewing



Straight stitch Needle position

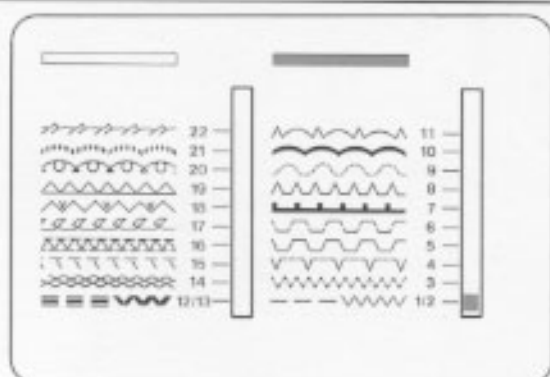

Forward sewing

The machine sews forwards with the settings specified and with the selected stitch length. The stitch length is selected according to the type of sewing and fabric.

Reverse sewing

Push the stitch length knob upwards above 0 and hold until reverse sewing is finished. When the knob is released, the machine will again sew forwards with the previously selected stitch length.

Securing the ends

At the beginning and end of a seam, sew in reverse for approx. 1 cm (3/8") and then forwards again.

Securing thick seams

When changing from forward to reverse sewing and vice versa, stop the machine. The needle stop device always returns the needle to its highest position when the machine stops. This prevents the needle from being bent by thick fabrics.

Presser foot:	1
Thread:	according to fabric
Needle:	according to thread
Stitch:	-----
Stitch width:	0
Stitch length:	1-5 according to fabric
Needle position:	centre
Feed-dog:	sewing
Colour indicator:	-----



Stitch width
Needle position



Buttonhole



Stitch length
Normal stitch length is approx. 2



Colour indicator

Feed-dog

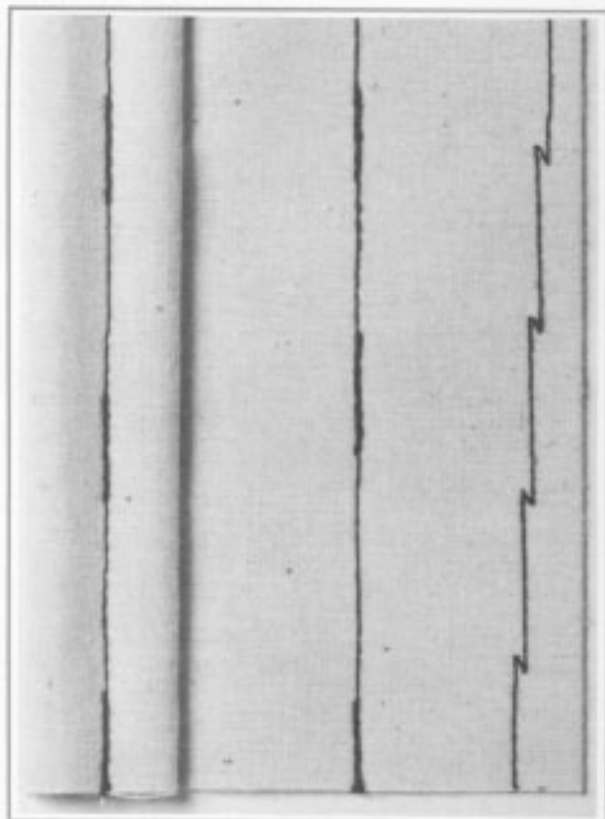

Five needle positions

The position of the stitch can be set to left and right in five positions with the needle position knob.

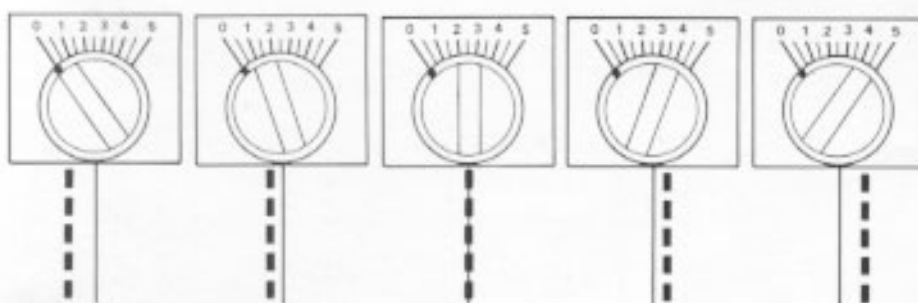



For normal sewing, the needle is in the centre

Examples of use:

Sewing in zips	page 26
Blind hem	page 28
Edge stitching	page 29

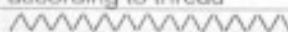
Setting zig-zag

Presser foot:	1
Thread:	according to fabric
Needle:	according to thread
Stitch:	
Stitch width:	1-5
Stitch length:	1-5
Needle position:	centre
Feed-dog:	sewing
Colour indicator:	

Setting zig-zag width and length

The stitch width and length can be altered during sewing or while the machine is stopped.

Set the width of the zig-zag stitch with the stitch width knob. It is completely step-free up to 5 mm. **The needle must not be left in the work when the machine is stopped.**

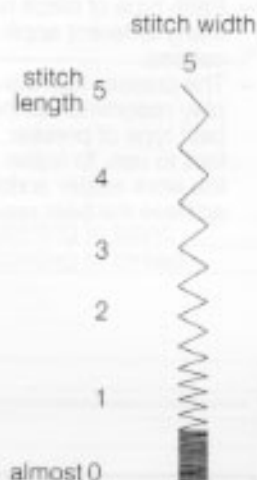

Oversewing edges

Presser foot:	1
Thread:	darning or sewing thread
Needle:	80-70
Stitch width:	2½ - 5 (according to fabric)
Stitch length:	1-3 (according to fabric)

Generally, the zig-zag should not be too wide or the stitch length too long. Start by cutting a neat edge. Use as fine a thread as possible, especially on fine fabrics.

Guide the edge of the fabric to the centre of the foot, so that the needle goes alternately into the fabric and then over the edge (Fig. 1).



Satin stitch = close zig-zag

Presser foot:	1
Thread:	embroidery thread no. 30
Needle:	80
Stitch width:	1½ - 5
Stitch length:	

Set stitch length to very close zig-zag

Turn stitch length knob to the right until it locks.

The mark on the knob is at the top. Stitch length is now 0.

By rotating half a turn to the left (mark at the bottom) the basic setting for satin stitch is obtained. Adjust stitch density from the basic setting according to the work. Turn anti-clockwise for thicker work, clockwise for finer work.

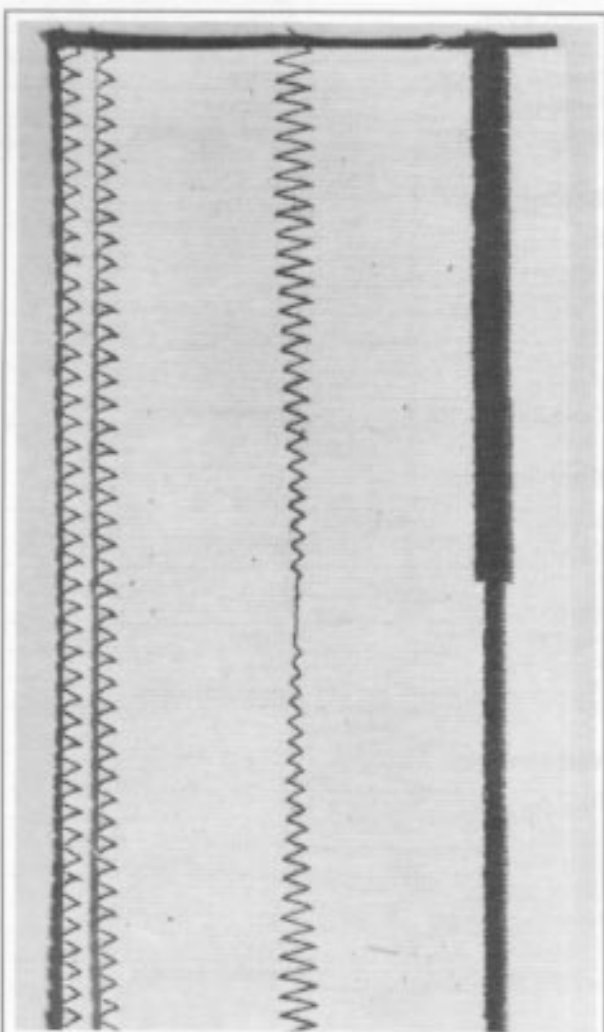

Selecting green stitches

– Push the selector lever to the right to disengage and set to the desired stitch.

– Set the colour indicator to **green**.

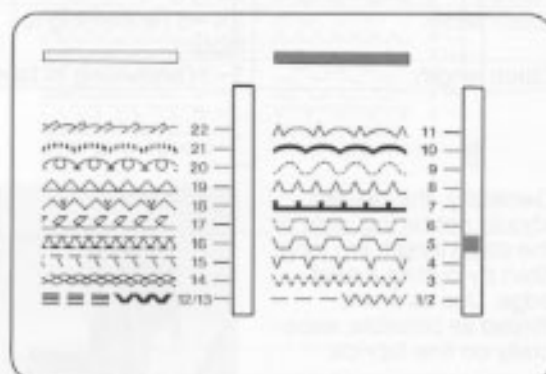

Presser foot
Stitch width
Stitch length
Needle position



Basic setting scale



- As the stitch is selected, the basic setting will be displayed at the same time.
- Each type of stitch has many different applications.
- The presser foot display recommends the best type of presser foot to use, to make the work easier and achieve the best result.

- The stitch width and stitch length can be adjusted to the type of work and to the fabric.



Examples for choosing a stitch

Thread: according to fabric
Needle: according to fabric



Universal stitch

Presser foot: 1
Stitch: 
Stitch width: 4
Stitch length: 1
Needle position: centre
Feed-dog: sewing
Colour indicator: 



Scallop stitch

Presser foot: 1
Stitch: 
Stitch width: 5
Stitch length: approx. 1/4 IIIII
Needle position: centre
Feed-dog: sewing
Colour indicator: 

Running stitch

Presser foot: 1
Stitch: 
Stitch width: 5
Stitch length: 1
Needle position: centre
Feed-dog: sewing
Colour indicator: 

Vari-overlock

Presser foot: 2
Stitch: 
Stitch width: 4
Stitch length: 1
Needle position: right
Feed-dog: sewing
Colour indicator: 

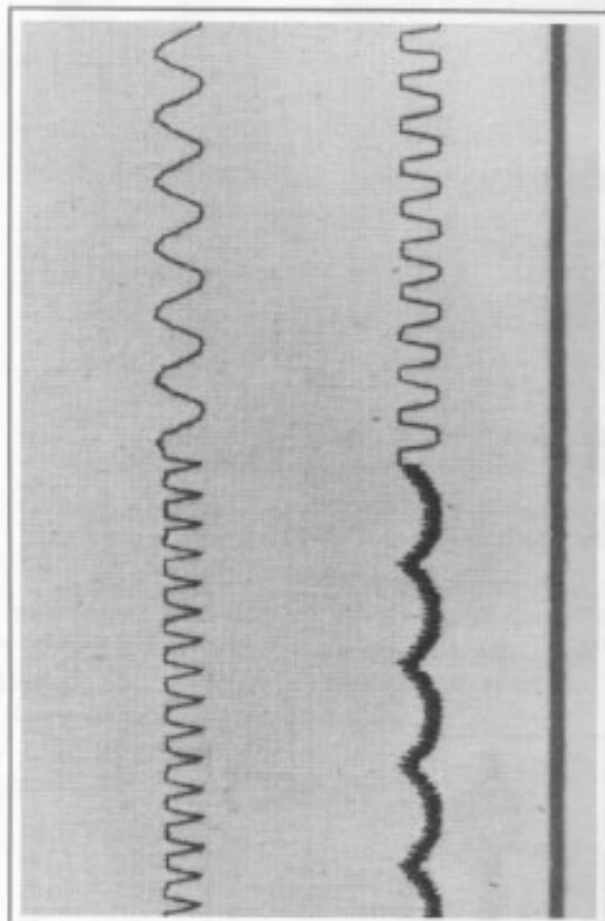

Selecting red stitches

– Push the selector lever to the right to disengage and set to the desired stitch.

– Set the colour indicator to red.

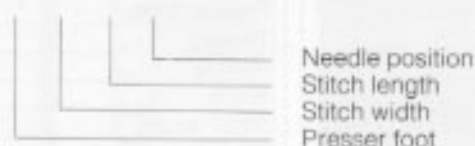
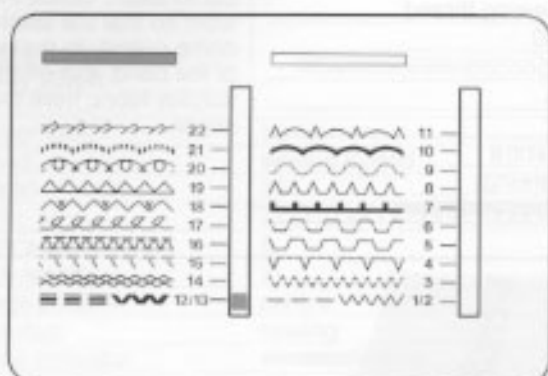

Needle position
Stitch length
Stitch width
Presser foot

Examples for choosing a stitch

Thread:	according to fabric
Needle:	according to thread

Triple straight stitch

Presser foot:	1
Stitch:
Stitch width:	0
Stitch length:	3
Needle position:	centre
Feed-dog:	sewing
Colour indicator:	█

Triple zig-zag

Presser foot:	1
Stitch:	~~~~~
Stitch width:	5
Stitch length:	3
Needle position:	centre
Feed-dog:	sewing
Colour indicator:	█

Jersey stitch

Presser foot:	1
Stitch:	XXXXXX
Stitch width:	5
Stitch length:	2
Needle position:	centre
Feed-dog:	sewing
Colour indicator:	█

Double overlock

Presser foot:	1
Stitch:	XXXXXX
Stitch width:	5
Stitch length:	2
Needle position:	centre
Feed-dog:	sewing
Colour indicator:	█

Basic setting scale

- As the stitch is selected, the basic setting will be displayed at the same time.
- Each type of stitch has many different applications.
- The presser foot display recommends the best type of presser foot to use, to make the work easier and achieve the best result.
- The stitch width and stitch length can be adjusted to the type of work and to the fabric.

Set of stitches with a needle and foot display and a basic setting scale with a needle position indicator.

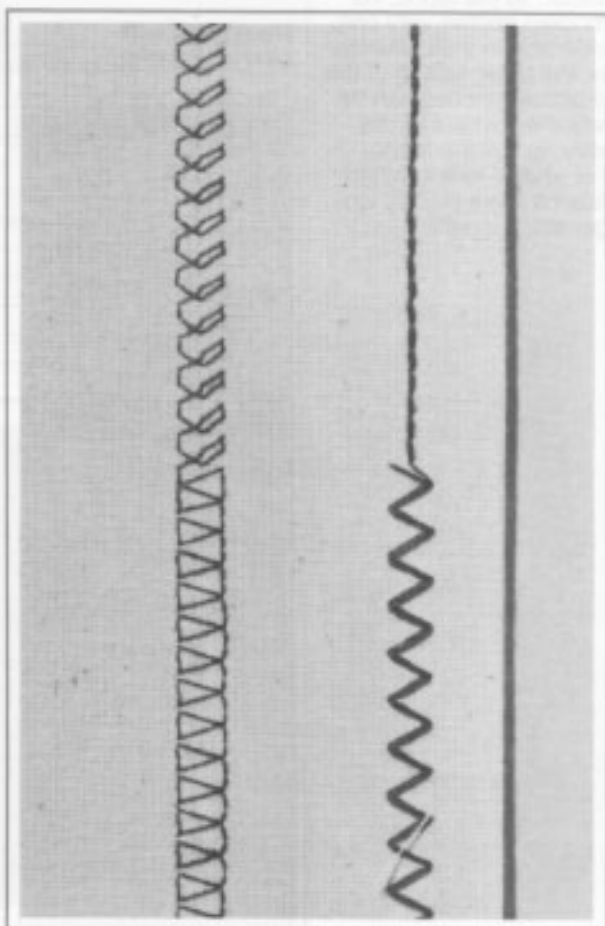

eg. interlock, jersey



When sewing knitted fabrics, the following points generally apply:

1. Use a perfect needle. Even a very slightly blunt needle will damage the knit, causing it to ladder.
2. Use fine sewing thread, particularly for fine jerseys. Coarse thread can also damage the knit.
3. Use darning thread for basting. After the seam has been sewn, darning thread is more easily removed than the considerably thicker and shorter fibre basting thread.
4. Press each seam as it is sewn. This will make subsequent work easier.
5. Sew a sample to test the stretch of the stitch. The seam should be as elastic as the fabric. As modern textiles vary considerably in their elasticity, the basic setting of the practical stitches can be adjusted, where necessary, to suit the fabric. For «hand-look» knitted fabrics use a slightly longer stitch length.

Neckband with visible seam

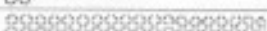

Primarily for knitted cot-

ton fabrics (pyjamas, T-shirts, sports underwear, underwear)

Presser foot:	1
Thread:	sewing thread
Needle:	80
Stitch:	
Stitch width:	5
Stitch length:	2
Needle position:	centre
Feed-dog:	sewing
Colour indicator:	

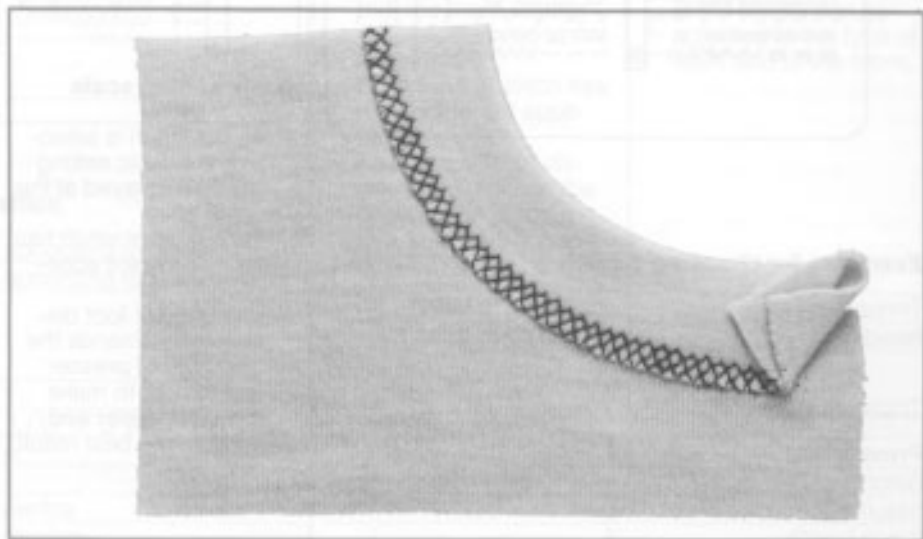
Fold the neatly cut neckband in half and press. Pin and baste to the right side of the neckline. Then sew with Honeycomb stitch. Guide the work so that the stitches come exactly to the edge of the band. Cut off the surplus fabric from the inside.

**Neckband with overlock seam**

Presser foot:	2
Thread:	sewing thread
Needle:	80
Stitch:	
Stitch width:	4-5
Stitch length:	1
Needle position:	right
Feed-dog:	sewing
Colour indicator:	

Fold the neatly cut neckband in half and press. Pin to the right side of the neckline, with the cut edges of the band exactly in line with the neckline edge. When sewing, guide the edges to the pin of the overlock foot.

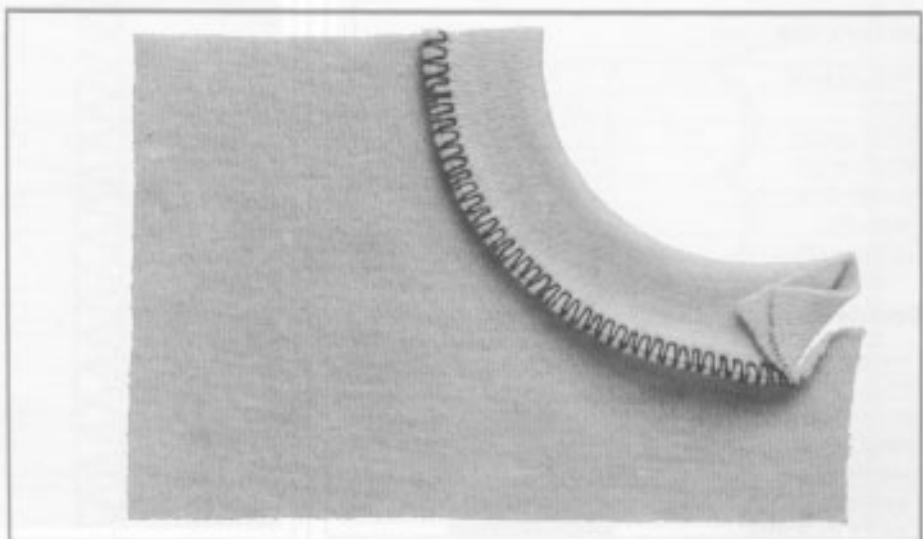

Practical stitch hems

Preparation:

Baste the hem – depth of hem plus 1 cm ($\frac{3}{8}$ "') – mark the desired width – sew and cut off surplus

fabric. When working with knitted fabrics, see general pointers on page 22.

Visible hem with Jersey stitch

Presser foot:	1
Thread:	sewing thread
Needle:	80
Stitch:	
Stitch width:	5
Stitch length:	2
Needle position:	centre
Feed-dog:	sewing
Colour indicator:	

Elastic hem for garments in cotton, fine wool, synthetic and blended fibres, i.e. Pyjamas, T-shirts, underwear and sports underwear.

Pin or baste hem. Sew hem from right side, trim surplus fabric from wrong side.

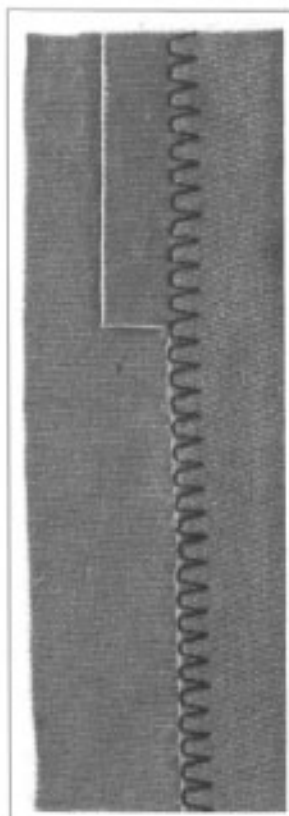
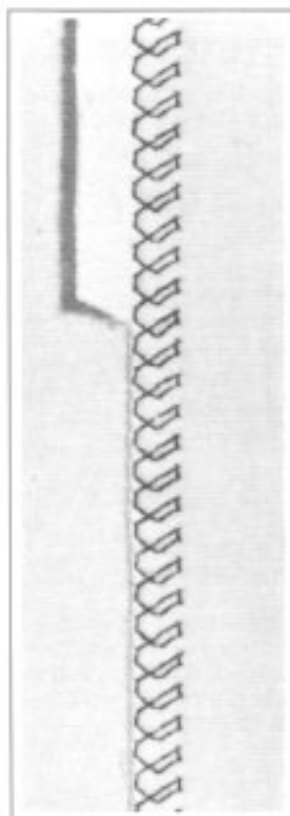

Visible hem with Vari-overlock

Presser foot:	2
Thread:	sewing thread
Needle:	80
Stitch:	
Stitch width:	4
Stitch length:	approx. 1
Needle position:	right
Feed-dog:	sewing
Colour indicator:	

Elastic hem for all jerseys: Stretch towelling, helanca etc.

Pin or baste hem. Sew hem from right side, trim surplus fabric from wrong side.

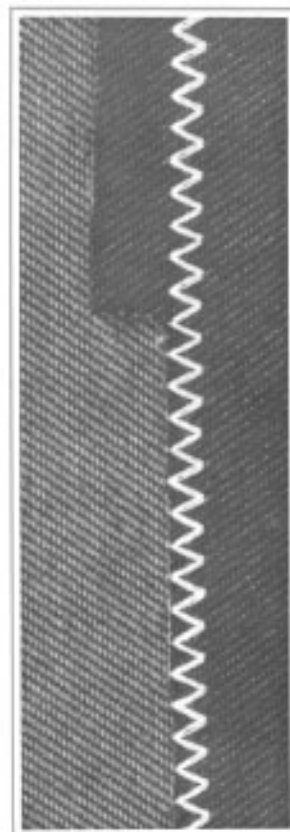

Visible hem with Triple zig-zag

Presser foot:	1
Thread:	sewing thread
Needle:	80
Stitch:	
Stitch width:	2½–5 according to fabric
Stitch length:	2–3
Needle position:	centre
Feed-dog:	sewing
Colour indicator:	

Hard wearing hem for firm fabrics, e.g. Denim etc.

Pin or baste hem. Sew hem from right side, trim surplus fabric from wrong side.

There are three types of seam:

Open seams

These are seams that are pressed open

- they lie flat and are not bulky
- they allow garments to be let out

Overlock seams

These are seams that are sewn and oversewn in one operation

- they are quick to produce
- they are narrow, but do not allow garments to be let out

Flat joining seams

These are seams in which the cut edges are overlapped and then over-sewn

- they lie flat
- they are narrow and cannot be let out
- they do not curl and the edges are neat.

Triple straight stitch seam, open seam

Hard wearing, re-inforced seam for firm fabrics

Especially for Denim and corduroy.

Presser foot:	1
Thread:	sewing thread
Needle:	80–90
Stitch:	*****
Stitch width:	0
Stitch length:	2–3
Needle position:	centre
Feed-dog:	sewing
Colour indicator:	█

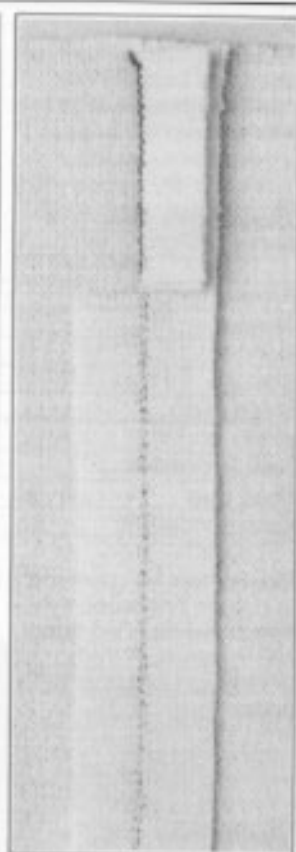

Zig-zag seam

Zig-zag seam, open seam

Elastic seam for jersey fabrics in wool, synthetic or blended fibres, and for silk, cotton and wool interlock.

Suitable for sweaters, jackets and all hand and machine knitted garments.

Presser foot:	1
Thread:	sewing thread
Needle:	80
Stitch:	~ ~ ~ ~ ~
Stitch width:	1
Stitch length:	1½
Needle position:	centre
Feed-dog:	sewing
Colour indicator:	█

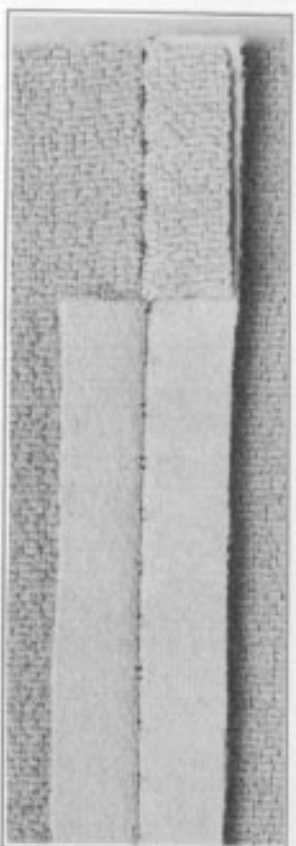

Stretch seam

Stretch seam, open seam

Highly elastic seam for stretch fabrics, especially for sportswear of all kinds.

Suitable also for lounge-wear and craft work.

Presser foot:	1
Thread:	sewing thread
Needle:	80
Stitch:
Stitch width:	1½
Stitch length:	¾–1
Needle position:	centre
Feed-dog:	sewing
Colour indicator:	█

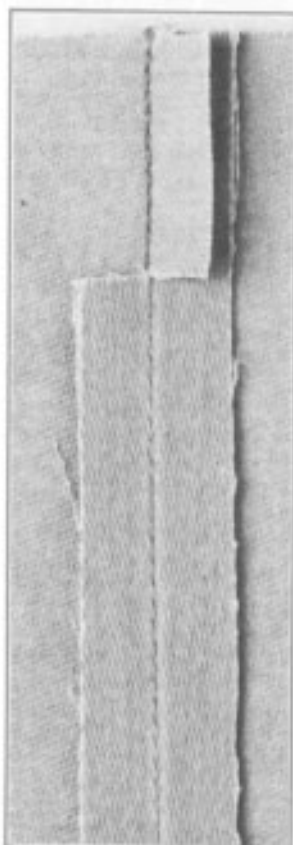

Triple straight stitch seam

Vari-overlock seam

Elastic overlock seam for all fine jersey fabrics, dresses, blouses, underwear, nightwear etc.

Presser foot:	2
Stitch:	
Stitch width:	4
Stitch length:	1
Needle position:	right
Feed-dog:	sewing
Colour indicator:	

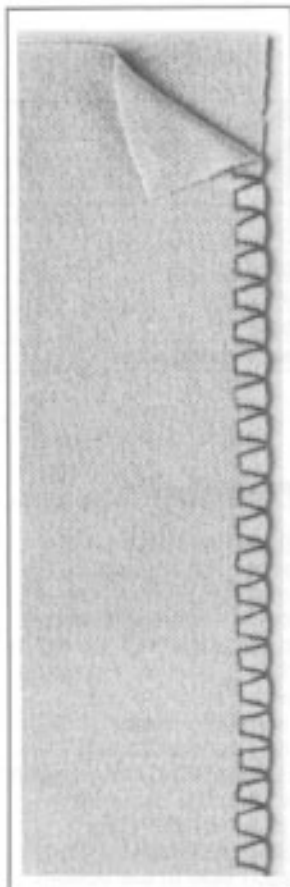

Vari-overlock seam

Double overlock seam

Elastic overlock seam for all thicker or loosely knitted jersey fabrics

Presser foot:	1
Stitch:	
Stitch width:	5
Stitch length:	2
Needle position:	centre
Feed-dog:	sewing
Colour indicator:	

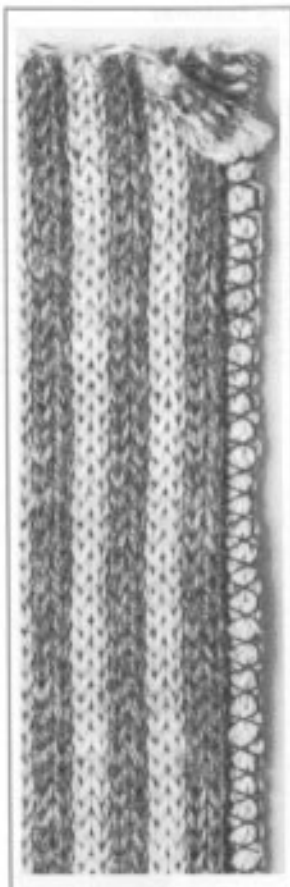

Double overlock seam

Reinforced overlock seam

Elastic overlock seam for sweatshirts, sportswear and casual wear, crafts etc.

Presser foot:	1
Stitch:	
Stitch width:	4-5
Stitch length:	2
Needle position:	centre
Feed-dog:	sewing
Colour indicator:	

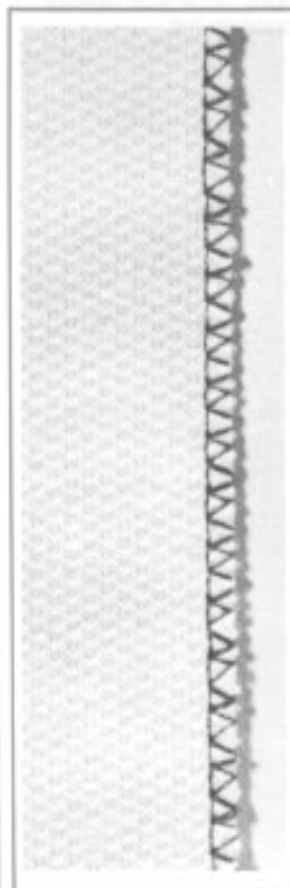

Reinforced overlock seam

Flat seam

Visible seam for towelling, felt, leather, Denim, casual wear, crafts etc.

Presser foot:	1
Stitch:	
Stitch width:	4
Stitch length:	2
Needle position:	centre
Feed-dog:	sewing
Colour indicator:	

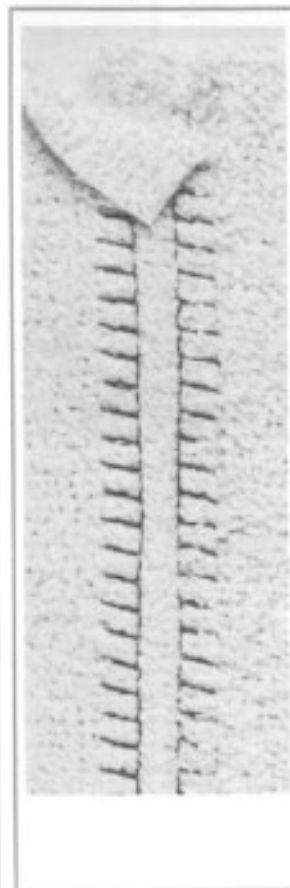

Flat seam

Reminder

For sewing knitted fabrics see page 22.

**Zip fastener,
inserted flat**

Presser foot:	4
Thread:	sewing thread
Needle:	80
Stitch:	-----
Stitch width:	0
Stitch length:	approx. 2
Needle position:	left/right
Feed-dog:	sewing
Colour indicator:	█

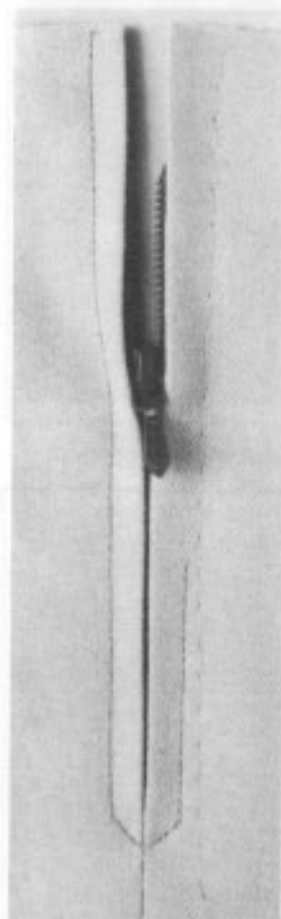
**Preparation:**

Baste entire length of seam. Mark length of zip and sew seam as far as the zip opening. Remove basting stitches, except in the zip section. Press the entire seam, trim and oversew. Remove remaining basting stitches. Baste the zip into position so that the teeth are covered by the fabric. Sew in the zip, starting each side at the bottom and sewing to the top, once with needle position right, once with needle position left.

Plastics

Like synthetic fabrics, plastic is also made from a variety of raw materials. Plastics have to be handled differently when sewn, depending on the surface and grain. If the fabric does not feed properly, it is often sufficient to wipe a little sewing machine oil along the line of the seam (with a small, absorbent cotton wool pad wrapped in fabric).

Otherwise, use one of the special presser feet – Walking foot (No 50), Roller foot (No 51) or Teflon foot (No 52) (Additional accessory). Always sew plastics with a long stitch length to avoid tearing.

**Leather and
imitation leather**



Naturally it is possible to sew leather. Some leathers may require a special leather needle. Sew a test piece before starting on the work itself. Do not choose too short a stitch length. Where necessary, use the Walking foot (No 50), Roller foot (No 51) or Teflon foot (No 52) (Additional accessory).

Sewing with seam/ quilting guide

Insert the seam/quilting guide into the presser foot. The distance between the seam/quilting

guide and the centre of the presser foot corresponds to the space between the rows of sewing.



Presser foot:	5
Thread:	sewing thread/darning thread
Needle:	80-70
Stitch:	
Stitch width:	approx. 3
Stitch length:	2¼
Needle position:	right/half right
Feed-dog:	sewing
Colour indicator:	

Important

As with hand sewing, fine fabrics require a fine needle and fine thread.

Preparation

The hem should be prepared in the same way as for sewing by hand. Oversew raw edge, baste and press.

Positioning the hem

The hem is positioned under the foot as shown in (Fig. 1).

Sewing test

(Either on a remnant of fabric or directly on the hem).

Given the variations in fabric thicknesses, it is advisable to sew a test piece first. As when sewing by hand, the needle should only catch the fold of the fabric.

Because of these variations, a slight adjustment may be necessary. Set the needle position to right or half right. Sew slowly, until the needle swings to the left. Using the handwheel, bring the needle down until it is just about to enter the fabric, and check that it is only just catching the fabric. If necessary, adjust the stitch width slightly:

Narrower if the needle is going in too far and a little wider if it is failing to catch sufficiently. Check the next zig-zag stitch in the same way. Then sew for approximately 10 cm (4") and check again.

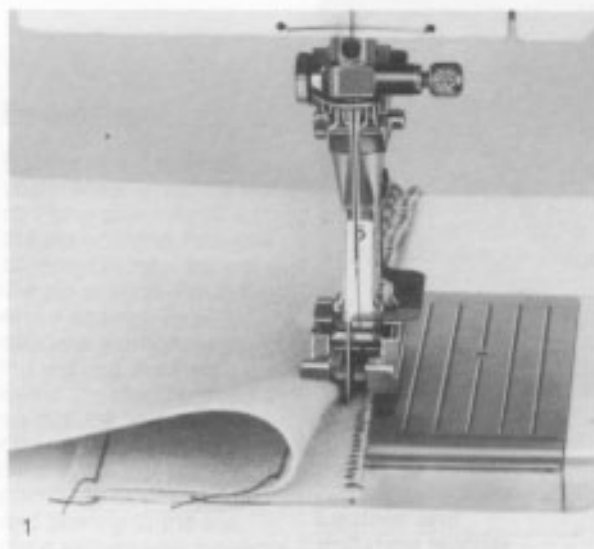

Fig. 1. Blind hemming.

Fig. 2. Guiding the work.

Fig. 3. Guiding the work.

Fig. 4. Guiding the work.

Fig. 5. Guiding the work.

Fig. 6. Guiding the work.

Fig. 7. Guiding the work.

Fig. 8. Guiding the work.

Fig. 9. Guiding the work.

Fig. 10. Guiding the work.

Fig. 11. Guiding the work.

Fig. 12. Guiding the work.

Fig. 13. Guiding the work.

Fig. 14. Guiding the work.

Fig. 15. Guiding the work.

Fig. 16. Guiding the work.

Fig. 17. Guiding the work.

Fig. 18. Guiding the work.

Fig. 19. Guiding the work.

Fig. 20. Guiding the work.

Fig. 21. Guiding the work.

Fig. 22. Guiding the work.

Fig. 23. Guiding the work.

Fig. 24. Guiding the work.

Fig. 25. Guiding the work.

Fig. 26. Guiding the work.

Fig. 27. Guiding the work.

Fig. 28. Guiding the work.

Fig. 29. Guiding the work.

Fig. 30. Guiding the work.

Fig. 31. Guiding the work.

Fig. 32. Guiding the work.

Fig. 33. Guiding the work.

Fig. 34. Guiding the work.

Fig. 35. Guiding the work.

Fig. 36. Guiding the work.

Fig. 37. Guiding the work.

Fig. 38. Guiding the work.

Fig. 39. Guiding the work.

Fig. 40. Guiding the work.

Fig. 41. Guiding the work.

Fig. 42. Guiding the work.

Fig. 43. Guiding the work.

Fig. 44. Guiding the work.

Fig. 45. Guiding the work.

Fig. 46. Guiding the work.

Fig. 47. Guiding the work.

Fig. 48. Guiding the work.

Fig. 49. Guiding the work.

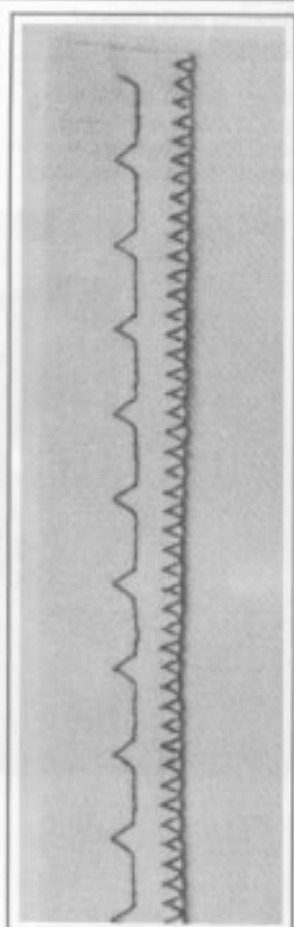

Guiding the work
In this way you can check that the hem is running straight. Tip: While sewing, hold the under fabric back slightly (Fig. 2).

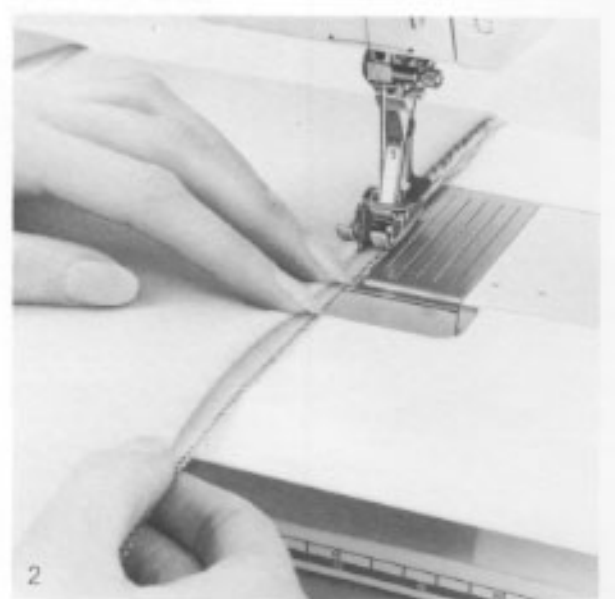

Edge stitching on collars, cuffs, lapels, hems etc.

Presser foot:	5
Thread:	sewing thread
Needle:	80
Stitch:	-----
Stitch width:	0
Stitch length:	2-5 as required
Needle position:	left / half left
Feed-dog:	sewing
Colour indicator:	█

Top stitching, for edges of all kinds

Presser foot:	1
Thread:	sewing thread
Needle:	80
Stitch:	-----
Stitch width:	0
Stitch length:	2-5 as required
Needle position:	any position
Feed-dog:	sewing
Colour indicator:	█

Place the edge of the fabric from the left against the guide of the Blind stitch foot (Fig. 1). Set the

needle position to left or half left.

Guide the edge of the fabric to the edge of the presser foot or along the marks in the stitch plate.



Widths:

(Needle position: centre)

Edge of presser foot = 7.5 mm ($\frac{3}{16}$ ") (Fig. 2)

Marks in stitch plate

Line 1 = 1 cm ($\frac{3}{8}$ ")

Line 2 = 1.5 cm ($\frac{5}{16}$ ")

Line 3 = 2 cm ($\frac{3}{4}$ ")

Line 4 = 2.5 cm (1") (Fig. 3)

Line 5 = 3 cm ($1\frac{1}{8}$ ")

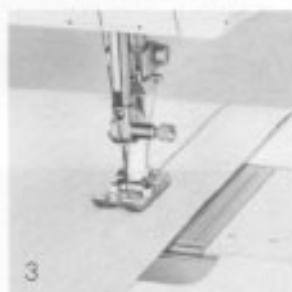
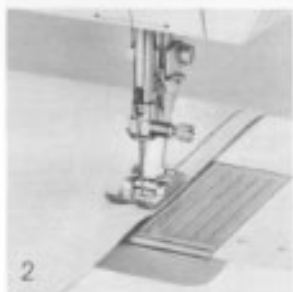
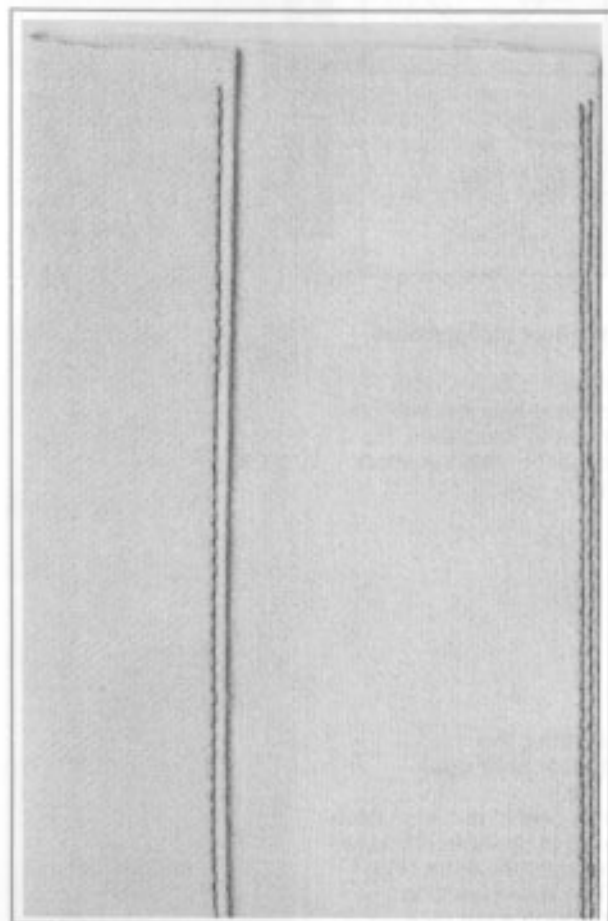

It is also possible to sew intermediate widths using the left, half left, right and half right needle positions.

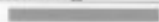
Presser foot:	3
Thread:	sewing thread/darning thread
Needle:	80-70
Stitch:	
Stitch width:	set automatically
Stitch length:	
Needle position:	set automatically
Feed-dog:	sewing
Colour indicator:	

To sew buttonholes, thread the lower thread through the finger of the bobbin case (Fig. 1).

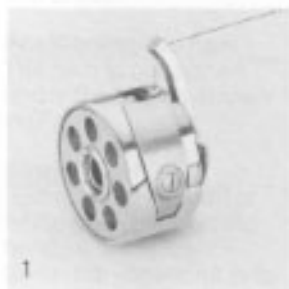

Setting buttonhole

1. Switch buttonhole knob to position 1 (Fig. 2).



2

2. Set stitch length: Turn knob to the right until it locks. The mark will be at the top (Fig. 3). Stitch length is 0. By rotating half a turn to the left (mark at the bottom)



3

the basic stitch length setting for buttonhole is obtained.

Set the stitch density according to the fabric. Turn anti-clockwise for thicker fabrics, clockwise for finer fabrics. Always sew a trial buttonhole. The stitch length will vary slightly depending on the fabric.

Sewing the buttonhole

Lower the needle with the aid of the handwheel and check that it is in the **centre** of the presser foot. If not, do one stitch by turning the handwheel.

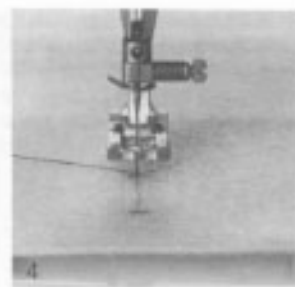

Lay the fabric under the foot, so that the edge of the fabric lies in front of the presser foot (Fig. 4). Lower the needle into the fabric precisely at the start of the buttonhole. Lower the presser foot and sew the buttonhole.

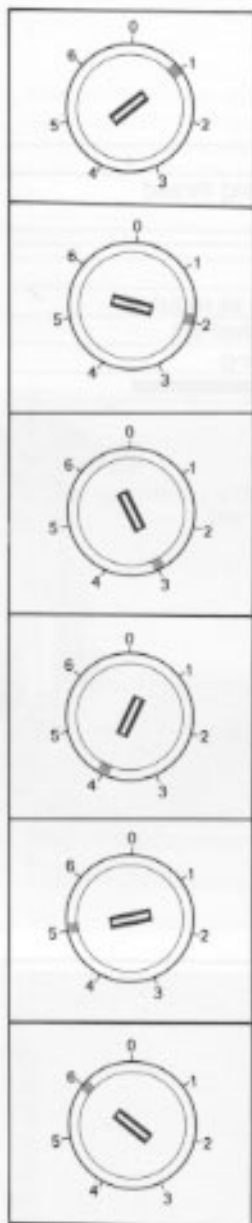

Knob to 1
The machine sews the first bead forwards.

Knob to 2
The machine sews a reverse straight stitch.

Knob to 3
The machine sews the bar tack.

Knob to 4
The machine sews the 2nd bead forwards.

Knob to 5
The machine sews the bar tack.

Knob to 6
The machine sews the securing stitch.

Further buttonholes

Reset button 1. The sewing sequence continues as described. For all other sewing, set knob to 0.

Cutting the buttonhole open

It is best to cut from each end of the buttonhole towards the centre (Fig. 5). This avoids cutting through a bar tack.



Buttonhole with gimp cord

The gimp cord strengthens the buttonhole

The gimp cord is especially important for all knitted fabrics – including hand and machine knits – to prevent the buttonhole from pulling out of shape.

The thickness of the cord depends on the fabric to be sewn. Suitable cords are: perle cord no. 8, thick hand sewing thread or fine crochet cord. Sew a trial buttonhole.

Lower the needle with the aid of the handwheel and check that it is in the centre of the presser foot. If not, do one stitch by tapping the foot control once. Lay the fabric under the foot, so that the folded edge or seam lies in front of the presser foot. The loop of the gimp will lie at the end of the buttonhole where the button will pull (Fig. 2).

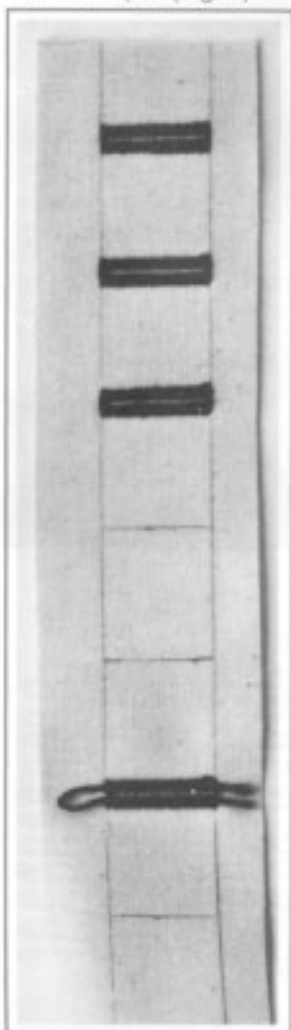

Sewing with gimp cord

It is easier to position the cord if the needle is already in the fabric: Lower the needle into the fabric precisely at the start of the buttonhole. Do not lower the foot yet (Fig. 1).

Hook the gimp cord over the centre prong of the buttonhole foot and take both ends back under the foot (Fig. 2). Lower the foot and check that the cord is able to slide, i.e. is not trapped by the foot.

Sew the buttonhole. At position 2 («reverse straight stitch»), the cord comes away from the prong of the foot. Therefore it is advisable to hold the loop of gimp down LIGHTLY with the finger (Fig. 3).

Finally, pull the loop of gimp through. With knitted fabrics, pull the gimp ends to the rear with a coarse hand sewing needle (Fig. 4) and tie or sew in securely. In woven fabrics, the gimp ends can be simply cut off.

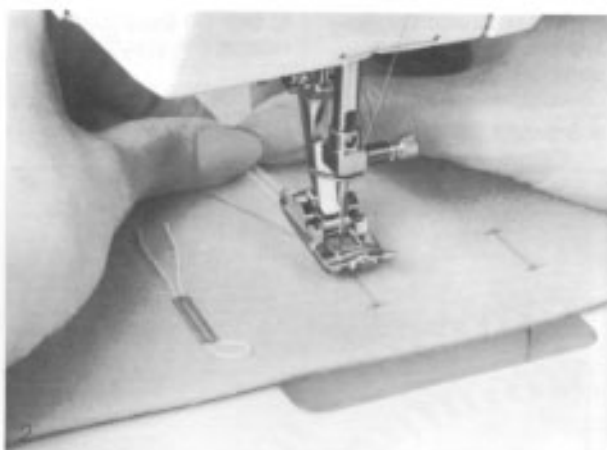
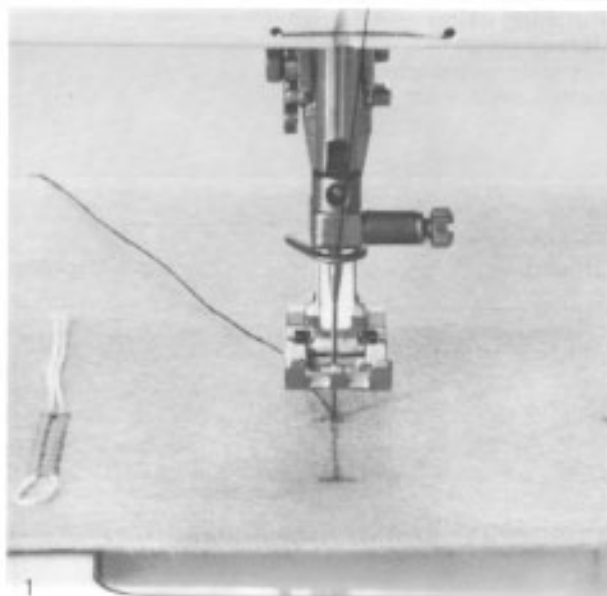

Patching using Jersey stitch

Primarily for mending interlock underwear

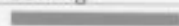
Presser foot:	1
Thread:	darning thread / Machine emb. 60
Needle:	80-70
Stitch:	
Stitch width:	5
Stitch length:	2
Needle position:	centre
Feed-dog:	sewing
Colour indicator:	

Small tears / worn areas are best darned. See page 34. For larger tears or worn areas, it is better

to sew on a patch, as this retains the elasticity.

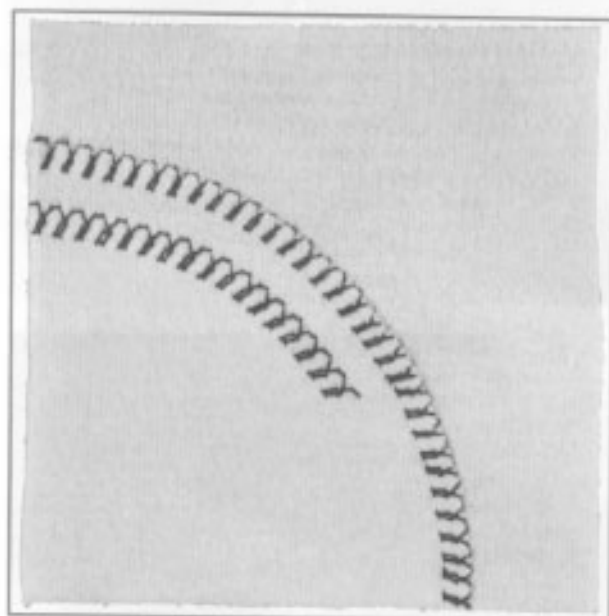



Cut out a patch, if possible from the sound part of a discarded similar garment. Where possible, round off the corners to preserve the elasticity in all directions. Pin on the patch and baste. Then sew with 1-2 rows of Jersey stitch. Finally, cut away torn/worn piece from behind patch.

For all knits, refer to the general pointers for «Sewing knitted fabrics», page 22.

Edging with shirring elastic

The shirring elastic is used to restore distorted edges to their original shape (to save bands being replaced).

Presser foot:	1
Thread:	darning thread / Machine emb. 60
Needle:	80
Stitch:	
Stitch width:	4-5
Stitch length:	1 1/2
Needle position:	centre
Feed-dog:	sewing
Colour indicator:	

Guide two strands of shirring elastic along the edge and oversew with zig-zag stitches, gently

pulling the elastic thread (Fig. 1).

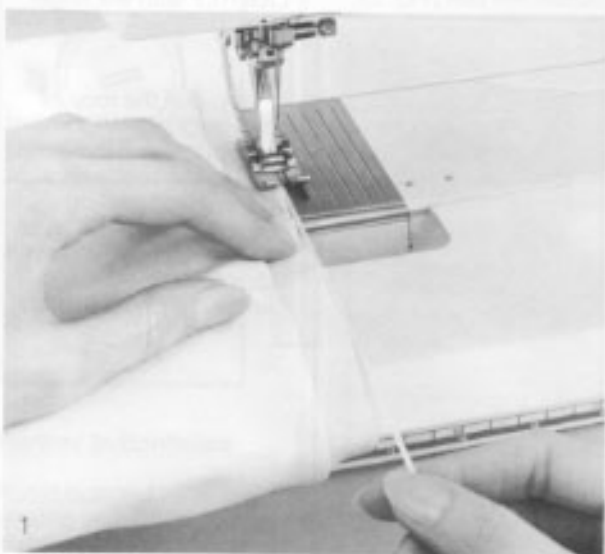



Mending woven fabric

Mending tears using

Running stitch

(Modern darning method)
for tears and thin areas
on virtually all fabrics.

Presser foot:	1
Thread:	darning thread / Machine emb. 60
Needle:	80
Stitch:	
Stitch width:	5
Stitch length:	lllll
Needle position:	centre
Feed-dog:	sewing
Colour indicator:	

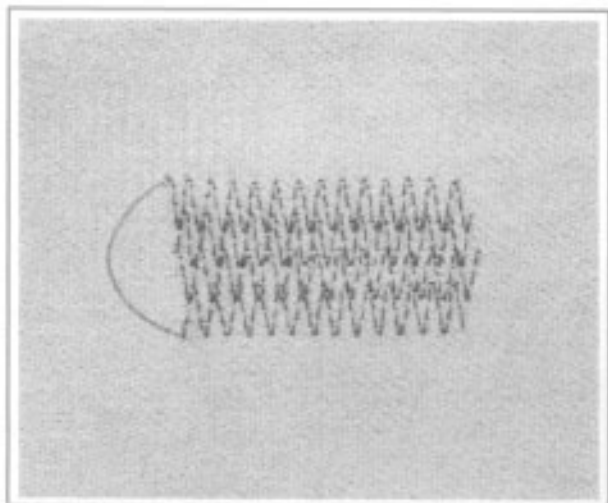

Always lay a fine fabric underneath. On tears, sew 3–5 rows of Running stitch, depending on the type of fabric (Fig. 1). On thin areas, sew sufficient adjacent rows to cover. Let each row overlap the previous one very slightly.

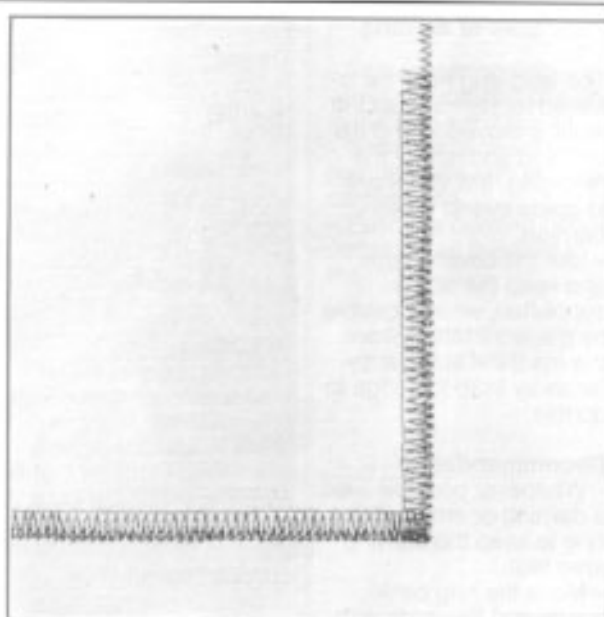
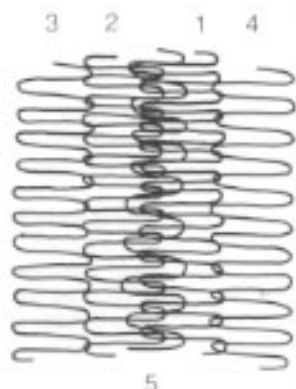

Patching with Running stitch

for overalls and children's
jeans

Presser foot:	1
Thread:	darning thread / Machine emb. 60
Needle:	80
Needle position:	centre
Feed-dog:	sewing

1st step

Stitch:	
Stitch width:	2
Stitch length:	approx. 1
Colour indicator:	

Do not cut out damaged
areas. Pin patch to the
right side and sew along
edge with a small zig-zag
stitch.

2nd step

Stitch:	
Stitch width:	5
Stitch length:	approx. ¼ llll
Colour indicator:	

Oversew edges with
Running stitch. Ensure
that the whole of the
Running stitch is on the
patch, and that the need-
le, on its right swing just
goes to the edge of the
patch.

3rd step

Stitch:	-----
Stitch width:	0
Stitch length:	approx. ¼
Colour indicator:	

Sew a straight stitch on
the inside edge of the
Running stitch. The line
of straight stitches will
make it easier to cut away
the worn area.

Principles of darning

The feed-dog must be lowered for darning, as the work is moved to and fro by hand and not by the feed-dog. It is important to guide evenly when darning.

– Use the sewing table and keep the elbows supported, when possible by the work table. Move the machine sufficiently far away from the edge to do this.

Recommendation

– Whenever possible, use a darning or embroidery ring to keep the darning area taut.

– Move the ring backwards and forwards without pressure, otherwise jerky movements and thread breakage will result.

– Always work from left to right, moving up and down over the hole. Do not move the hoop from side to side.

– The ideal way to hold the ring is with the little fingers and thumbs to the outside of the ring, held firmly to give a smooth movement.

Presser foot:	9
Thread:	darning thread / Machine emb. 60
Needle:	80–70
Stitch:	-----
Stitch width:	0
Stitch length:	0
Needle position:	centre
Feed-dog:	lowered
Colour indicator:	█

Important

Darn in a curved rather than a pointed shape, otherwise the fabric is liable to tear. Beginners often tend to prefer L and M movements, but care must be taken to ensure that this does not result in circular movements.

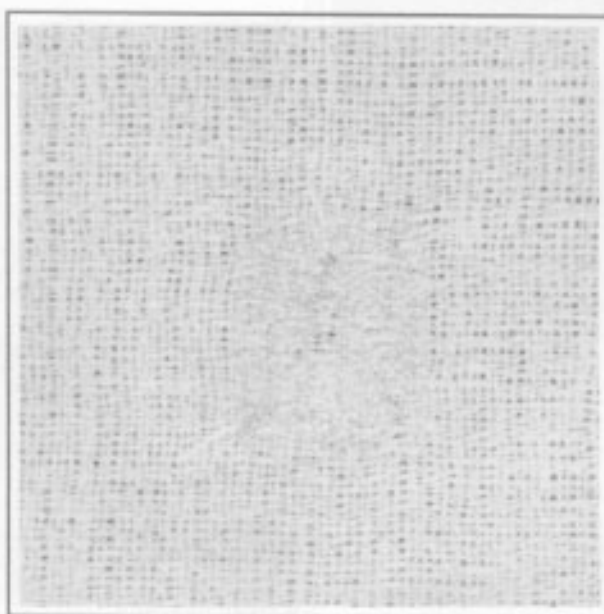
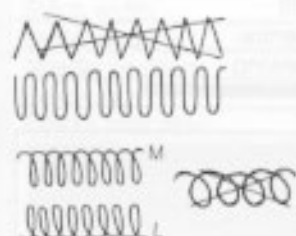
**Darning technique**

There are various methods of darning. Here is a method that is easy to learn:

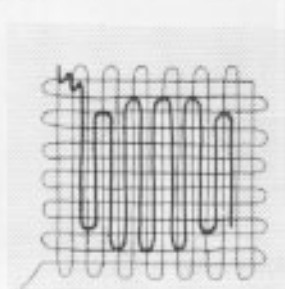
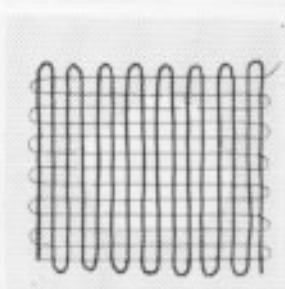
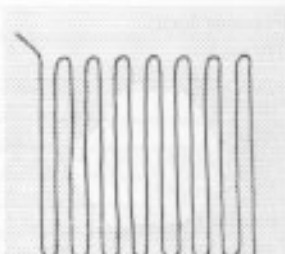
**The three steps**

1. Bring lower thread up, start at top left, work from left to right across hole, finish at top right, then turn through 90°.

2. Again work from left to right, but not too densely that a ridge forms at the edge. Turn work through 180°.

3. Fill in the darn, but only across the «hole». The stitches will be in the same direction so that they blend with the 2nd row.

When the darning technique has been mastered, work the rows of stitches in irregular lengths so the darn blends into the fabric.

Main faults

Thread frequently breaks:

– Fabric is guided unevenly.

Stitching is unattractive, thread lies loose on top:

– Fabric is guided too quickly.

Small knots form on the underside:

– Fabric is guided too slowly.

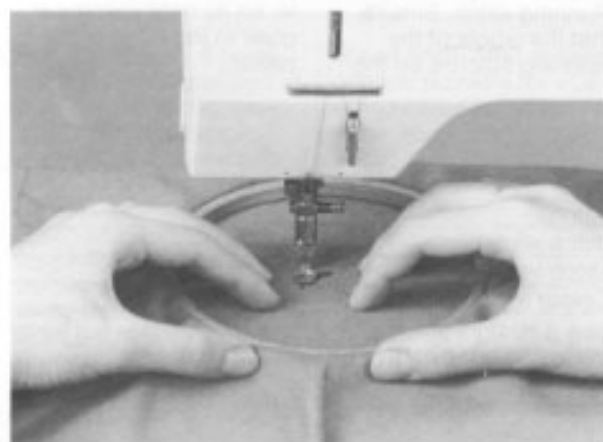

Darning with small darning ring

The small darning ring

The small darning ring is particularly practical for darning small torn/worn areas in fine fabrics and in fine underwear of all kinds, fine socks and pullovers, eg. in Helanca, interlock, jersey.

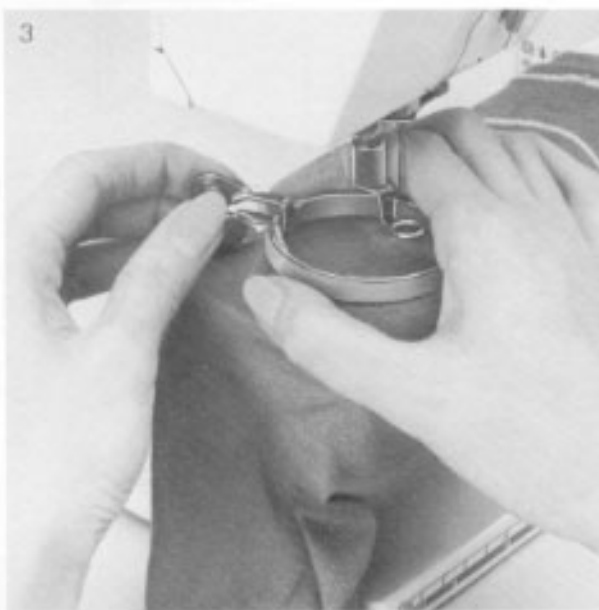

Stretching the work

– Fit the darning ring without the spring clip on to the free arm (Fig. 1).
– Slide the garment over both the free arm and the darning ring.
– Push the darning ring out as far as possible to the left.

– Place the index finger and thumb of the right hand on the darning ring to form a circle.
– With the left hand, stretch the fabric over the end of the free arm. Hold the tensioned fabric with the thumb of the right hand (Fig. 2).

– With the left hand, fit the spring clip as follows: Close the spring clip, insert under the index finger of the right hand and hold firmly. Then press the spring clip into the darning ring (Fig. 3).

Darning technique

Tubular items are usually stitched up and down and then side to side as it is not possible to turn the work.

The ruler/template is extremely versatile and simple. Using the red slide, the required size can be set with millimetre accuracy.

There are two ways of using the template:

a) Using the edges, when lines are required.

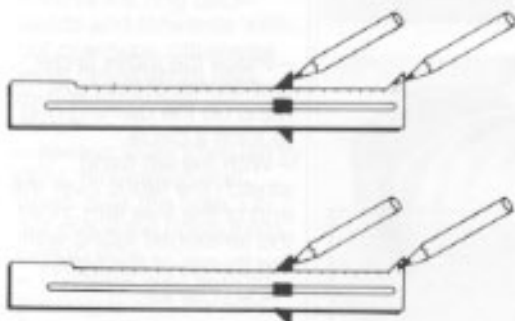

b) Using the small holes when dots are required.

Examples

1. Marking at intervals

For buttonholes, buttons, eyelets, pleats etc.

Set the desired space with the red slide. Transfer dots or lines to the work.

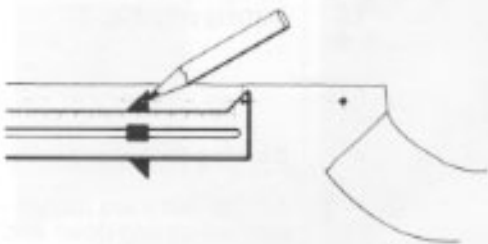

2. Calculation of buttonhole lengths

Flat buttons
Button + 2–3 mm ($\frac{1}{8}$ ")

Domed buttons (or thick fancy buttons)
Button + 5–8 mm ($\frac{1}{4}$ " – $\frac{3}{16}$ ")



3. Marking of buttonholes

Transfer buttonhole length to the garment.

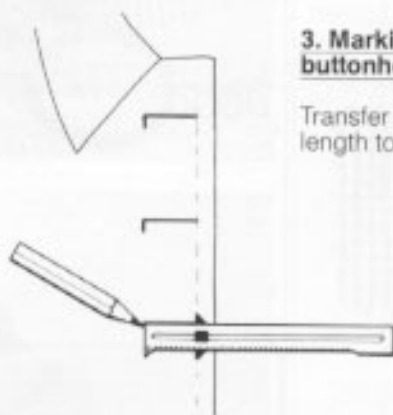

4. Marking of hem depths

Set the desired hem depth with the red slide. Place the red slide against the hem edge. Mark the hem depth.



5. Marking sewing lines

Set the desired width with the red slide. Place the red slide against the edge of fabric or to seam. Mark the sewing line.

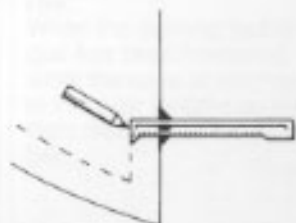
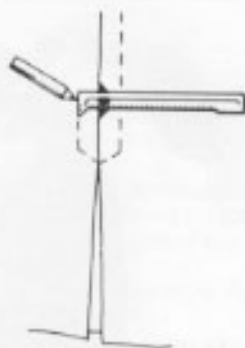

Fault prevention

If the sewing machine does not sew properly, it is usually due to incorrect operation.

Check whether:

- The upper and lower threads are correctly threaded.
- The needle has been correctly inserted, with the flat side of the shank to the rear.
- The needle size is correct. See needle and thread table.
- The machine is clean. Brush out any remnants of thread.
- The hook race is clean and oiled.
- Any remnants of thread are trapped between the thread tensioning discs and beneath the bobbin case spring.

Upper thread breaks

- The upper thread tension is too tight.
- Poor quality needles. Ideally, needles should be purchased from a BERNINA dealer.
- The needle has been fitted incorrectly. The flat side of the shank must be to the rear.
- The needle is blunt or bent.
- Poor quality thread, knotted or dried out thread.
- Stitch plate or hook tip damaged. Take to a BERNINA dealer.

Lower thread breaks

- The lower thread tension is too tight.
- The bobbin is jamming in the bobbin case. Replace bobbin.
- The hole in the stitch plate has been damaged by the needle. This must be re-polished by an expert.
- The needle is blunt or bent.

Skipped stitches

- Wrong needles. Use only 130/705 H needle system.
- The needle is blunt, bent or incorrectly fitted. Push right to the top when inserting.
- Poor quality, badly polished needle.
- The needle point does not suit the fabric being sewn. If necessary, use ball point for knitted fabrics and cutting point for hard leather.

Needle breaks

- Needle clamping screw not sufficiently tightened.
- Fabric withdrawn forwards instead of backwards under the presser foot.
- When sewing over a thick area, the fabric was pushed while still in the fabric.
- Poor quality thread, unevenly wound or knotted.

Faulty tension

- Remnants of thread between the thread tensioning discs.
- Remnants of thread under the bobbin case spring.
- Lower thread still threaded in the bobbin case finger.
- Threaded with foot down.
- Incorrectly threaded. Check lower and upper threads.

Machine fails to run, or will run only slowly

- Plug is not properly inserted.
- Power switch in position.
- Machine gummed up by unsuitable oil. Machine will have to be cleaned by a BERNINA dealer.
- Machine has been standing in a cold room.

Important

If you have to take your machine to a BERNINA dealer, please always take the foot control unit and accessories.



Sewing light:
220V/15 Watt

WARNING:

Please refer to the
Safety Instructions.

Changing the bulb

Disconnect the machine from the mains – take the plug out of socket. Using the special bulb holder, press the bulb up, twist to the left and remove.



To insert new bulb:
Place the new bulb on the bulb holder. Insert the bulb into the socket, press upwards and twist to the right as far as it will go.

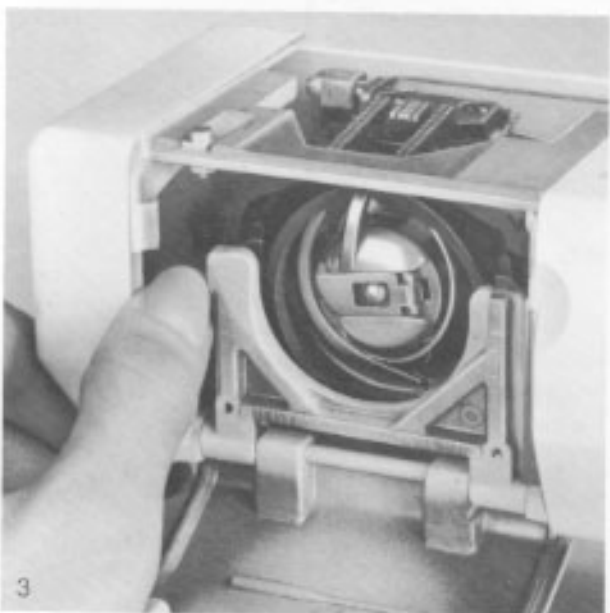
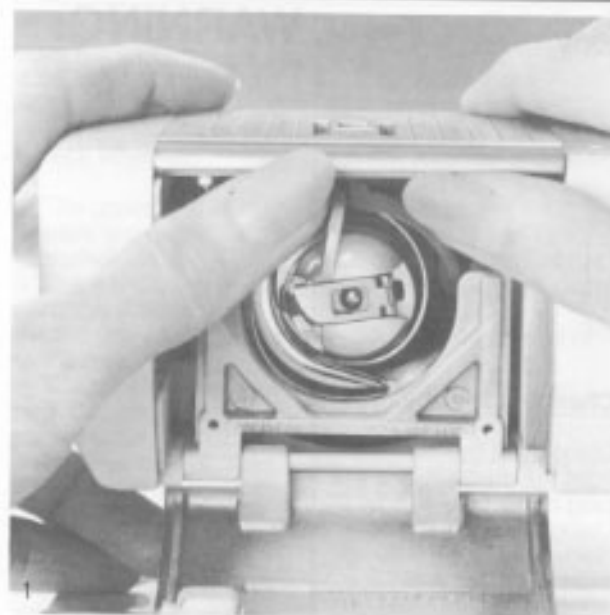

If the machine is stored in a cold room, it should be brought to a warm room approximately one hour before use, to restore the oil in the bearings to a fluid state.

Cleaning

During sewing, fluff from the thread will collect under the stitch plate and around the hook. These remnants must be removed from time to time.

- Disconnect the machine from the mains by pulling the mains plug from the socket.
- Remove the presser foot and needle.
- Open the hinged front cover on the free arm.
- Lower the feed-dog. Set knob to position . Using both thumbs, press the stitch plate up and back (Fig. 1).
- Clean the feed-dog and underside of the stitch plate.
- To refit the stitch plate on the free arm, insert the stitch plate from the rear, push forward until it engages (Fig. 2).

WARNING:

Please refer to the Safety Instructions.

To oil the hook: Apply 1-2 drops of oil after 3-4 hours' sewing.

To clean and oil the hook

- Disconnect the machine from the mains by pulling the mains plug from the socket.
- Take out the bobbin case, see page 4.
- With the thumb of the left hand, press the lower release lever to the left (Fig. 3).
- Fold down the semi-spherical locking strap with the black hook race cover.
- Take out the hook.
- Clean the top and bottom of the hook race with the cleaning brush and cotton cloth. Never use a screwdriver, scissors etc. to remove remnants of thread.
- Lightly oil the hook race with 1-2 drops of oil (Fig. 4). Insert the hook. If necessary, turn the handwheel until the hook driver is on the left (Fig. 5).
- Close the black hook race cover and locking strap. The pawl must engage.
- Check by turning the handwheel.
- Insert the bobbin case.

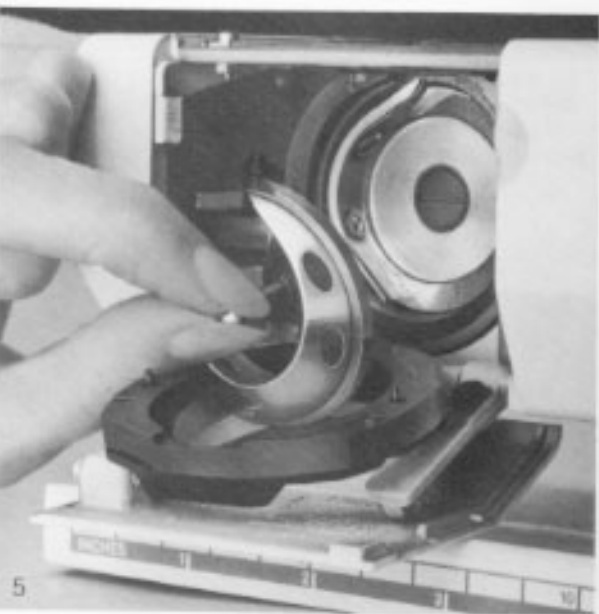

Bernina publications

It is not possible to cover more than the basics of sewing in an instruction manual. However, the creative potential of your Bernina sewing machine and Bernette overlocker is enormous. To help you use your machines to the full, Bernina regularly publishes sewing literature which covers everything from simple techniques to advanced fashion projects. Your Bernina Dealer will be delighted to give you more information.

Sewing Service Leaflets

Each issue of our Sewing Service Leaflets deals with a particular sewing technique presented in easy to follow steps. Success is guaranteed!

Bernina Creative Sewing

The Bernina Creative Sewing magazine appears twice yearly. Fashion, «Couture Rapide», home decoration, sewing for teens and twens and craft projects are all regular features of the magazine. Special sewing techniques which are featured in the sewing projects are described in detail in words and pictures. Unusual and imaginative ideas are also included from enthusiastic sewers around the world. Read about new sewing developments and trends in the comfort of your own home. The Creative Sewing magazine is a source of inspiration for all sewers. Ask your Bernina Dealer and learn how to get the most out of your machines.

Bernina Collection

These booklets deal with one particular theme in all its variations. Basic information, pattern suggestions, detailed sewing instructions with coloured illustrations and many tips and tricks of the trade will turn you into a sewing pro in no time at all. They are issued two to three times a year, so be sure to ask your Bernina Dealer when the next one is expected.



Index

A		F		N		R	
Accessories box		Fault prevention	38	Neckband		Red stitches	
- fitting	2	Faulty tension	38	- with overlock seam	22	- decorative	15
- removing	2	Feed-dog		- with visible seam	22	- practical	15
B		- and fabric feed	10	Needle		- selecting	21
Basic setting scale	20	- and sewing corners	10	- and fabric	11	Reinforced overlock	
Blind hemming	28	- and stitch length	10	- and thread	11	seam	25
Bobbin		- lowering	7	- and the sewing		Reverse sewing	18
- inserting into bobbin		Flat joining seams	24	machine	11	Ruler/Template	36
case	5	Foot control unit	3	- breaks	38		
- winding	4	Forward sewing	18	- condition	11	S	
Bobbin case		G		- inserting	8	Satin stitch	19
- inserting into book	5	Green stitches		- position	18	Seams	
- removing	4	- decorative	14	- special	12	- Double overlock	25
Bulbs		- practical	14	- the importance of	11	- Flat	25
- changing	39	- selecting	20	- /thread table	11	- Reinforced overlock	25
- inserting	39	H		O		- Stretch	24
Buttonholes	30, 31	Hems - blind	28	Oiling and cleaning	40	- Triple zig-zag	23
C		Hems - visible		Open seams	24	- Zig-zag	24
Carrying case	2	- with Jersey stitch	23	Overlock seams	24	Securing the ends	18
Cleaning and oiling	40	- with Triple zig-zag	23	Oversewing edges	19	Securing thick seams	18
D		- with Vari-overlock	23	P		Selecting	
Darning	34	I		Patching		- green stitches	20
Darning with small		Interlock fabric		- Jersey stitch	32	- red stitches	21
darning ring	35	- mending	32	- Running stitch	33	«Sewing Club»	
Decorative		K		Pattern indicator	15	magazine	41
stitches	14, 15	Knitted fabrics		Plastics	26	Sewing knitted fabrics	22
Double overlock		- sewing	22	Power switch	3	Sewing light	3
seam	25	L		Practical stitch		Sewing Service	
E		Leaflets - Sewing		- hems	23	leaflets	41
Edge stitching	29	Service	41	- seams	24, 25	Sewing tips	16
Edges		Leather	26	Practical stitches		Shirring elastic	
- oversewing	19	Lower thread		- green	14	- edges	32
Edging with shirring		- winding	4	- red	15	Straight stitch	18
elastic	32	M		Presser feet		Stretch seam	24
Elastic-shirring	32	Mains cable	3	- an aid to sewing	13		
		Maintenance -		- changing	8		
		cleaning and oiling	40	Publications	41		
		Magazine - «Sewing					
		Club»	41				
		Mending					
		- interlock fabric	32				
		- tears with Running					
		stitch	33				
		- woven fabrics	33				
		Motor	3				

Index

T	
Tension	7
Thread	
- bringing up the lower thread	7
- /needle table	11
- tension	7
- upper	6
Thread breaks	
- lower	38
- upper	38
Top stitching	29
Triple straight stitch seam	24
V	
Vari-overlock seam	25
Visible hem	
- with Jersey stitch	23
- with Triple zig-zag	23
- with Vari-overlock	23
Z	
Zig-zag	
- close - satin stitch	19
- setting	19
Zig-zag seam	24
Zips	26

WARNING:

Before using your sewing machine, please read the Safety Instructions.

The right to make constructional changes differing from text and illustrations reserved.

Sollte diese Maschine in ein anderes Sprachgebiet verkauft werden, fordern Sie beim nationalen Importeur oder Bernina-Händler eine Bedienungsanleitung in der entsprechenden Sprache an.

If this machine has been purchased in a foreign country, please request an instruction manual in your own language from the national importer or a Bernina dealer.

Si cette machine est vendue dans une autre région linguistique, demandez à l'importateur national ou à l'agent Bernina, un manuel d'instructions dans la langue correspondante.

In caso questa macchina fosse venduta in un territorio di lingua diversa si prega di richiedere il libretto d'istruzione nella lingua adeguata presso l'importatore nazionale oppure presso un rivenditore Bernina.

Si esta máquina se vende en otra región lingüística entonces pida Vd. de su importador nacional o del representante Bernina un manual de instrucciones en el idioma correspondiente.

Indien deze machine in een ander taalgebied werd gekocht, kunt u bij de nationale importeur of Bernina vakhandelaar een handleiding in de overeenkomstige taal aanvragen.

Skulle denne maskine blive solgt i et andet sprogområde, bedes du henvende dig hos den nationale Bernina-importør eller en Bernina-forhandler, hvor du kan købe en brugsanvisning på det ønskede sprog.

Om den här maskinen har köpts i ett annat land, var vänlig beställ en instruktionsbok på Ditt eget språk från importören eller en Bernina-återförsäljare.

Er denne maskinen kjøpt i utlandet, kan instruksjonsbok bestilles på ditt eget språk fra Bernina importøren eller nærmeste Bernina forhandler.

Tarvittaessa voit tiedustella omakielistäsi käyttöohjekirjaa Bernina-maahantuojalta tai jälleenmyyjältä.

SE ESTA MÁQUINA FOI COMPRADA NUM PAÍS ESTRANGEIRO, DEVER-SE-A PEDIR O MANUAL DE INSTRUÇÕES NAQUELA LÍNGUA AO IMPORTADOR NACIONAL OU AO FORNECEDOR DA BERNINA.

ΑΝ Η ΜΗΧΑΝΗ ΕΧΕΙ ΑΓΟΡΑΣΤΕΙ ΣΕ ΜΙΑ ΞΕΝΗ ΧΩΡΑ, ΠΑΡΑΚΑΛΩ ΖΗΤΗΣΤΕ ΕΝΑΝ ΟΔΗΓΟ ΛΕΙΤΟΥΡΓΙΑΣ ΣΤΗΝ ΔΙΚΗ ΣΑΣ ΓΛΩΣΣΑ ΑΠΟ ΤΟΝ ΓΕΝΙΚΟ ΑΝΤΙΠΡΟΣΩΠΟ ΤΗΣ BERNINA Η ΑΠΟ ΤΟΥΣ ΠΩΛΗΤΕΣ ΤΗΣ BERNINA.

WARNING:

Do not touch the blades
or the needle when the
machine is running.

BERNINA®

© Copyright 1992 by Fritz Gegauf AG, Steckborn