

BERNINA⁺

Overlocker / Serger Instruction Manual



BERNINA⁺ 2500DCET

IMPORTANT SAFETY INSTRUCTIONS

When using an electrical appliance, basic safety precautions should always be followed, including the following. Read all instructions before using this overlock sewing machine.

DANGER

To reduce the risk of electric shock:

1. The appliance should never be left unattended when plugged in.
2. Always unplug this appliance from the electric outlet immediately after using and before cleaning.
3. Always unplug before relamping. Replace bulb with the same type rated max. 12 volts/5 watts.
11. Never drop or insert any object into any opening.
12. Do not use outdoors.
13. Do not operate where aerosol (spray) products are being used or where oxygen is being administered.
14. To disconnect, turn all controls to the off («0») position, then remove plug from outlet.
15. Do not unplug by pulling on cord. To unplug, grasp the plug not the cord.
16. Basically, the machine should be disconnected from the electricity supply when not in use.
17. This appliance is provided with double insulation (except USA/CANADA). Use only identical replacement parts. See instructions for servicing of double insulated products.

WARNING

To reduce the risk of burns, fire, electric shock or injury to persons:

1. Do not allow this appliance to be used as a toy. Close attention is necessary when this appliance is used by or near children.
2. Use this appliance only for its intended use as described in this manual. Use only attachments recommended by the manufacturer as contained in this manual.
3. Never operate this appliance if it has a damaged cord or plug, if it is not working properly, if it has been dropped or damaged or dropped into water. Return the appliance to the nearest authorized dealer or service center for examination, repair, electrical or mechanical adjustment.
4. Never operate the appliance with any air openings blocked. Keep ventilation openings of the sewing machine and foot controller free from accumulation of lint, dust and loose cloth.
5. Keep fingers away from all moving parts. Special care is required around the sewing needle and knife.
6. Always use the proper needle plate. The wrong plate can cause the needle to break.
7. Do not use bent needles.
8. Do not pull or push fabric while stitching. It may deflect the needle causing it to break.
9. Switch the sewing machine off («O») when making any adjustments in the needle area, such as threading needle, changing needle, threading looper, or changing presser foot and the like.
10. Always unplug the machine from the electrical outlet when removing covers, lubricating or when making any other user servicing adjustments mentioned in the instruction manual.

SERVICING DOUBLE-INSULATED PRODUCTS

(except USA/CANADA)

In a double-insulated product, two systems of insulation are provided instead of grounding. No grounding means is provided on a double-insulated product nor should a means for grounding be added to the product. Servicing a double-insulated product requires extreme care and knowledge of the system and should only be done by qualified service personnel. Replacement parts for a double-insulated product must be identical to those parts in the product. A double insulated product is marked with the words «DOUBLE INSULATION» or «DOUBLE INSULATED». The symbol  may also be marked on the product.

SAVE THESE INSTRUCTIONS!

This overlock/cover stitch machine is intended for household use only.



Dear Customer

Congratulations on the purchase of your BERNINA 2500DCET overlocker. You are now the proud owner of an overlock sewing machine which fulfills every expectation in terms of use and quality. The unique stitch selection and pre-set tensions make sewing easier than ever and will give you years of pleasure.

Our comprehensive instruction manual takes you step by step through the features and handling of your new machine. We also provide you with tips and suggestions for using the various overlock stitches, roll hem, cover and chain stitch. On the last page of the manual, you will find a list of optional accessories and BERNINA services which provide even more scope for getting the most out of your new overlocker.

If you require any further information about your overlocker or sewing in general, please do not hesitate to contact your BERNINA dealer who will be delighted to help you.

We wish you happy and successful overlocking.

Hanspeter Ueltschi
President

BERNINA INTERNATIONAL AKTIENGESELLSCHAFT
BERNINA International AG, CH-8266 Steckborn

	5
	6
Details of the machine	11
Setting up the machine	14
Functions and general operating instructions	23
Needles, thread, fabric	24
Stitch chart and stitch selection	30
Threading instructions for overlock, cover/chain stitch and top & bottom cover stitch	31
Overlock threading	35
Overlock test sewing and fine tuning	38
Cover/chain- and top & bottom cover stitch functions and general instructions	42
Cover stitch threading	48
Top & bottom cover stitch threading	51
Top & bottom cover stitch / Cover stitch test sewing and fine tuning	53
Chain stitch threading (position G)	55
Chain stitch test sewing and fine tuning	57
Converting from overlock to cover/chain stitch	58
Converting from cover stitch position F (4 thread cover stitch) top & bottom cover stitch (position H)	59
Converting from top & bottom cover stitch (position H) to cover/chain stitch position F (4 thread cover stitch)	60
Converting from cover/chain stitch to overlock	61
Overlock practical sewing, needles and threads	67
Cover stitch/ top & bottom cover stitch practical sewing	70
Chain stitch practical sewing	71
Maintenance	72
Trouble shooting	74
Index	76
Technical information	77
Optional Accessories	78
Bernina publications	

Details of the machine

BERNINA 2500DCET cover/chain stitch mode

6

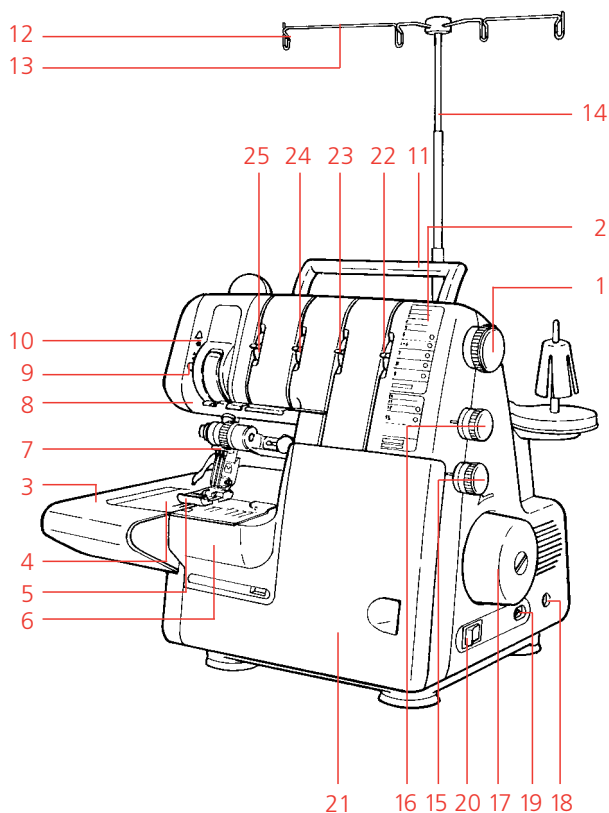

View from the front

- 1 Stitch selection dial
- 2 Stitch display
- 3 Cloth plate/free arm
- 4 Stitch plate
- 5 Standard presser foot with tape guide
- 6 Cover stitch extension plate
- 7 Needle clamp
- 8 Sewing light
- 9 Needle stop
- 10 Safety control light
- 11 Carrying handle
- 12 Thread guide
- 13 Thread guide support
- 14 Support rod
- 15 Differential feed dial
- 16 Stitch length dial
- 17 Handwheel
- 18 Foot control socket
- 19 Machine socket
- 20 Power switch
- 21 Looper cover
- 22 Lower looper fine tuning (purple)
- 23 Needle R fine tuning (brown)
- 24 Needle C fine tuning (green)
- 25 Needle L fine tuning (yellow)

BERNINA 2500DCET top & bottom cover stitch mode

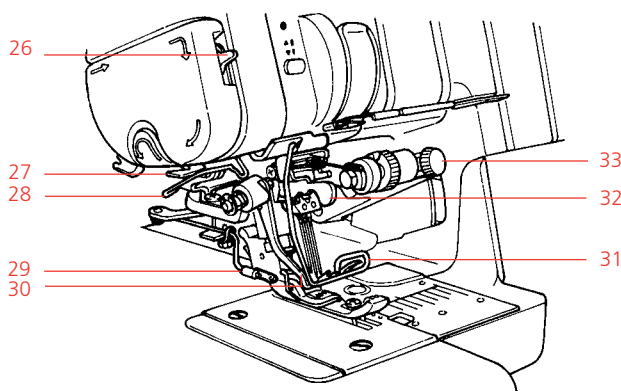

View from the front

- 26 Wiper fine tuning (grey)
- 27 Thread guide
- 28 Thread eyelet
- 29 Feeding link guide
- 30 Wiper
- 31 Finger guard
- 32 Wiper activating lever
- 33 Upper knife arm screw

BERNINA 2500DCET overlock mode

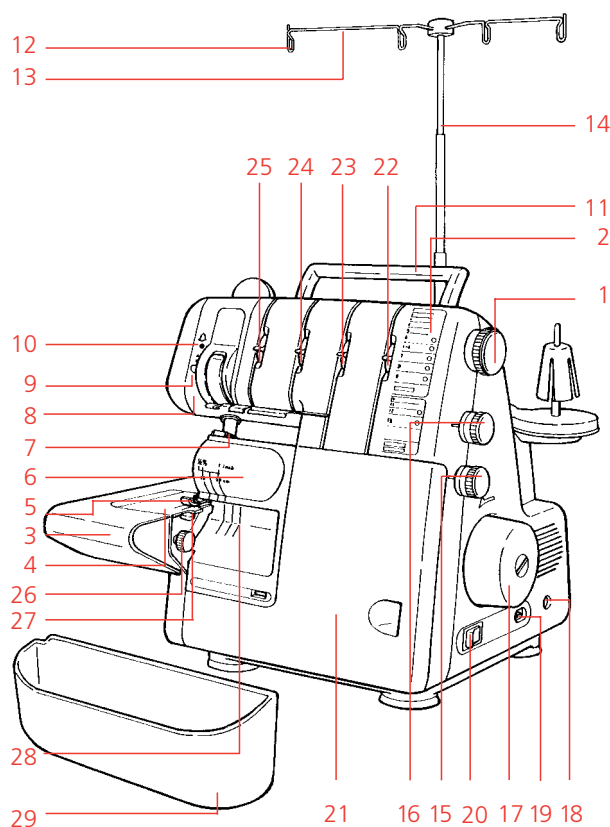

View from the front

- 1 Stitch selection dial
- 2 Stitch display
- 3 Cloth plate/free arm
- 4 Stitch plate
- 5 Standard presser foot with tape guide
- 6 Knife guard
- 7 Needle clamp
- 8 Sewing light
- 9 Needle stop
- 10 Safety control light
- 11 Carrying handle
- 12 Thread guide
- 13 Thread guide support
- 14 Support rod
- 15 Differential feed dial
- 16 Stitch length dial
- 17 Handwheel
- 18 Foot control socket
- 19 Machine socket
- 20 Power switch
- 21 Looper cover
- 22 Lower looper fine tuning (red)
- 23 Upper looper fine tuning (blue)
- 24 Needle C fine tuning (green)
- 25 Needle L fine tuning (yellow)
- 26 Cutting width dial
- 27 Roll hem selection lever
- 28 Cutting lines
- 29 Waste collector

BERNINA 2500DCET overlock mode (Detailed)

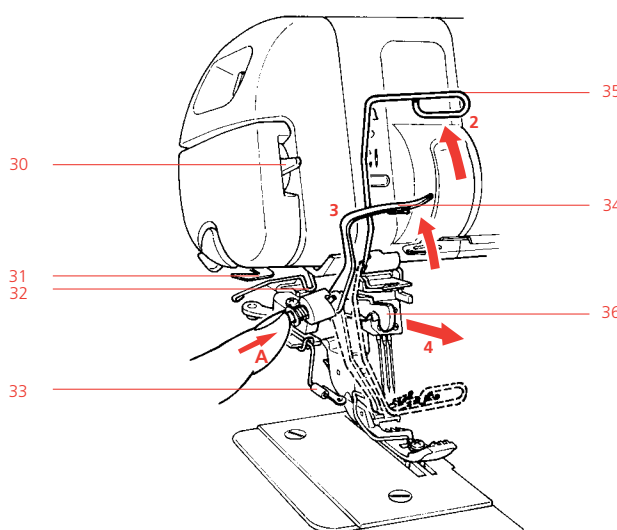

- 30 Wiper fine tuning (grey)
- 31 Thread guide
- 32 Thread eyelet
- 33 Feeding link guide
- 34 Wiper
- 35 Finger guard
- 36 Wiper activating lever

Details of the machine

BERNINA 2500DCET overlock mode

8 View from the back

- 38 Thread stand
- 39 Foam pad
- 40 Spool stabilizers
- 41 Spool pin
- 42 First thread guide
- 43 Presser foot pressure control
- 44 Presser foot lifter
- 45 Light switch
- 46 Thread cutter
- 47 Foot control
- 48 Power cord

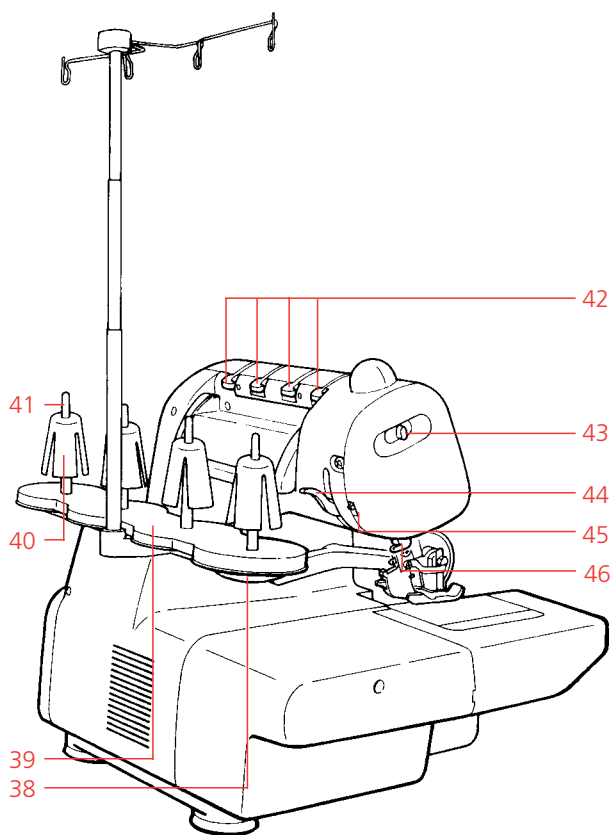

Foot control:
Model Nr. YC-425

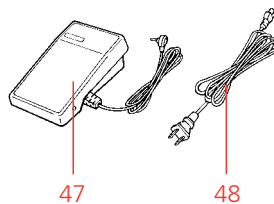

View with looper cover open

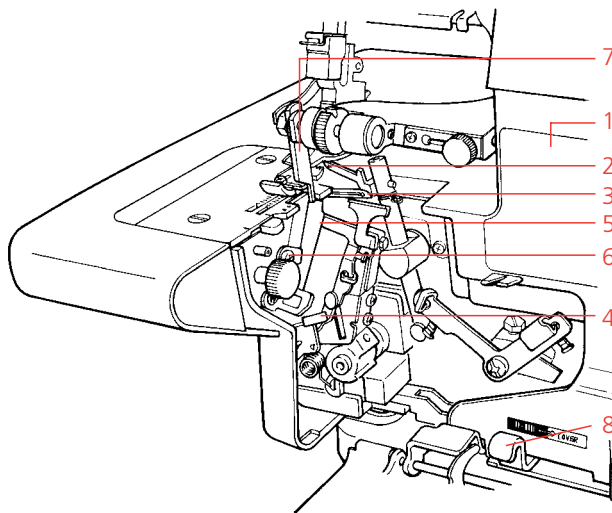

- 1 Threading diagram
- 2 Upper looper (blue)
- 3 Lower looper (red)
- 4 Lower looper auto-threader
- 5 Lower knife
- 6 Lower knife setscrew
- 7 Upper knife
- 8 Conversion arm

9

Accessories in looper cover

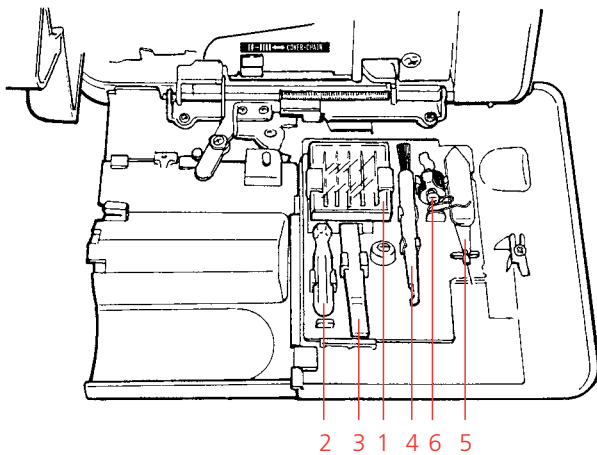

2 3 1 4 6 5

The most important threading and machine accessories are neatly stored in the looper cover and always to hand.

- 1 Household needles 130/705H (2x70, 3x80)
- 2 Small screwdriver
- 3 Tweezers
- 4 Brush/needle inserter
- 5 Needle and looper threader
- 6 Upper looper converter

Details of the machine

Accessories

10

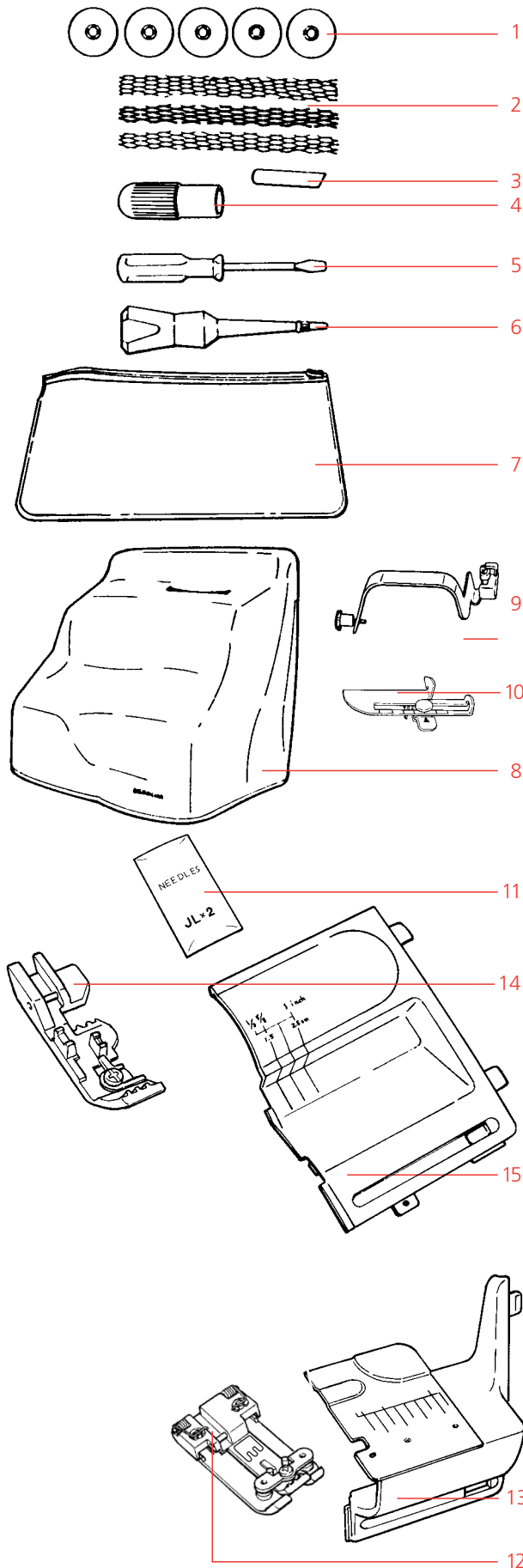

All other accessories are stored in the accessory bag and box.

- 1 Spool caps
- 2 Nets
- 3 Spare knife
- 4 Bulb holder
- 5 Large screwdriver
- 6 Oiler
- 7 Accessory bag
- 8 Dust cover
- 9 Deco guide
- 10 Seam guide right
- 11 Needle set JLx2 (3x 80)
- 12 Cover stitch presser foot *
- 13 Cover/chain stitch extension plate
- 14 Standard foot with tape guide
- 15 Knife guard

*** Cover stitch presser foot**
 Instructions for using the cover stitch presser foot (compensating foot) are on page 16.

Cover stitch:
 Depending on whether your machine is delivered in overlock or cover stitch mode, either of the accessories 13, 14 or 15 will be attached to the machine.

Attaching the foot control

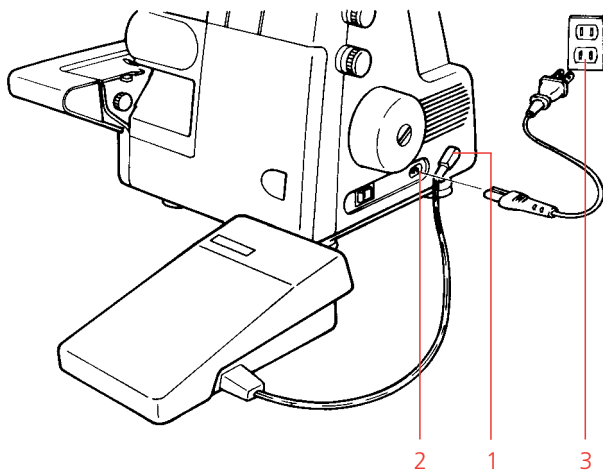

2500DCET

Plug the foot control into the machine socket (1) on the right side of the machine. Plug the power cord into the machine socket (2) and into the mains socket (3).

Warning

This appliance has a polarized plug (one blade wider than the other). To reduce the risk of electric shock, this plug is intended to fit in a polarized main socket only one way. If the plug does not fit fully in the polarized main socket, reverse the plug. If it still does not fit, contact a qualified electrician to install the proper polarized main socket. Do not modify the plug in any way (for USA, Canada only). For the BERNINA 2500DCET use only the foot control model YC-425 (USA, Canada).

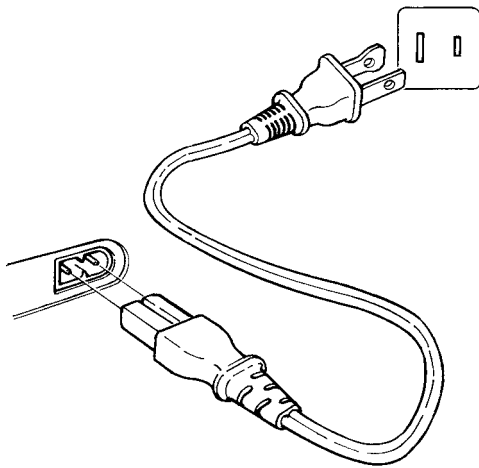

Sewing speed

Decrease or increase the pressure on the electronic foot control for fully variable speed control.

The maximum sewing speed for:	
Overlock stitch mode A to E	1500 s.p.m.
Cover/chain stitch mode F and G	800 s.p.m.
Top&bottom cover stitch mode H	500 s.p.m.

The maximum sewing speeds are automatically set by the stitch selection dial.

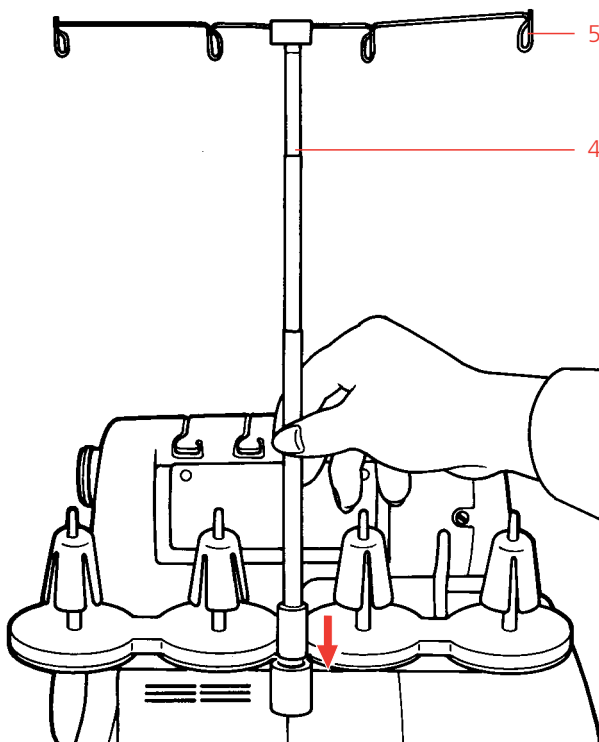

Thread stand

Push the support rod firmly into the socket on the back of the machine.

Raise the support rod (4) fully, turning slightly until the positioning catches engage. Position the thread guide (5) on the thread stand so that it is parallel to the machine.

Setting up the machine

12

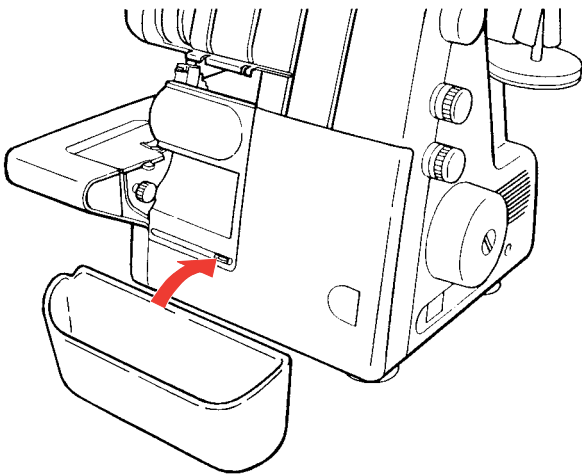

Waste collector

Hang the waste collector onto the opening provided on the looper cover. It catches the cut-off fabric as you sew, keeping your working area neat and tidy.

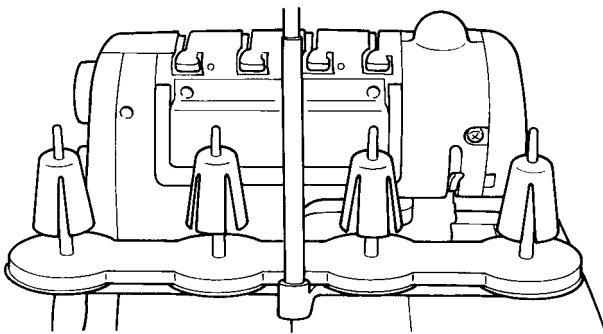

Thread, cones, spools

Cones or domestic spools in all sizes can be used on your BERNINA overlocker.

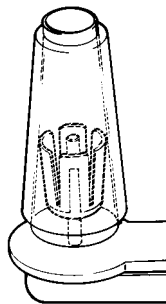

Place the stabilizers on the spool pins when using thread cones.

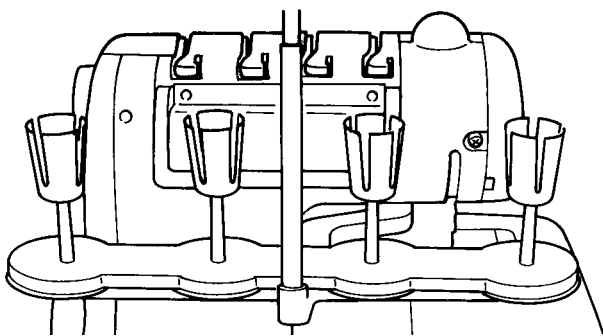

When sewing with large industrial spools, use the stabilizers upside down, i.e. with the wider edge at the top.

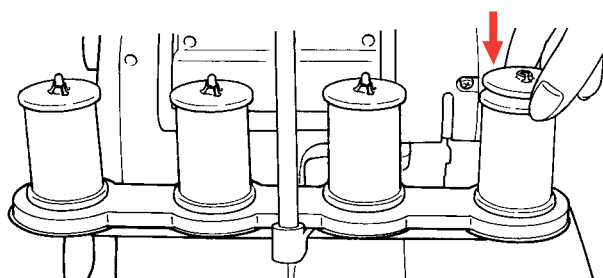

Remove the stabilizers for household spools, but secure the spools with the spool holder caps, rounded side downwards.

Placing the spool holder for the top & bottom cover stitch thread

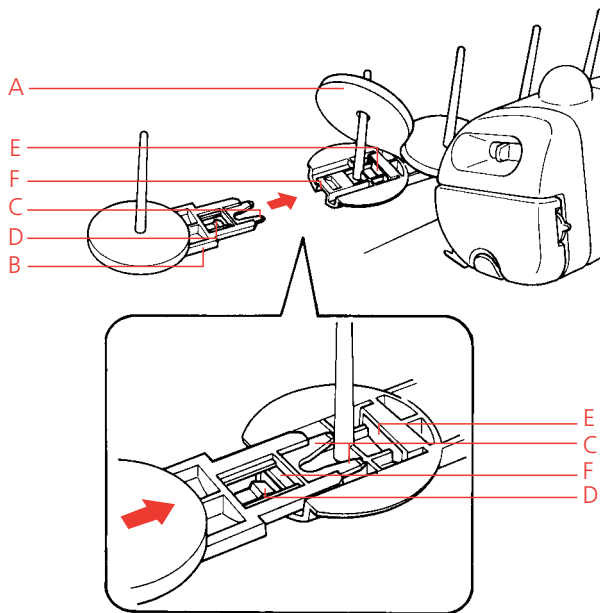

Lift the foam pad (A), slide the guide tabs (C) of the spool holder (B) into the guide of the upperside of the spool holder from left to right into position (E) and press until tab (D) clicks into the underside of rib (F).

Functions and general operating instructions

14

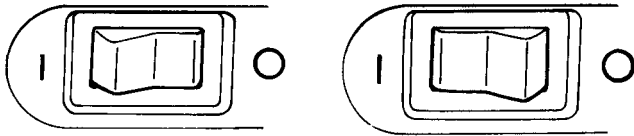

Power switch

The power switch is on the handwheel side of the machine in front of the machine socket.

O = OFF
I = ON

Light switch

The light switch is positioned on the rear left side of the machine to the left of the presser foot lifter.

1 = ON
2 = OFF

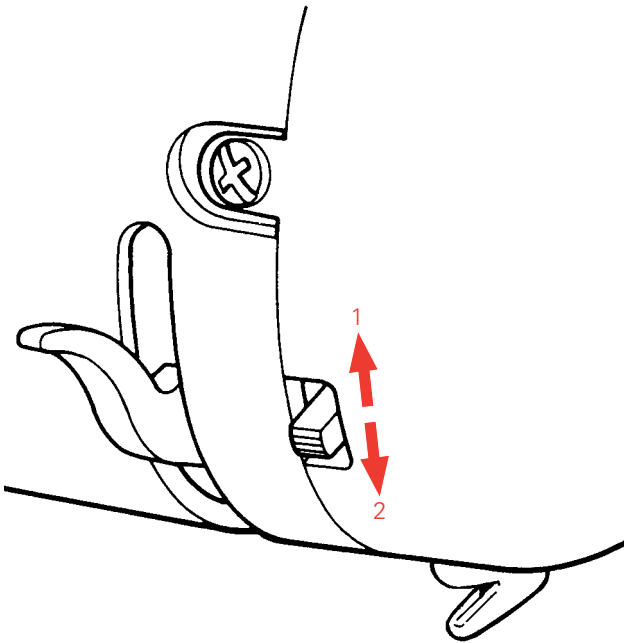

Electronics/Safety/Needle stop

Your Bernina overlocker is equipped with electronic operating and safety features.

Micro-safety switch:

When the looper cover is open, the electricity supply to the motor is automatically interrupted. The machine will not sew but the light remains on for threading etc.

Needle stop:

The Needle stop for overlock stitches (positions A to E) is generally up, i.e. when you stop sewing, the needle(s) will stop in their highest position, the ideal position for threading or changing needles. To lower the needle(s), press the Needle stop button (3).

The Needle stop for cover and chain stitch (positions F/G/H) is generally down, i.e. cover and chain stitch formations end with the needle in the fabric.

Safety control lamp:

The machine will not sew if it has not been prepared correctly. When the foot control is depressed, the safety control lamp will light up (4).

The control lamp also lights up when the presser foot is raised, when the presser foot is swung out or the looper cover is open.

Safety cut-out

If overheating should occur, the motor will cut-out after 2 seconds, after cooling down, sewing can be continued.

Note:

If you turn the stitch selection dial while sewing, the control lamp will blink and the machine will stop.

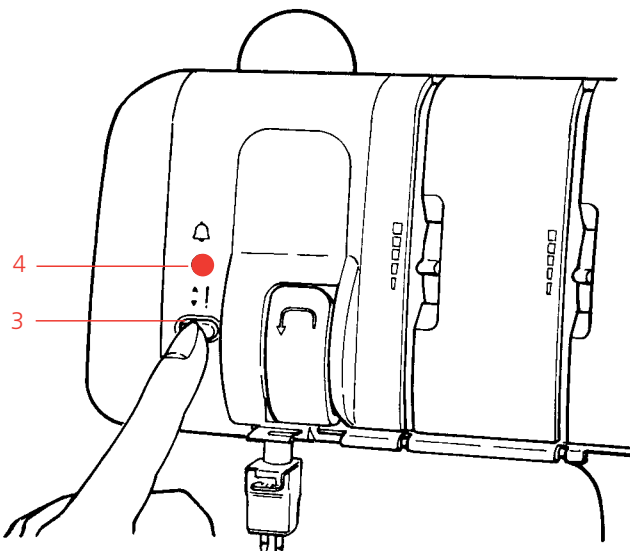

Handwheel

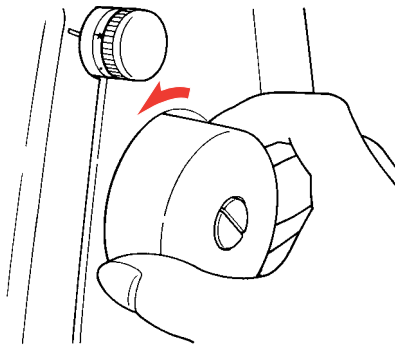

The handwheel turns counter-clockwise as on a household sewing machine.

15

Looper cover

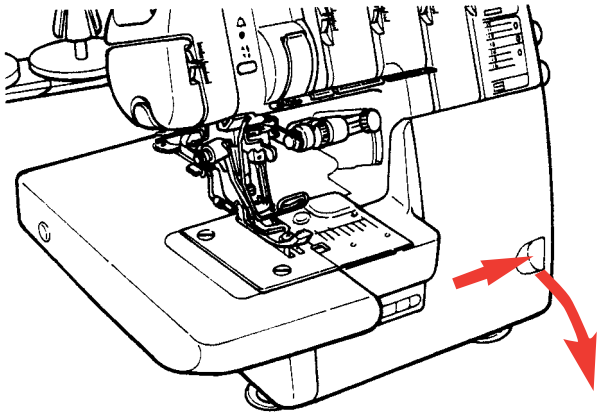

To open the looper cover, press to the right and tilt the cover towards you.

To close the cover, push it up and press lightly to the left and it will engage automatically.

Cloth plate / free-arm

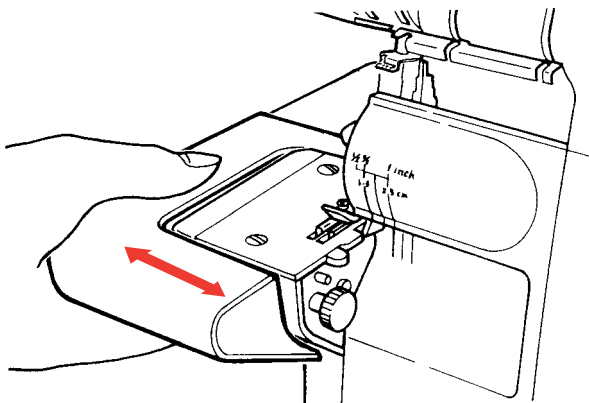

The cloth plate can be removed to expose the free arm.

To remove pull to the left.

To attach press firmly to the right until it engages.

The free arm is ideal for sewing tubular items such as ribbing, trousers and sleeve hems.

Two-step presser foot lifter

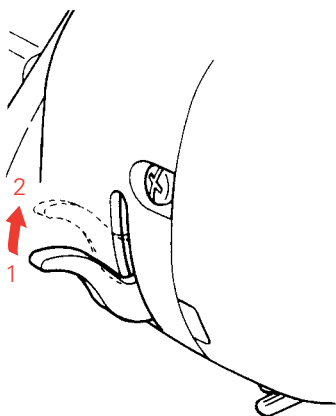

The presser foot lifter is positioned on the rear of the machine above the presser foot.

To raise the presser foot, lift the presser foot lifter until it engages (1).

It can be raised again to maximum height and held in this position to provide more space between presser foot and stitch plate for bulky items. (2).

Press the lifter down to lower the presser foot.

Note: When the presser foot is raised, all the tensions are released making it easier to thread the machine.

WARNING: If sewing in top & bottom cover stitch mode, when lifting the presser foot to its highest position (2), do not use any force.

Functions and general operating instructions

Swing-out presser foot

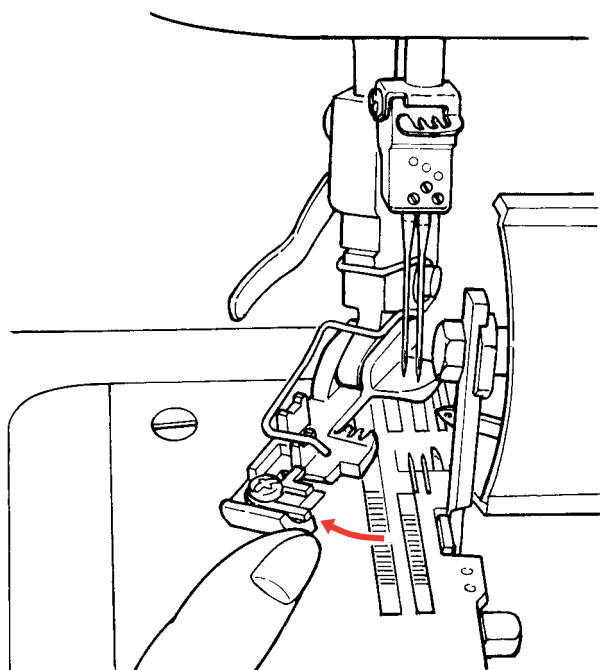

The swing-out foot (exclusive by BERNINA) provides easy access for threading needles. It also makes it easier to change the needles and insert band or elastic into the guide on the foot.

To swing out:

- Raise the needles (Needle stop).
- Raise the presser foot and swing it out to the left.

To position for sewing:

- Push the foot from left to right until it engages.
- Lower the presser foot.

Note:

The machine will not run when the foot is swung-out. An additional safety measure to prevent damage to needle(s) or machine.

Note:

Cover stitch compensating foot: To prevent damaging the needle points, the cover stitch foot (accessory) should not be swung out.

Changing the presser foot

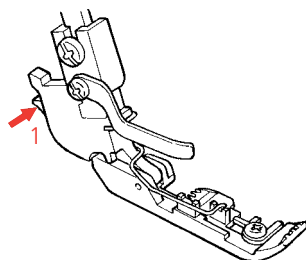

- Raise the needles (Needle stop)
- Raise the presser foot.
- Press the catch (1) to release the presser foot from the clamp (2) and remove it to the left.

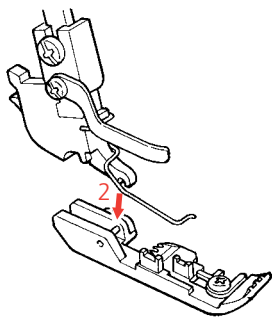

To attach the foot, place it under the shaft. The groove in the shaft should line up exactly with the presser foot pin (3). Lower the shank and the presser foot engages automatically.

The cover stitch presser foot (compensating foot – accessory) is used together with the seam guide lines on the extension plate and for work where precise guiding is necessary.

The cover stitch presser foot consists of a solid centre section and two spring-loaded side sections. The indents on the centre section (1) indicate the needle positions and act as guides.

The spring-loaded side sections (2) guide the fabric and prevent sideways movement. Perfect for topstitching hems with elastic, folded edges, seams and ribbings as well as bindings or sewing on lace or elastic.

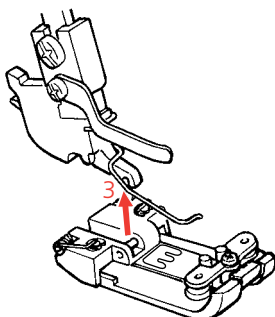

Note:

Cover stitch compensating foot: To prevent damaging the needle points, the cover stitch foot (accessory) should not be swung out.

Stitch length

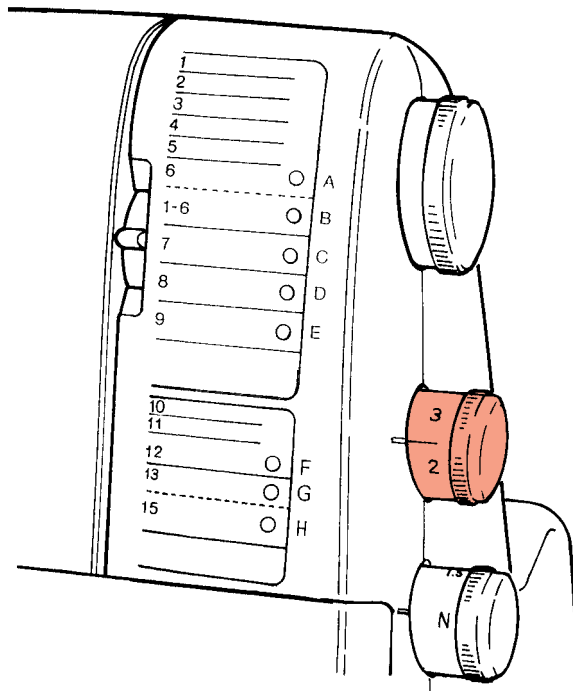

Every stitch equals one complete feed-dog movement. The amount of movement is determined by the selected stitch length.

The stitch length is infinitely variable from 1–4 mm and can be adjusted while sewing. Simply turn the stitch length dial in the direction desired.

Most overlock work is done with a basic stitch length setting of 2.5 mm (marking on the dial).

Most cover stitch work is done with a stitch length of between 3 and 4.

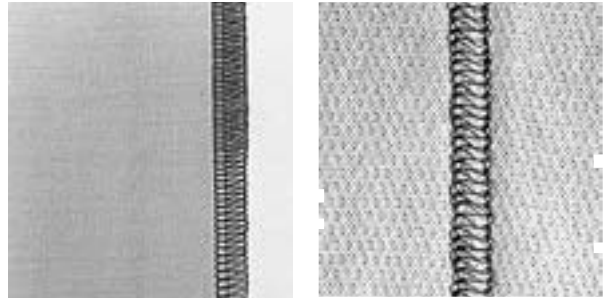

17

Cutting width

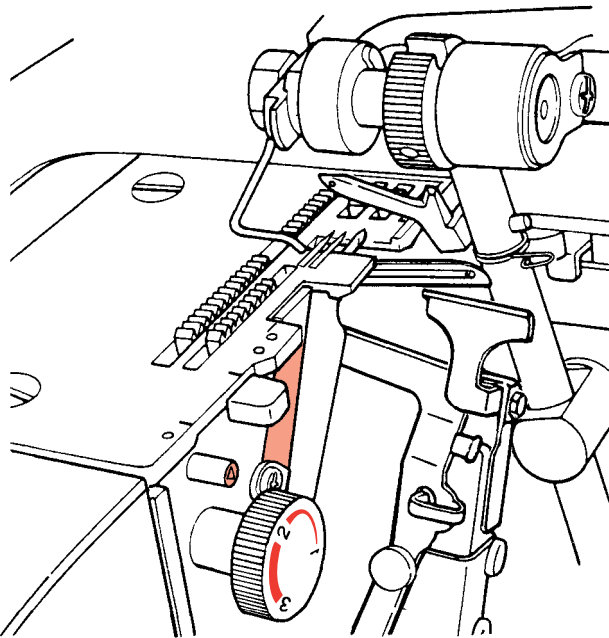

Adjusting the cutting width for overlock stitches:

Turn the dial in the direction desired. The upper knife adjusts automatically to the position of the lower knife. The stitch width of overlock stitches is determined by the cutting width and the needle(s) in use.

Note cover/chain stitch:

Cover and chain stitches are sewn without knives. The upper knife and upper knife arm are fully raised when the machine is in cover/chain stitch mode.

Position of knife:	1	2	3
Needle C:	3 mm	4 mm	5 mm
Needle L:	5 mm	6 mm	7 mm

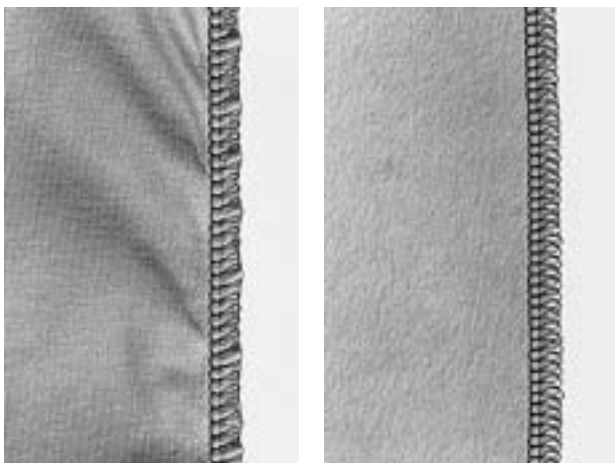

Cutting width

Narrower cutting width:

If the edges of fine fabrics curl when being sewn, reduce the cutting width by turning the dial to a lower number.

Wider cutting width:

If the loops formed on the fabric edge are too loose, increase the cutting width by turning the dial to a higher number.

Differential feed

Your BERNINA overlocker is equipped with a front (1) and a rear (2) feed dog. The two feed dogs move independently, and the distance each feed dog travels can be adjusted independently.

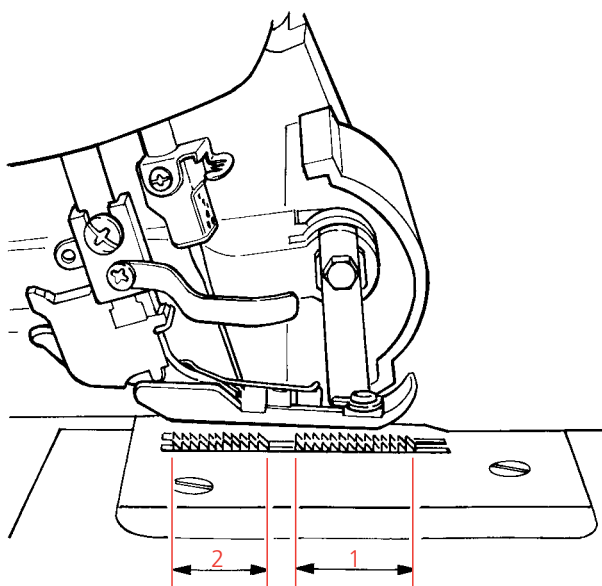

Gathering effect

This is the most common use for differential feed and is to prevent waviness or fluting in knits or puckers in fine woven fabrics.

The distance travelled by the front feed dog is greater than that of the rear feed dog. The front feed dog pushes the amount of fabric which the rear feed dog can take up unstretched (knit) or unpuckered (fine wovens) behind the needle(s) (e.g. 1.5 and 2).

Stretching effect



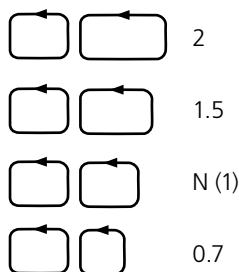

The opposite effect can be produced to prevent fine nylon jerseys or closely woven fabrics from puckering.

The distance travelled by the rear feed dog is greater than that of the front feed dog. The front feed dog holds the fabric back so that the rear feed dog can take up the fabric (slightly stretched) behind the needle(s). (e.g. 0.7).

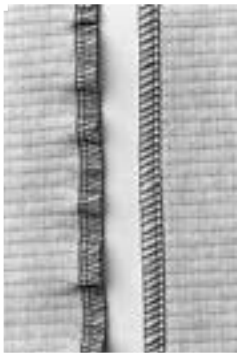
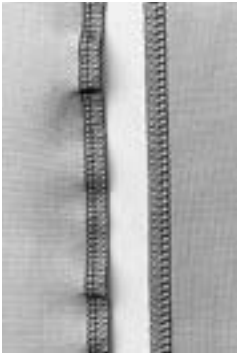
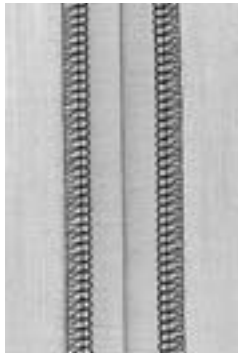

Adjusting the differential feed

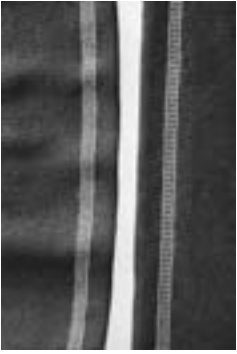
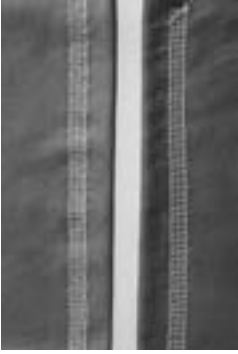
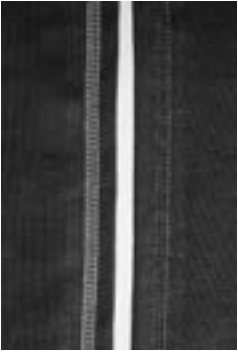
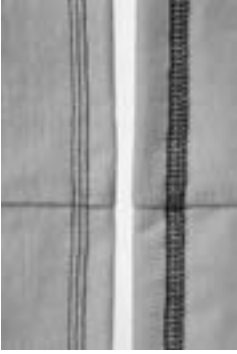
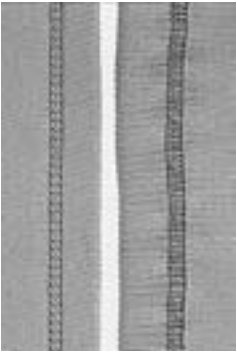
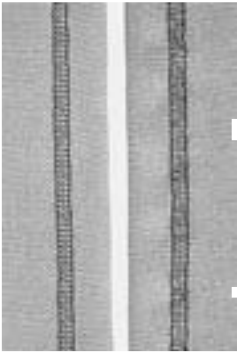
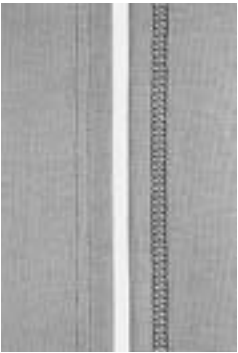
Simply turn the dial in the direction desired for fully variable adjustments while sewing. Test sew.

Setting	2	1.5	N	0.7
Effect	Gathering effect, flat seams	Gathering effect, flat seams	Normal feed	Stretching effect, pucker free seams
Overlock	Thick or loose knits, hand- knits	Fine to medium weight knits, e.g. sweatshirt, velours, interlock	Woven fabrics	Nylon jerseys, closely woven fabrics e.g Charmeuse, linings, satin, poplin.
				
4 thread cover stitch (5 thread top & bottom cover stitch)	Thick or loose knits, hand-knits	Fine to medium weight knits	Knits with the grain	Sewing over seams
				
3 thread cover stitch (5 thread top & bottom cover stitch)	Thick or loose knits, hand-knits	Fine to medium weight knits	Knits with the grain	sewing over seams
				

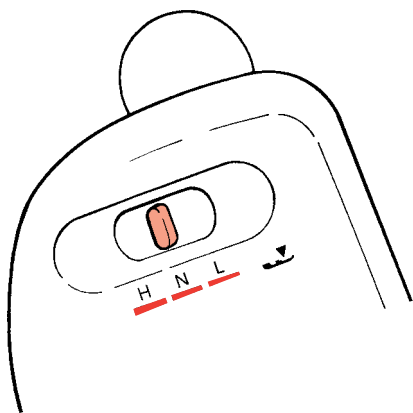

Presser foot pressure

The presser foot pressure ensures perfect fabric feed. It is factory adjusted to a medium setting.

Adjusting the pressure:

Push the lever in the direction desired.

H High pressure: For thick or stiff fabrics such as denim, tweed, linen and for sewing on elastic.

N Normal pressure: Basic setting for most normal overlock work.

L Low pressure: For light-weight or sheer fabrics such as chiffon, georgette, batiste, linings.

Note:

Seams in knitted fabrics will wave if the presser foot pressure is too high. Always set to «N» when sewing knits.

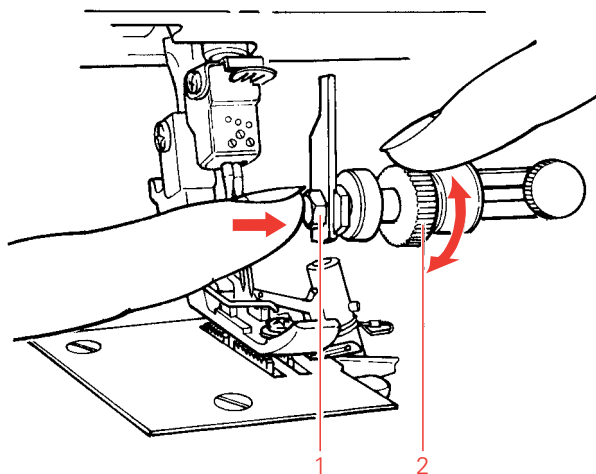

Upper knife

Raise the needle(s) to their highest position (needle stop).
Open the looper cover, if sewing in overlock mode.

To raise the knife press the upper knife holder (1) to the right.
Turn the knob (2) clockwise until the knife locks (3).

To lower, press the holder to the right and turn the dial (2) counter-clockwise until it engages. The knife engages in the cutting position.

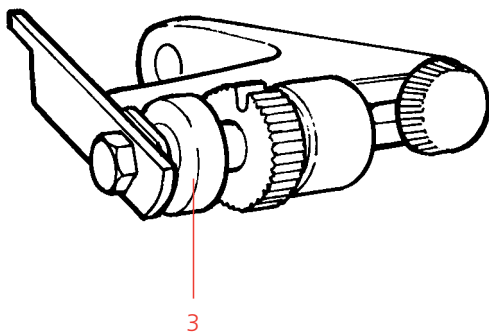

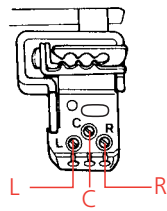

Needle clamp

BERNINA 2500DCET needle clamp

There are three needle positions (**L**, **C**, **R**) each with its own fixation screw.

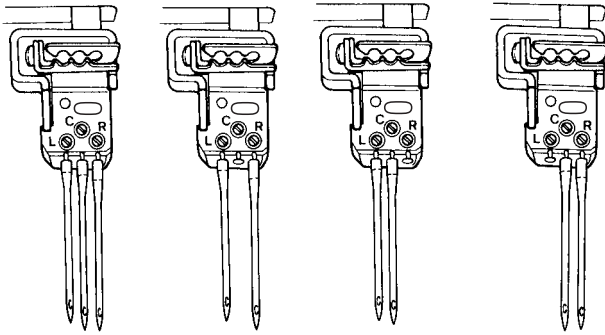

Needle positions

Needles are inserted into positions L, C or R depending on the stitch selected, which produces different stitch widths.

Note:

The third needle position (R) is for cover and chain stitch applications only!

Needle **L** and **C**
or Needle **L**
5–7 mm overlock

Needle **C**
3–5 mm overlock
2–3 mm roll hem

Needles **L**, **C** **R**
or needle **L** and **R**
5 mm cover stitch

Needles **L** and **C**
Needles **C** and **R**
2.5 mm cover stitch left or right of centre

Needles **L**, **C**, and **R**
5 mm top & bottom cover stitch

Needles **L** and **C**
2.5 mm top & bottom cover stitch

Needle **R**
Chain stitch

Note:

Remove all needle(s) not in use, and their corresponding thread(s).

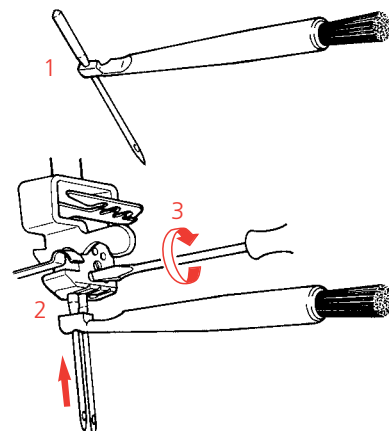
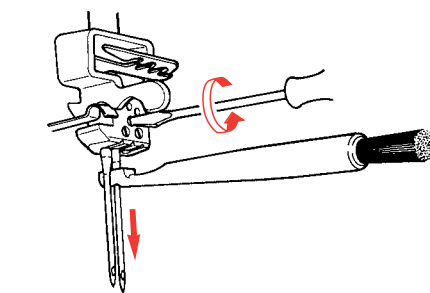

Inserting needles

Needles can be inserted quickly and easily with the practical needle inserter.

To remove:

- Raise the needles (Needle stop).
- Raise the presser foot and swing out or remove.

Loosen the fixation screw and remove the needle using the inserter. Place the replacement needle, flat sides towards the back, into the hole of the needle inserter (1) and insert the needle in the appropriate hole as far as possible into the needle clamp (2). Tighten the needle setscrew firmly (3).

Tip:

Insert the needle C first and then needle L. Needle L is slightly higher than the needle C.
Use needle R for cover and chain stitch.

Upper looper converter

22

Attach the upper looper converter for overlock stitches sewn with one looper, e.g. 2 thread roll hem or 2 thread flatlock.

- Lower the needles (press Needle stop)
- Open the looper cover

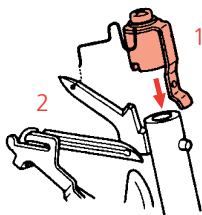

Attach the converter (stored in looper cover) to the upper looper arm (1). Insert the wire hook into the upper looper eye from back to front (2). The upper looper has now been converted, i.e. it no longer carries thread but it diverts the lower looper thread so that loops are formed round the edge of the fabric.

Tip:

Before starting to sew, check that the upper looper is correctly positioned by first turning the handwheel a few times to form a chain.

Stitch selection lever/roll hem on the stitch plate

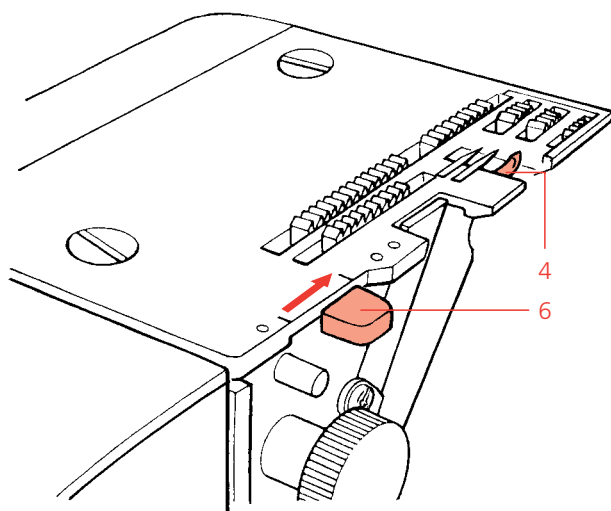

The selection lever for roll hem is integrated in the stitch plate. When the selection lever is pulled forward (3), the wide overlock stitch finger (4) is retracted to expose the roll hem pin (5). The fabric edge is rolled round the pin while sewing to produce a fine and decorative edge finish.

For overlock, push the selection lever back away from you (6).

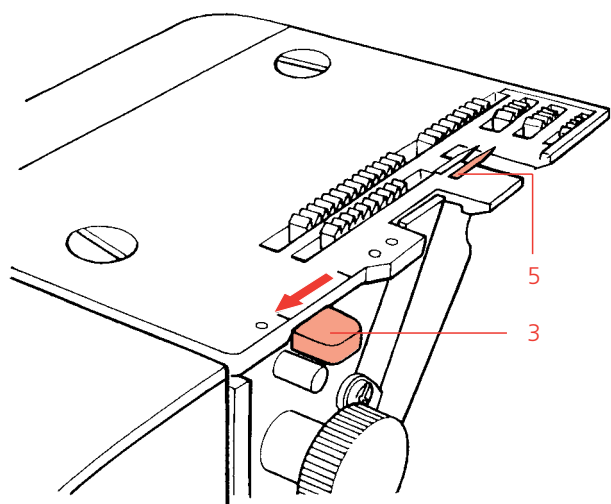

For roll hem, pull the selection lever forward towards you (3).

Needles and machine

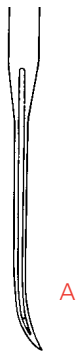

Your BERNINA overlocker is equipped with needle system 130/705 H (household needles). However for certain types of sewing, system JLx2 needles can also be used on

the BERNINA 2500DCET when sewing cover and chain stitch (Positions F and G). It is important to purchase system 130/705H needles for overlocking and

cover stitch or JLx2 needles for cover and chain stitch when replacement needles are required.

Needle and fabric

Needles must be in perfect condition. Problems can occur if needles:

- A are bent
- B are damaged or blunt
- C have hooked points

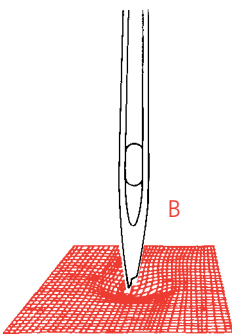

Needle and thread

The needle size used depends on the thread. The needles should be in accordance with thread used.

When sewing, the thread is fed through the long groove in the needle. If the needle is too fine, the thread does not fit into the groove and stitches will be skipped. Use

needles no. 70–90 on your BERNINA overlocker.

Thread/decorative threads

Sewing and special overlock threads are manufactured in a wide variety of types, weights and combination fibres. It is worth investing in good quality threads for perfect sewing results.

Decorative threads specially made for overlockers (available on cones) are also becoming widely available. We recommend following basic guidelines when using special threads on your overlocker:

- Purchase threads on cones or spools which are produced exclusively for overlocking.
- When using normal spools, use the spool caps (in accessory bag).
- Only use decorative threads in the loopers. The thread must move easily and without resistance through the thread guides and looper eyes.
- The thicker the thread, the longer the stitch length (3–4).
- The thicker the thread, the looser the tensions
- Sew slowly when using decorative threads. Pull the thread chain gently to the rear when starting to sew.
- Always test sew decorative threads before starting to sew your work.
- Use the deco-guide when sewing thick or decorative threads (see page 36.)

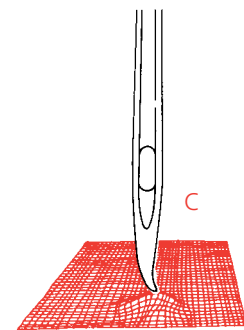

Thread, needle, application table

Thread	Needles	Where	Application
All purpose overlock thread 120/2 (polyester)	70–90	Needles-, loopers- and wiper threads	For all overlock- and cover stitch work
Polyester-continuous filaments		Loopers only	Neatening edges
Woolly nylon		Loopers and wiper only	Soft seams in knits, rolled hems
Spun Polyester	80–90	Needles-, loopers- and wiper threads	Seams in all fabrics
Embroidery/darning and decorative threads	70–90	Loopers and wiper only	Neatening edges, rolled hems and cover stitch applications

Stitch formations and stitch selection

BERNINA 2500DCET stitches

The 2500DCET sews 16 different basic stitches.

Overlock stitches are basically formed with two looper threads.

Examples:
 4 thread overlock with integrated safety seam
 3 thread overlock/flatlock/roll hem/narrow seam

A further selection of stitches can be sewn with one looper using the upper looper converter.

Examples:
 A 3 thread super stretch
 B 2 thread overlock/flatlock/roll hem

A
B
C
D
E

The BERNINA 2500DCET can be converted to cover and chain stitch. The cover stitch is 2.5/5 mm wide and is sewn with two or three needles and the lower looper (the upper looper is released and the upper knife and knife arm are raised).

Chain stitch is sewn with one needle and the lower looper (the upper looper is released and the upper knife and knife arm are raised).

The top & bottom cover stitch is 2.5/5 mm wide and is sewn with two or three needles, a wiper thread along with a lower looper (the upper looper is released and the upper knife and knife arm are raised).

F
G
H

Important!
 Remove all needles that are not in use and their corresponding threads.

Stitch display /stitch selection dial

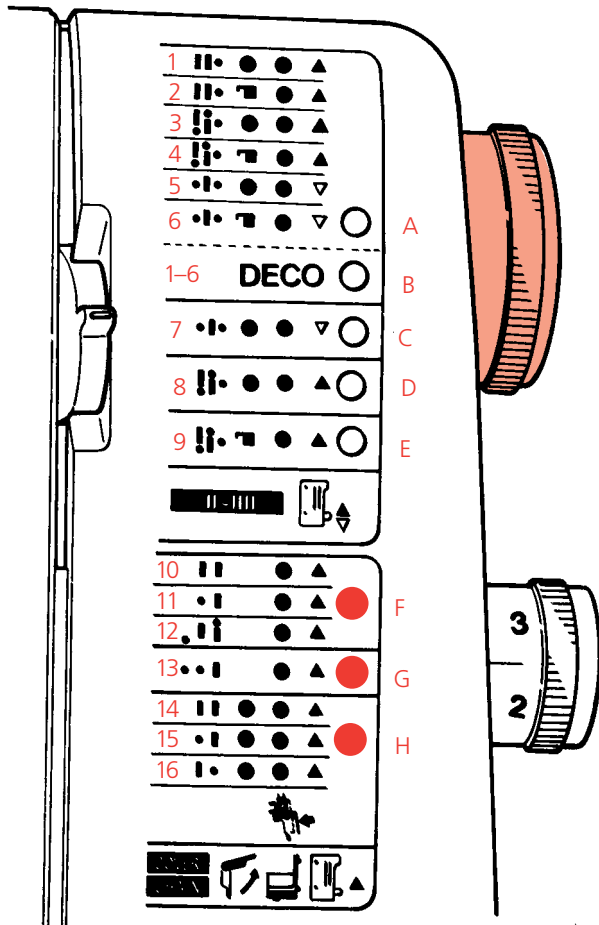

The Bernina 2500DCET is equipped with a one dial stitch selection function. The basic tension settings for sixteen different stitches are distributed over eight positions. The position desired can be selected by simply turning the stitch selection dial. An LED display indicates the selected position.

The positions A, C, D and E are adjusted for overlock stitches using standard overlock thread.

The stitches on Position B are the same as position A but with pre-set tensions for woolly nylon or a similar decorative thread in the loopers.

Position F is pre-set for cover stitch, G for chain stitch using all-purpose overlock thread and H for top & bottom cover stitch.

25

Stitch display

The stitch display provides all the information you need about stitches and threading.

Symbols:

Yellow line = insert needle **L** and thread

Green line = insert needle **C** and thread

Brown line = insert needle **R** and thread

Blue dot = thread the upper looper through the blue guides

Red dot = thread the lower looper through the red guides

Purple dot = thread the lower looper through the purple guides

Small black dot = do not thread needle, remove needle

■ Attach the upper looper converter (upper looper is not threaded)

▲ Move stitch selection lever to overlock

▼ Move stitch selection lever to roll hem











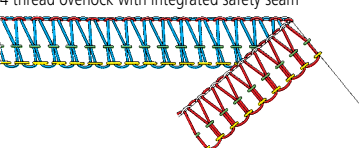

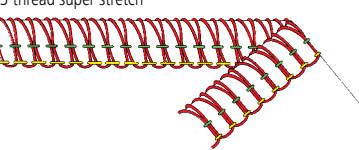

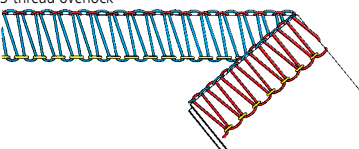

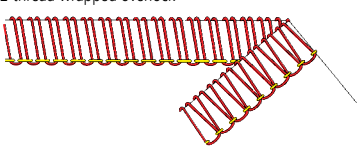

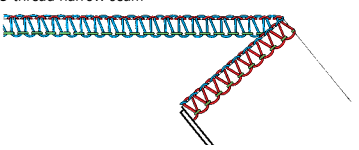
⤴ Raise the upper knife and upper knife arm

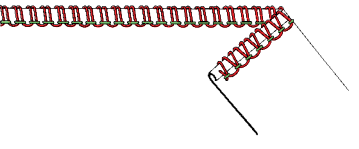

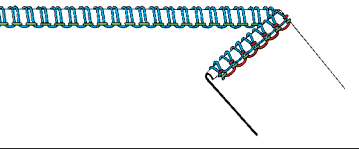

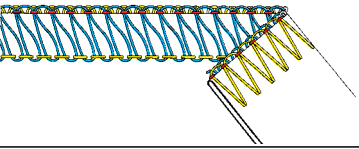

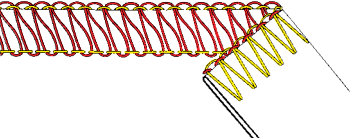
📄 Attach the cover stitch extension plate

👉 Lower the wiper and finger guard

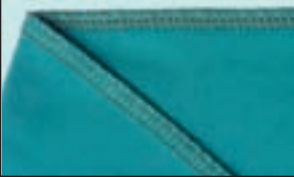
👉 Press in wiper activating lever

Stitch Chart

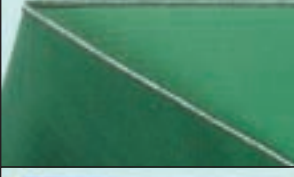
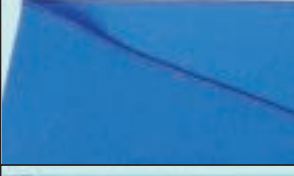
No.	Stitch	Symbols	Stitch width	Pos.	Thread	Basic settings
1	4 thread overlock with integrated safety seam 		5-7 mm needles C and L	A	Loopers and needles: all-purpose overlock thread, polyester thread	Stitch length: 2.5 Cutting width: 2 Differential: N - 2 (knits), N -0.7 (wovens)
				B	Loopers: woolly nylon Needles: all-purpose overlock thread, polyester thread	
2	3 thread super stretch 		5-7 mm needles C and L	A	Lower looper and needles: all-purpose overlock thread, polyester thread	Stitch length: 2.5 Cutting width: 1-2 Differential: N
				B	Lower looper: woolly nylon Needles: all-purpose overlock thread, polyester thread	
3	3 thread overlock 		3-5 mm needle C 5-7 mm needle L	A	Loopers and needle: all-purpose overlock thread, polyester thread, embroidery or darning thread	Stitch length: 2.5 Cutting width: 2 Differential: N-1.5 (knits), 0.7-N (wovens)
				B	Loopers: woolly nylon or similar decorative thread Needle: all-purpose overlock thread, polyester thread	
4	2 thread wrapped overlock 		3-5 mm needle C 5-7 mm 5-7 mm needle L	A	Lower looper: woolly nylon all-purpose overlock thread, polyester thread, embroidery and darning thread	Stitch length: 2.5 Cutting width: 2 Differential: N-1.5 (knits), 0.7-N (wovens)
				B	Lower looper: woolly nylon or similar decorative thread Needle: all-purpose overlock thread, polyester thread	
5	3 thread narrow seam 		3-5 mm needle C	A	Loopers/needle: all-purpose overlock thread, polyester and rayon threads	Stitch length: 1.0-1.8 Cutting width: 1-2 Differential: 0.7-N
				B	Loopers: woolly nylon Needle: all-purpose overlock thread, polyester thread	
6	2 thread roll hem 		1-3 mm needle C	A	Lower looper/needle: all-purpose overlock thread, embroidery or darning thread, rayon thread	Stitch length: 1.0-1.8 Cutting width: 1-2 Differential: 0.7-N
				B	Loopers: woolly nylon Needle: all-purpose overlock thread	
7	3 thread roll hem 		1-3 mm needle C	C	Upper looper: all-purpose overlock thread, woolly nylon, embroidery, darning or rayon thread Lower looper: all-purpose overlock thread, embroidery, darning or rayon thread Needle: all-purpose overlock thread, embroidery or darning thread, rayon thread	Stitch length: 1.0-1.8 Cutting width: 1-2 Differential: 0.7-N
8	3 thread flatlock 		3-5 mm needle C 5-7 mm needle L	D	Upper looper: all-purpose overlock thread, polyester thread, woolly nylon or similar decorative or rayon thread Lower looper, needle: all-purpose overlock thread, polyester thread	Stitch length: min. 2.5 Cutting width: 2 Differential: N
9	2 thread flatlock 		3-5 mm needle C 5-7 mm needle L	E	Lower looper: all-purpose overlock thread, polyester thread, woolly nylon or similar decorative or rayon thread Needle: all purpose overlock thread, polyester thread	Stitch length: min. 2.5 Cutting width: 2 Differential: N

Applications	Exemples	Stitch
<ul style="list-style-type: none"> ■ Durable stretch seams in jerseys and knits in cotton, wool, synthetic and blended fibres and for machine and hand knits. ■ Ideal for seams in fine to medium weight cotton, viscose, satin or synthetic fibres, e.g. batiste, crepe-de-chine, poplin, satin, etc. 	Sweatshirts, running suits, jersey and knitted garments, children's clothing, light outer wear, home dec.	
<ul style="list-style-type: none"> ■ Very elastic seams in stretchy fabrics such as Lycra. 	Swimwear, gymwear, sportswear	
<ul style="list-style-type: none"> ■ Neatening edges of seam allowances, hems and facings. Suitable for all types of fabric. ■ Stretchy seams in fine knits. ■ Decorative and quickly sewn edges. ■ Decorative seams in woven or fleecy fabrics or firm knits. 	Neatening and sewing seams in clothing and home dec articles. Seams in T-shirts, baby and children's wear and all garments such as coats, jackets pullovers as well as tablecloths, table mats, napkins, cushions and curtains.	
<ul style="list-style-type: none"> ■ Neatening edges on seam allowances, hems and facings. Suitable for all fabrics. ■ Double sided edging. ■ Decorative seams on firm wovens, fleecy fabrics or firm knits. 	Neatening seams in clothing and home dec articles. Decorative finish on clothing such as coats, jackets and pullovers as well as tablecloths, table mats, napkins, cushions and curtains.	
<ul style="list-style-type: none"> ■ Narrow seams in the finest of silks, cotton or synthetic jersey. Particularly suitable for lingerie or lace inserts and fine pintucks. 	Lingerie, underwear, light outerwear, e.g. blouses, summer dresses, children's wear.	
<ul style="list-style-type: none"> ■ Fine edge finish on sheer and lightweight woven fabrics or jerseys. Suitable for pintucks or lace insertion. 	Lingerie, underwear, scarves, handkerchiefs. Light outer wear, evening wear, home dec.	
<ul style="list-style-type: none"> ■ Quickly sewn delicate and fine edging for all fine or sheer fabrics. 	Lingerie, underwear, scarves. Light outerwear, evening wear, home dec	
<ul style="list-style-type: none"> ■ Flat decorative seams in knit or woven fabrics. Suitable for patchwork. 	Home dec: cushions, bedspreads Clothing: jackets, coats, pullovers	
<ul style="list-style-type: none"> ■ Decorative flat seam with slight stretch. Suitable for knits or woven fabrics. Ideal for patchwork. 	Clothing: sportswear, gymwear, swimwear, fleece pullovers, jackets, coats. Home dec: cushions, bed covers etc.	

Threading symbols

The stitch display provides all the information you need about stitches and threading.

Symbols:

Yellow line = insert needle **L** and thread

Green line = insert needle **C** and thread

Brown line = insert needle **R** and thread

Blue dot = thread the upper looper through the blue guides

Red dot = thread the lower looper through the red guides

Purple dot = thread the lower looper through the purple guides

Small black dot = do not thread needle, remove needle

■ Attach the upper looper converter (upper looper is not threaded)

▲ Move stitch selection lever to overlock

▽ Move stitch selection lever to roll hem

⤴ Raise the upper knife and upper knife arm

📄 Attach the cover stitch extension plate

⤵ Lower the wiper and finger guard

⚙️ Press in wiper activating lever











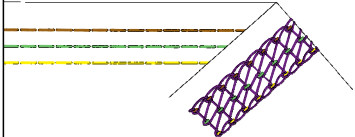

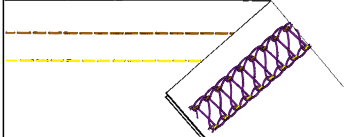
Note:

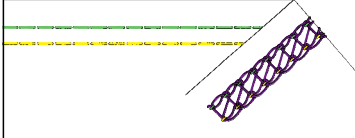
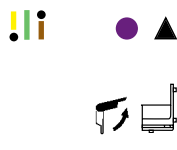
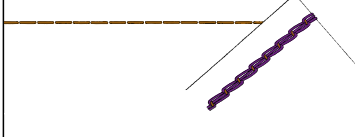

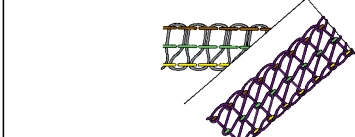

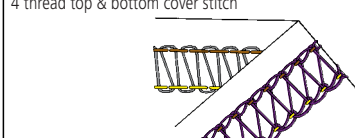

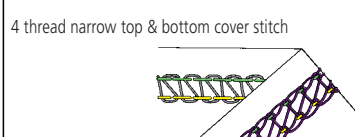
The positions **A**, **C**, **D** and **E** are for overlock stitches using standard overlock thread.

The stitches on Position **B** are the same as position **A** but with pre-set tensions for woolly nylon or a similar decorative thread in the loopers.

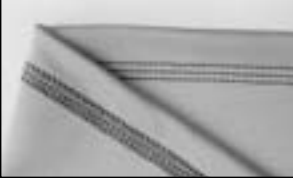
Position **F** is pre-set for cover stitch, **G** for chain stitch using all-purpose overlock thread and **H** for top & bottom cover stitch. The machine must be converted (see page 60).

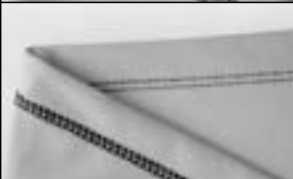
Stitch Chart

No.	Stitch	Symbols	Stitch	Pos.	Thread	Basic settings
10	4 thread cover stitch 		5 mm needles R, C and L	F	Lower looper: all-purpose overlock thread, polyester thread, woolly nylon or similar decorative thread Needles: all-purpose overlock thread, polyester thread	Stitch length: 3-4 Differential: N
11	3 thread cover stitch 		5mm needles R and L	F	Lower looper: all-purpose overlock thread, polyester thread, woolly nylon or similar decorative thread Needles: all-purpose overlock thread, polyester thread	Stitch length: 3 Differential: N
12	3 thread narrow cover stitch 		2.5 mm needles C and L or C and R	F	Lower looper: all-purpose overlock thread, polyester thread, woolly nylon or similar decorative thread Needles: all-purpose overlock thread, polyester thread	Stitch length: 3 Differential: N
13	Chain stitch 		Needle R	G	Lower looper: all-purpose overlock thread, polyester thread, woolly nylon or similar decorative thread Needle: all-purpose overlock thread, polyester thread	Stitch length: 2.5 Differential: N
14	5 thread top & bottom cover stitch 		5 mm needles L, C and R	H	Lower looper: all-purpose overlock thread, polyester thread, woolly nylon or similar decorative thread Wiper thread: all-purpose overlock thread, polyester thread, woolly nylon or similar decorative thread Needles: all-purpose overlock thread, polyester thread	Stitch length: 3-4 Differential: N
15	4 thread top & bottom cover stitch 		5 mm needles L and R	H	Lower looper: all-purpose overlock thread, polyester thread, woolly nylon or similar decorative thread Wiper thread: all-purpose overlock thread, polyester thread, woolly nylon or similar decorative thread Needles: all-purpose overlock thread, polyester thread	Stitch length: 3-4 Differential: N
16	4 thread narrow top & bottom cover stitch 		2.5 mm needles C and L	H	Lower looper: all-purpose overlock thread, polyester thread, woolly nylon or similar decorative thread Wiper thread: all-purpose overlock thread, polyester thread, woolly nylon or similar decorative thread Needles: all-purpose overlock thread, polyester thread	Stitch length: 3-4 Differential: N

Applications	Examples	Stitch
<ul style="list-style-type: none"> ■ The perfect flat hem for all stretch fabrics. ■ Ideal for sewing and finishing with elastic or for binding edges in stretch fabrics. ■ Decorative topstitch seams which can also be sewn with decorative thread (wrong side of stitch visible). 	T-shirts, swim and gymwear, garments made from knit and jerseys, underwear, lingerie, children's clothing, pullovers, sweatshirts.	
<ul style="list-style-type: none"> ■ The perfect flat hem for all stretch fabrics. ■ Ideal for sewing and finishing with elastic or for binding edges in stretch fabrics. ■ Decorative topstitch seams which can also be sewn with decorative thread (wrong side of stitch visible). 	T-shirts, swim and gymwear, garments made from knit and jerseys, underwear, lingerie, children's clothing, pullovers, sweatshirts.	
<ul style="list-style-type: none"> ■ The perfect flat hem for all stretch fabrics. ■ Ideal for sewing and finishing with elastic or for binding edges in stretch fabrics. ■ Decorative topstitch seams which can also be sewn with decorative thread (wrong side of stitch visible). 	T-shirts, swim and gymwear, garments made from knit and jerseys, underwear, lingerie, children's clothing, pullovers, sweatshirts.	
<ul style="list-style-type: none"> ■ Chain stitch has limited elasticity and is ideal for firm, thicker fabrics. ■ Use to stabilize seams and for binding. ■ Ideal as decorative top stitching. 	Thick or heavy-weight woven fabrics and knits with limited stretch. Denim, corduroy, polar fleece. Sweaters, thick knits, towelling, children's clothing, home dec, patchwork.	
<ul style="list-style-type: none"> ■ The perfect flat seam or hem for all stretch fabrics. ■ Ideal for construction sewing and finishing with elastic or for binding edges in stretch fabrics. ■ Decorative topstitch seams which can also be sewn with decorative thread. 	T-shirts, swim and gymwear, garments made from knit and jerseys, underwear, lingerie, children's clothing, pullovers, sweatshirts and sportswear in general.	
<ul style="list-style-type: none"> ■ The perfect flat seam or hem for all stretch fabrics. ■ Ideal for construction sewing and finishing with elastic or for binding edges in stretch fabrics. ■ Decorative topstitch seams which can also be sewn with decorative thread. 	T-shirts, swim and gymwear, garments made from knit and jerseys, underwear, lingerie, children's clothing, pullovers, sweatshirts and sportswear in general.	
<ul style="list-style-type: none"> ■ The perfect flat seam or hem for all stretch fabrics. ■ Ideal for construction sewing and finishing with elastic or for binding edges in stretch fabrics. ■ Decorative topstitch seams which can also be sewn with decorative thread. 	T-shirts, swim and gymwear, garments made from knit and jerseys, underwear, lingerie, children's clothing, pullovers, sweatshirts and sportswear in general.	

Threading symbols:

The stitch display provides all the information you need about stitches and threading.

Symbols:

Yellow line = insert needle **L** and thread

Green line = insert needle **C** and thread

Brown line = insert needle **R** and thread

Blue dot = thread the upper looper through the blue guides

Red dot = thread the lower looper through the red guides

Purple dot = thread the lower looper through the purple guides

Small black dot = do not thread needle, remove needle

■ Attach the upper looper converter (upper looper is not threaded)

▲ Move stitch selection lever to overlock

▽ Move stitch selection lever to roll hem

— Raise the upper knife and upper knife arm

 Attach the cover stitch extension plate

 Lower the wiper and finger guard

 Press in wiper activating lever

Note:

The positions **A, C, D** and **E** are adjusted for overlock stitches using standard overlock thread.

The stitches on **Position B** are the same as **position A** but with pre-set tensions for woolly nylon or a similar decorative thread in the loopers.

Position F is pre-set for cover stitch, **G** for chain stitch using all-purpose overlock thread and **H** for top & bottom cover stitch.

Threading the machine for overlock and cover/chain stitch

General threading instructions

Thread the machine in the following sequence.

Overlock stitches:

1. Upper looper (blue markings)
2. Lower looper (red markings)
3. Needle **C** (green markings)
4. Needle **L** (yellow markings)

Tip:

When threading for the first time, use coloured threads to match the threading codes, i.e. blue, red, green and yellow for 4-thread overlock, so that when you test sew, you can see exactly how the stitch is formed.

Cover stitch/top & bottom cover stitch:

1. Lower looper (purple markings)
2. Needle **R** (brown markings)
3. Needle **C** (green markings)
4. Needle **L** (yellow markings)
5. Wiper thread (grey markings)

Tip:

When threading for the first time, use the same coloured threads as the markings, i.e. purple, brown, green and yellow) for 4 thread cover stitch, so that you can see exactly how it is formed.

Chain stitch:

1. Lower looper (purple markings)
2. Needle **R** (brown markings)

Your BERNINA overlocker is equipped with practical threading aids:

- Stitch display with threading information
- Coloured threading diagram inside the looper cover
- Colour coded threading paths
- Lay-in thread guides
- Threading accessories in the looper cover

30

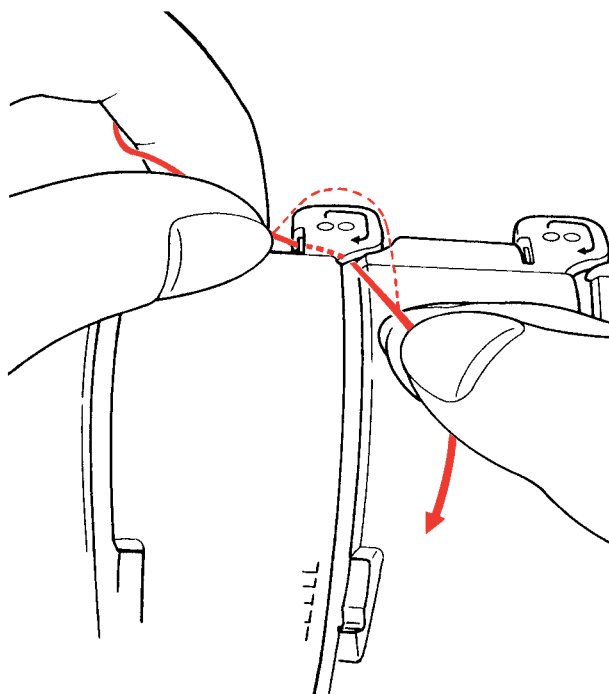

Preparation

- Raise the support rod fully
- Raise the needles (Needle stop)
- Raise the presser foot. The tensions release automatically.
- Swing foot out.
- Open the looper cover.
- Raise the upper knife (if wanted)

First thread guide on the machine

Thread the first guides on the top of the machine as follows: Holding the thread with both hands slip it into the appropriate guide from back left to front right in the direction of the arrow and pull gently to check that it is lying correctly.

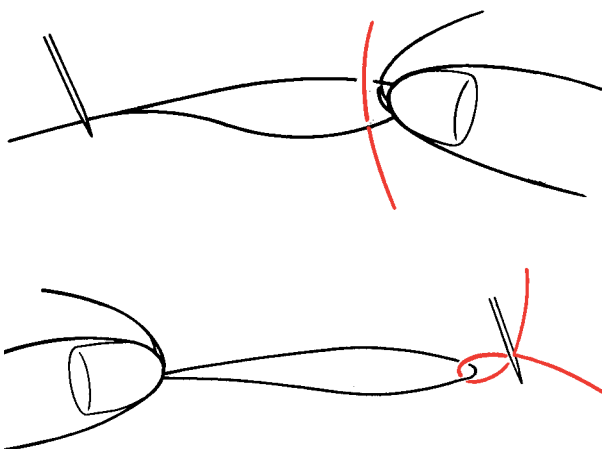

Needle/looper threader

Insert the thread into the threader. Push the rigid end of the threader through the needle or looper eye and pull it completely through.

Upper looper (blue markings)

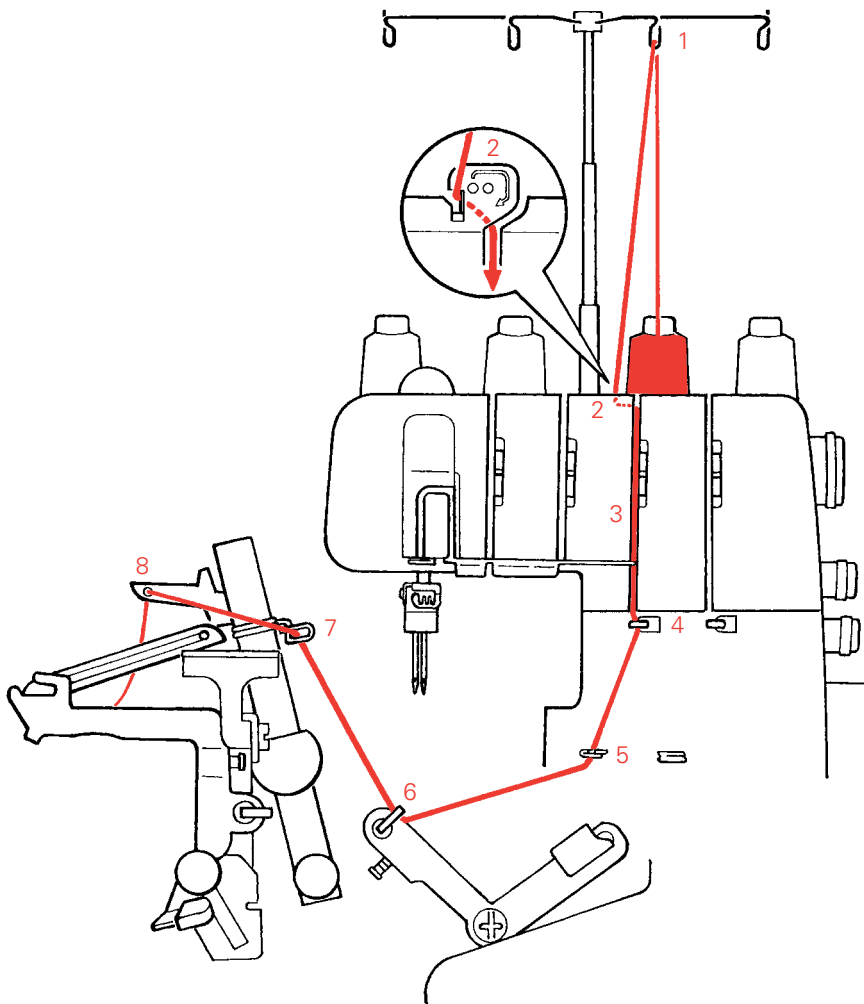

Place the spool on the spool pin as illustrated.

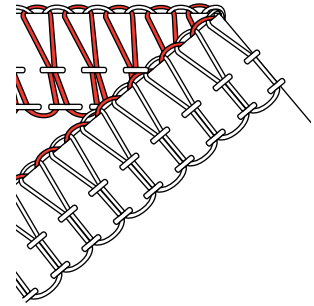

1. Bring the thread up from the spool and lay it from the back to the front into the guide.
2. Thread the first machine guide.
3. Slip the thread through the groove.
- 4., 5., 6., 7. Thread the guides.
8. Thread the looper eye and lay the thread to the left under the presser foot.

Note:
Do not thread the upper looper when using the upper looper converter.

Overlock threading

Lower looper (red markings)

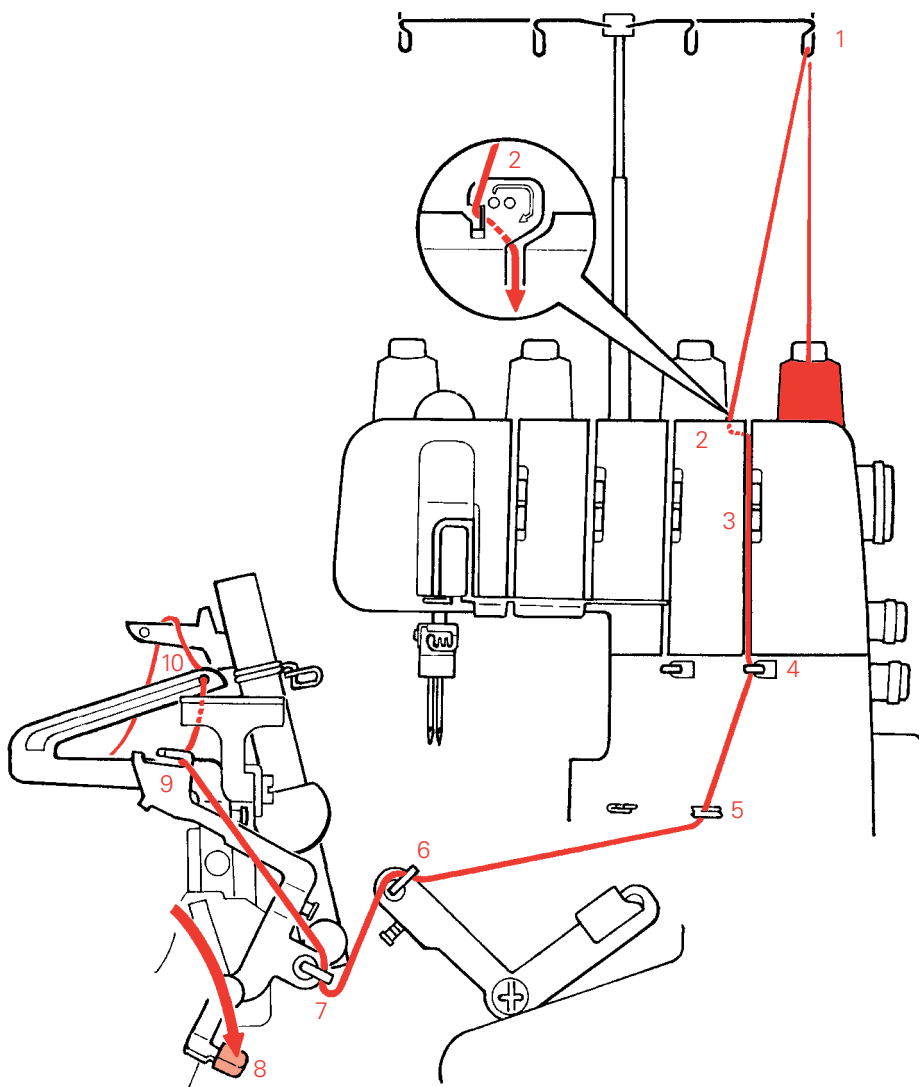

Place the spool on the spool pin as illustrated.

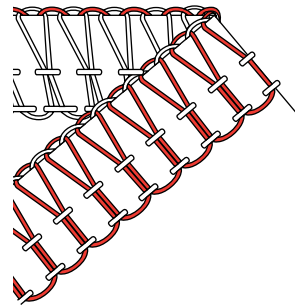

1. Bring the thread up from the spool and lay it from the back to the front into the guide.
2. Thread the first machine guide.
3. Slip the thread through the groove.
- 4., 5., 6., 7. Thread the guides.
8. Press the lever on the auto-threader down.
9. Thread the slit on the threader. Push the auto-threader lever up to return it to its normal position.
10. Thread the lower looper eye and lay the thread to the left under the presser foot.

Note:
If the lower looper has to be re-threaded, cut off both needle threads and remove surplus thread from below. First thread the looper and then re-thread the needles.

Needle C (green markings)

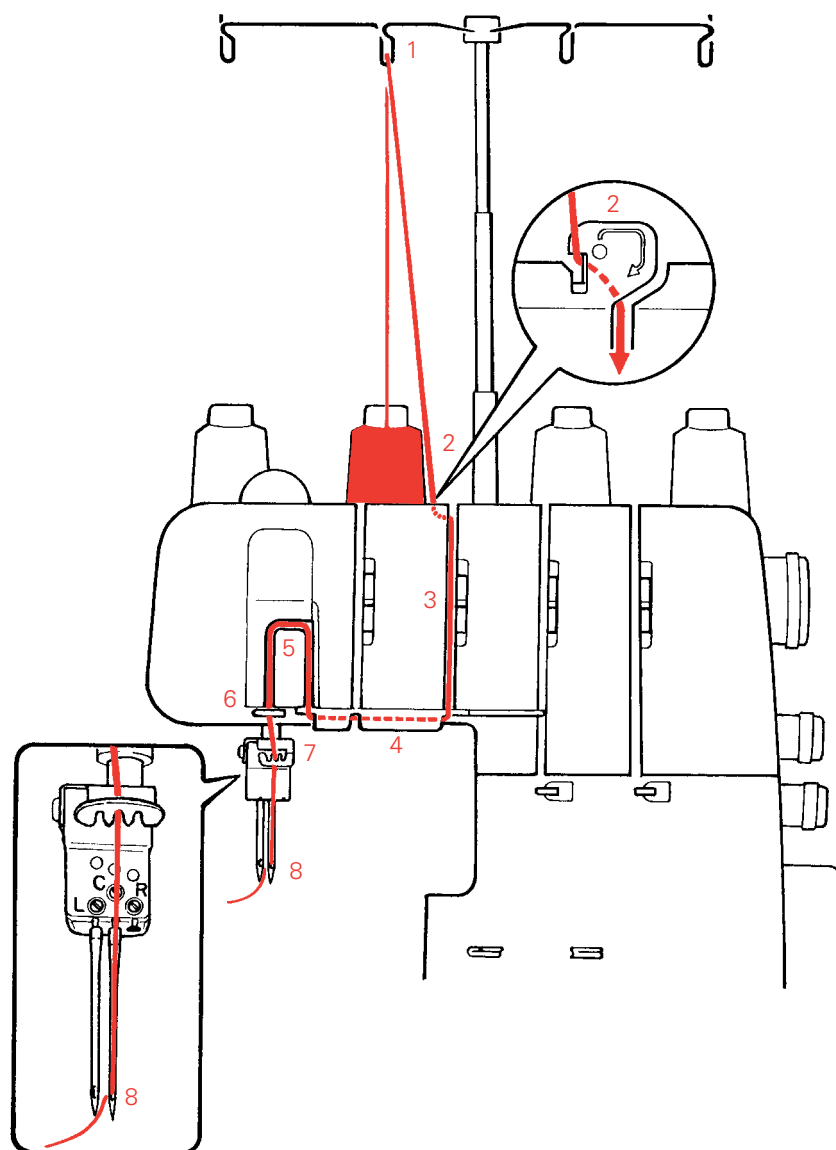

Place the spool on the spool pin as illustrated.

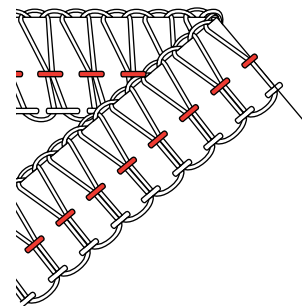

1. Bring the thread up from the spool and lay it from the back to the front into the guide.
2. Thread the first machine guide.
3. Slip the thread through the groove.
- 4., 5., 6. Take the thread under the thread guide plate, through the take up and into the guide.
7. Thread the guide on the needle clamp.
8. Thread needle C from front to back and lay the thread to the left under the foot.

Overlock threading

Needle L (yellow markings)

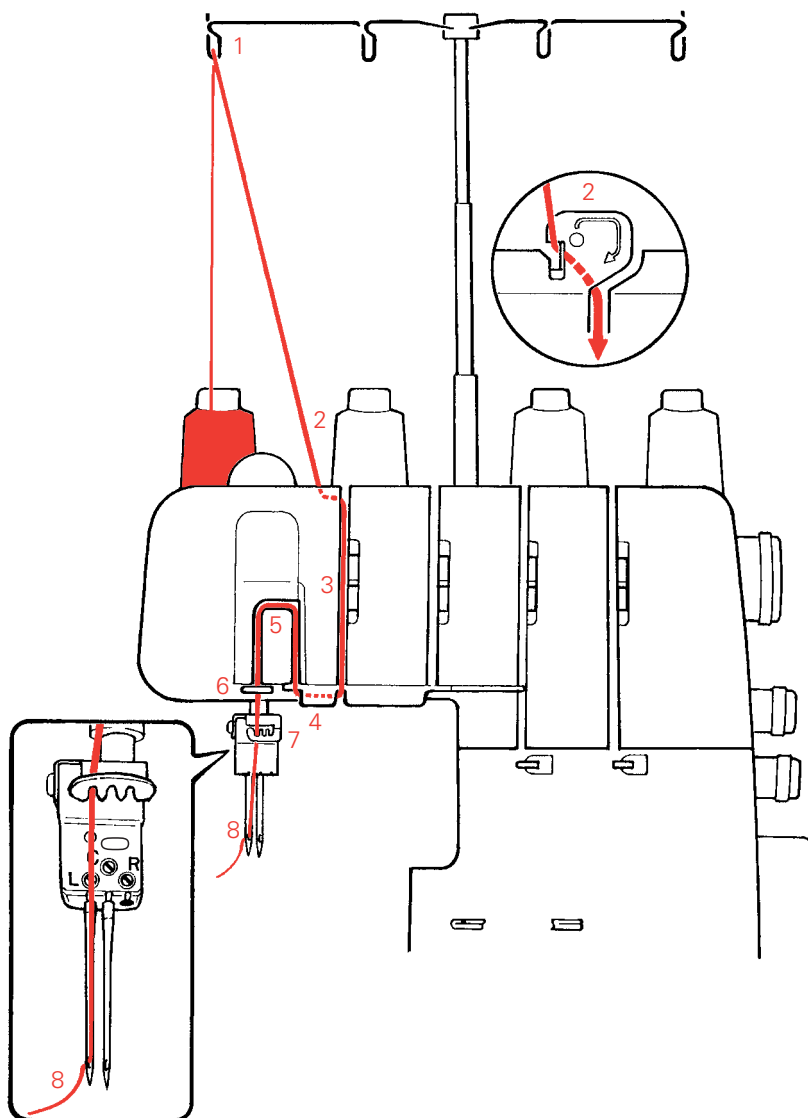

Place the spool on the spool pin as illustrated.

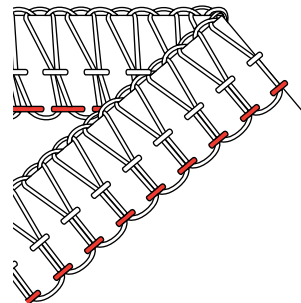

1. Bring the thread up from the spool and lay it from the back to the front into the guide.
2. Thread the first thread guide.
3. Slip the thread through the groove.
- 4., 5., 6. Take the thread under the thread guide plate, through the take up and into the guide.
7. Thread guide on the needle clamp.
8. Thread needle **L** from front to back and lay the thread to the left under the foot.

After threading

When threading is complete, lower upper knife (if raised), close the looper cover (place waste collector in position).

Re-threading or changing threads

If spools are empty or you want to change the thread, it is not necessary to re-thread the machine. Simply cut off the threads above the cones or spools, replace them and knot new

thread on to the existing thread. Cut the threads off at the needles. Raise the presser foot, pull the threads through and re-thread the needles. Pull the looper threads through using the

existing thread chain. Some thick decorative threads cannot be pulled through the looper eyes. Lower the presser foot. Select the stitch of your choice and test sew.

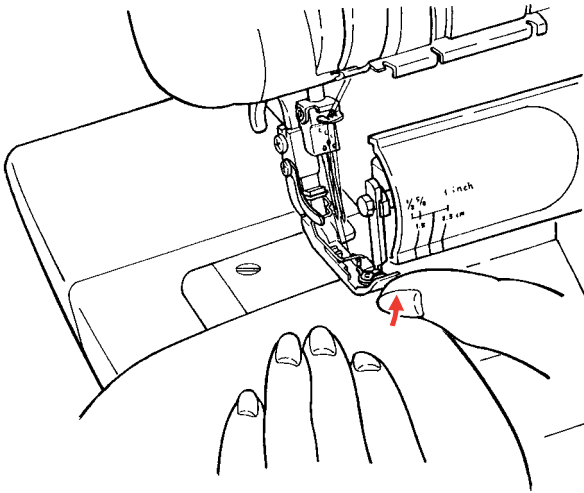

After threading select the stitch of your choice (stitch selection dial) and test sew.

Seam begin, seam end, thread cutter

Raise the tip of the presser foot with your thumb and position the fabric just under the foot. Let go of the foot and start to sew. The fabric will be taken up automatically.

At the end of the seam, continue sewing a 8 cm (3") long thread chain (1).

Holding the fabric in your left hand, pull the thread chain over the thread cutter (2).

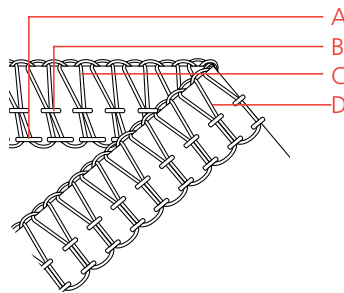
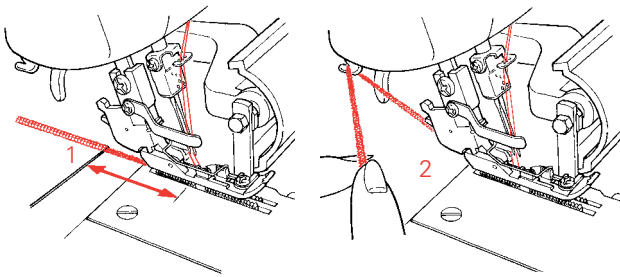

Fine tuning

Compare your sewing test with the stitch formations on the waste collector or diagram inside the looper cover.

Example: 4 thread overlock

- A Needle L thread (yellow)
- B Needle C thread (green)
- C Upper looper thread (blue)
- D Lower looper thread (red)

The upper looper thread lies on the upper side of the fabric and the lower looper thread lies on the underside of the fabric. The loops formed by both threads meet exactly on the edge of the fabric.

Needle C thread forms a stretchy safety seam in the centre of the stitch. Needle L thread anchors both looper threads.

Stitch formations which are not perfect can be corrected with fine tuning (3).

To increase the tension, move the fine tuning lever up. To reduce the tension, move the lever down.

- A Needle L fine tuning (yellow)
- B Needle C fine tuning (green)
- C Upper looper fine tuning (blue)
- D Lower looper fine tuning (red)

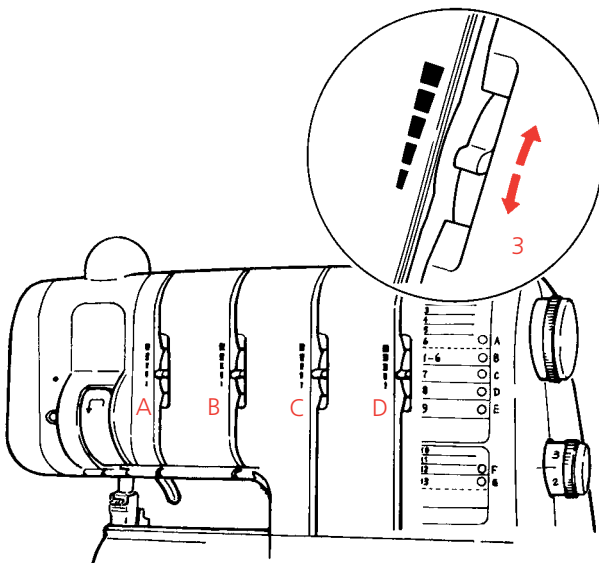

Deco guide

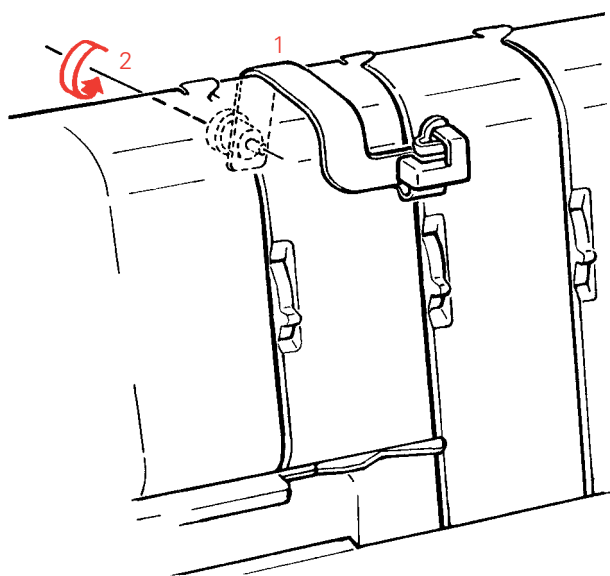

The deco guide (in the accessory bag) is specially designed for sewing wide seams and edges with decorative threads (see section Threads/Decorative thread page 23).

Position the guide over the top of the machine over one of the thread slits (1) and tighten screw (2).

Take the thread through the deco guide without threading the first machine guide or tension slit.

3/4 thread overlock with medium to heavy weight thread: position the guide over the upper looper tension.

2 thread overlock with heavy thread: position the guide over the lower looper tension.

3 thread overlock with fine rayon embroidery thread, e.g. Rayon No. 40: take threads through the deco guide to the needles. Test sew.

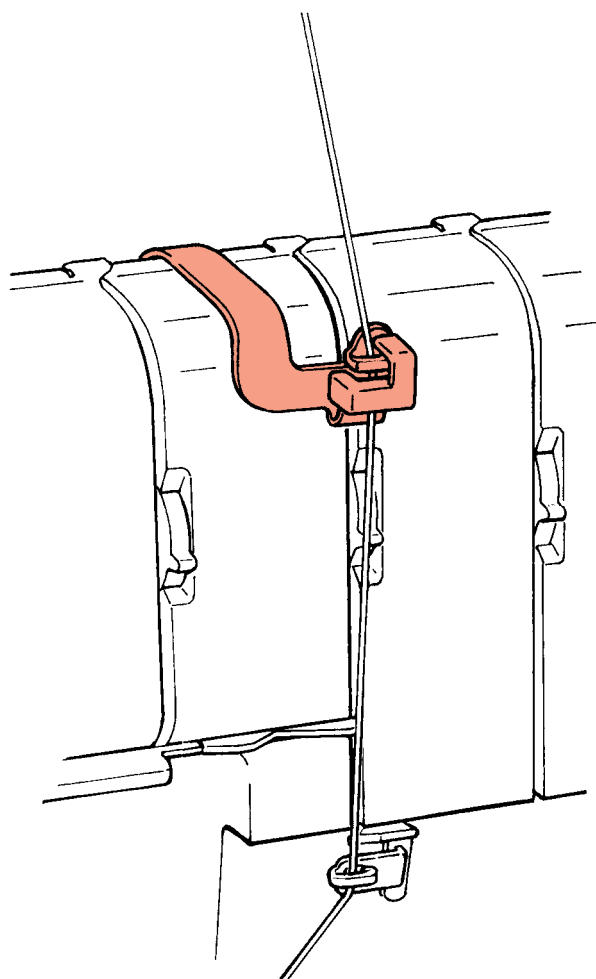

Fine tuning for 3/4 thread overlock and 3 thread narrow seam:

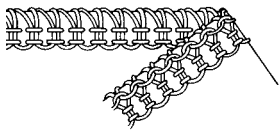

The loops are formed on the underside:
 Increase the upper looper tension (blue).
 Reduce the lower looper tension (red).

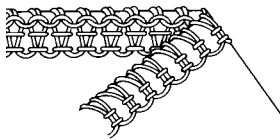

The loops are formed on the upper side:
 Increase the lower looper tension (red).
 Reduce the upper looper tension (blue).

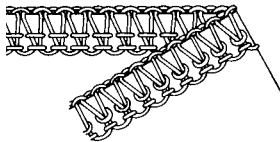

Needle C thread forms loops on the underside:
 Increase the needle tension (green).

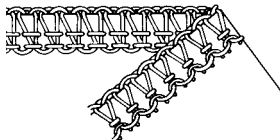

Needle L thread forms loops on the underside:
 Increase the needle tension (yellow).
 Reduce the lower looper tension (red).

Fine tuning for 3 thread flatlock

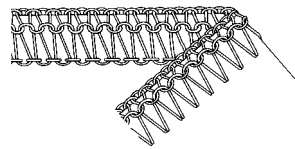

The loops are formed on the upper side:
 Reduce the upper looper tension (blue).
 Increase the needle (yellow or green) or increase the lower looper tension (red).

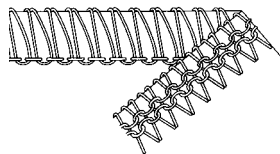

The loops are formed on the underside.
 Increase the lower looper (red) or upper looper tension (blue).
 Reduce the needle tension (yellow or green). The deco guide could be used.

Fine tuning for 2 thread flatlock

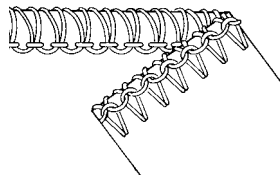

The loops are formed on the underside:
 Increase the lower looper tension (red).
 Reduce the needle tension (yellow or green). The deco guide could be used.

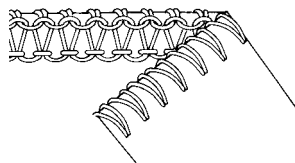

The loops are formed on the upper side:
 Reduce the lower looper tension (red).
 Increase the needle tension (yellow or green).

Fine tuning for 3 thread super stretch, 2 thread wrapped overlock and 2 thread roll hem

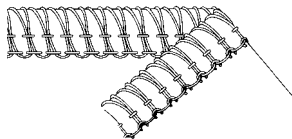

The needle thread forms loops on the underside.
 Reduce the lower looper tension (red).

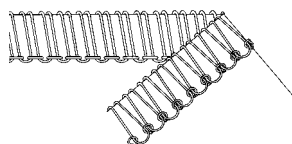

Tip:
 The elasticity of the 3 thread super stretch stitch can be increased by reducing the needle tensions or shortening the stitch length, depending on the fabric and application.

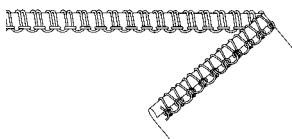

Fine tuning for 3 thread roll hem

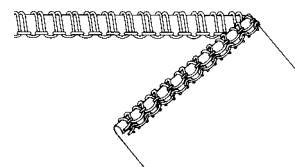

The loops do not meet at the line of the needle thread on the underside:
 Increase the lower looper (red) or needle thread (green) tension.
 Reduce the upper looper thread tension (blue).

Tip:
 Use woolly nylon in the upper looper only.

Cover/chain stitch functions and general operating instructions

Cover Stitch

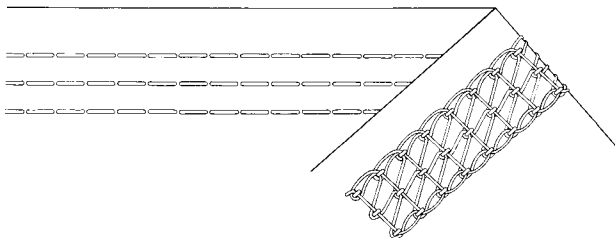

The 5 mm wide cover stitch is formed with two or three needle threads and one looper thread. The needle threads appear as two or three parallel lines on the right side of the fabric. The 2.5 mm cover stitch is sewn with two needle threads and one looper thread. The looper thread covers and neatens the seam on the wrong side. The elasticity of cover stitch makes it ideal for all stretch fabrics. The cover stitch is sewn in the fabric and not on the fabric edge, i.e. the fabric is not cut. The upper knife and upper knife arm are raised. The cover stitch gives a truly professional finish to all your home sewing. It is perfect for hems, top stitching, flat joining seams and edging with elastic and bindings.

Stitch selection dial / position F

To select cover stitch turn the stitch selection dial to position F.

The sewing speed on position F is automatically reduced from 1500 s.p.m. to max. 800 s.p.m.

The needle stop is automatically set to down. The cover stitch formation ends with the needle inserted in the fabric.

Note:

When sewing is completed or interrupted, the needles stay in the fabric. This is ideal for positioning your work while sewing. To remove your work, raise the needles by turning the handwheel backwards, i.e. away from you in a clockwise direction.

Chain stitch

Stitch selection dial / position G

To select chain stitch turn the stitch selection dial to position G.

The sewing speed on position G is automatically reduced from 1500 s.p.m. to max. 800 s.p.m.

The needle stop is automatically set to down. The chain stitch formation ends with the needle inserted in the fabric.

Note:

When sewing is completed or interrupted, the needles stay in the fabric. This is ideal for positioning your work while sewing. To remove your work, raise the needles by turning the handwheel backwards, i.e. away from you in a clockwise direction.

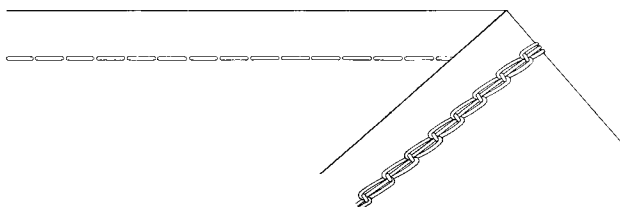
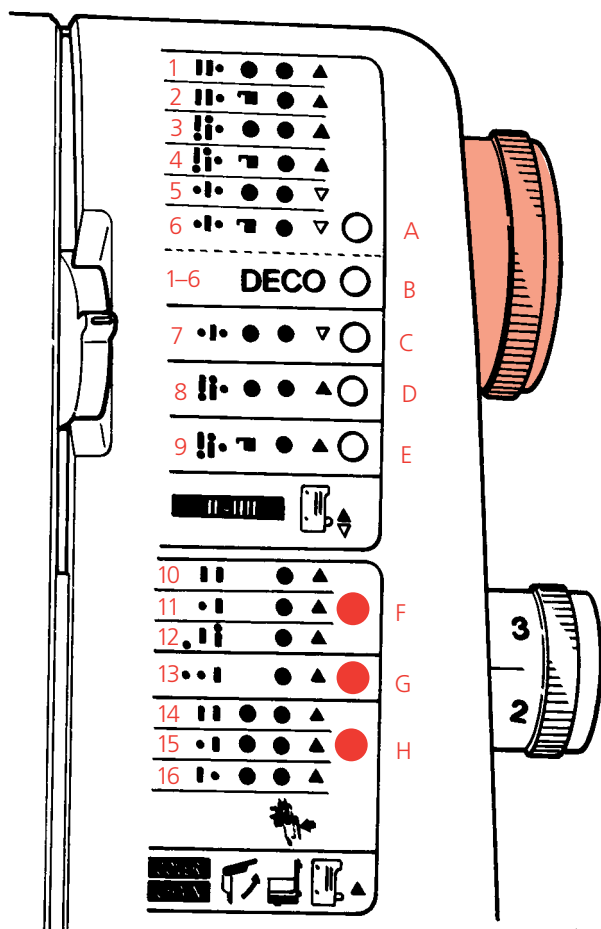

Top & bottom cover stitch

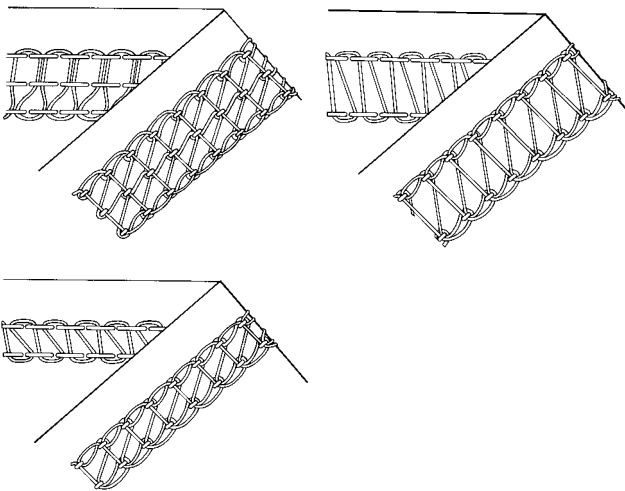

The 5 mm wide top & bottom cover stitch is formed with two or three needle threads, a wiper thread and one looper thread. The needle threads appear as two or three parallel lines on the right side of the fabric. The 2.5 mm top & bottom cover stitch is sewn with two needle threads, one wiper thread and one looper thread. The wiper thread covers the seam on the right side, while the looper thread covers and neatens the seam on the wrong side. The elasticity of cover stitch makes it ideal for all stretch fabrics. The cover stitch is sewn in the fabric and not on the fabric edge, i.e. the fabric is not cut. The upper knife and upper knife arm are raised. The cover stitch gives a truly professional finish to all your home sewing. It is perfect for hems, top stitching, flat joining seams and edging with elastic and bindings.

Stitch selection dial / position H

39

To select cover stitch turn the stitch selection dial to position H.

The sewing speed on position is automatically reduced from 1500 s.p.m. to max. 500 s.p.m.

The needle stop is automatically set to down. The cover stitch formation ends with the needle inserted in the fabric.

Note:

When sewing is completed or interrupted, the needles stay in the fabric. This is ideal for positioning your work while sewing. To remove your work, raise the needles by turning the handwheel backwards, i.e. away from you in a clockwise direction.

WARNING: If sewing in top & bottom cover stitch mode, when lifting the presser foot to its highest position (2), do not use any force.

Looper conversion arm

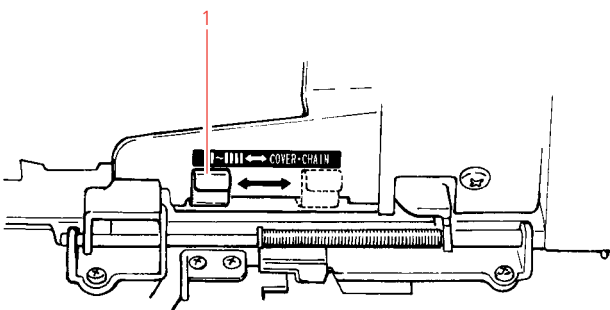

- Lower the needle clamp, press Needle stop. The loopers are automatically lowered.
- Open the looper cover.
- The looper conversion arm can now be moved from overlock to cover/chain stitch or from cover/chain stitch to overlock (1).

When the conversion arm is switched from overlock to cover/chain stitch, the upper looper is released and the movement of the lower looper becomes elliptic.

When the conversion arm is switched from cover/chain stitch to overlock, the upper looper is reinstated and the lower looper moves left and right.

Mechanical safety

In addition to the electronic safety features (page 14) your machine is equipped with mechanical safety features.

The looper cover can only be closed when:

- the position of the conversion arm corresponds to the cover/chain stitch extension plate or the knife guard (overlock)
- the upper knife is in the raised position when the cover/chain stitch extension plate is attached.

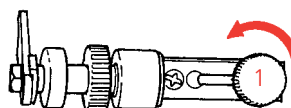

Upper knife arm

The knives are not used for cover and chain stitch and the upper knife arm is raised to provide additional space to the right of the needle.

Raising the upper knife arm:

- (looper cover open)
- Raise the upper knife.
- Loosen the screw (1).
- Press the screw to the left (2), push the arm up (3) and the screw engages on the right (4).
- Tighten the screw.

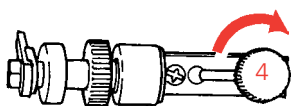
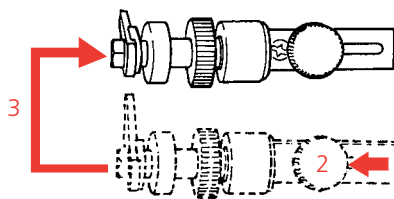

Lowering the upper knife arm:

- (looper cover open)
- Loosen the screw and press to the left (5).
- Push the arm down (6) and push the screw to the right (7).
- Tighten the screw.
- Lower the upper knife, making sure it engages. (Close looper cover.)

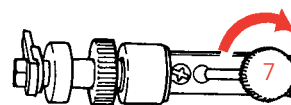
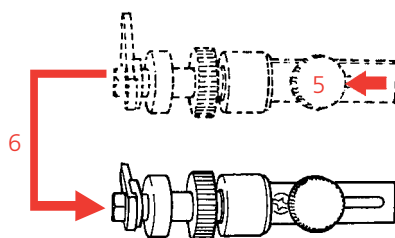

Note:

See page 20 for raising and lowering the upper knife.

BERNINA⁺

© Copyright 1999 by BERNINA International AG, Steckborn

99/6 GB

Knife guard/cover and chain stitch extension plate

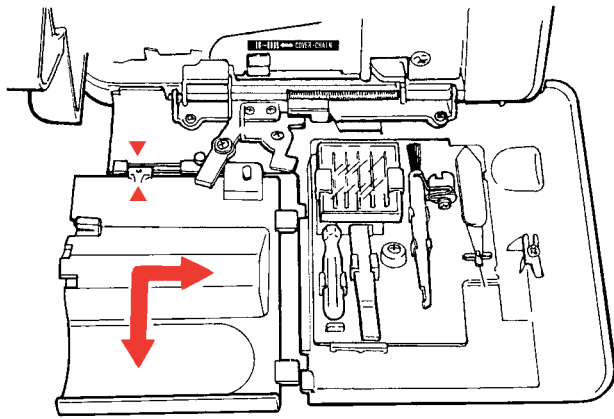

When the machine is converted to cover/chain stitch, the knife guard in the looper cover is replaced by the cover stitch extension plate. The extension plate covers the released upper looper and extends the stitch plate to the right of the presser foot.

To replace:

Open the looper cover. Remove the knife guard by pulling gently to the left. To attach the extension plate, hold it at a slight angle to the looper cover, position (1), hold both parts parallel and push the plate to the right until it clicks into place.

Note:

The looper cover will not close and the machine will not sew when:

- the position of the conversion arm does not correspond to the extension plate (cover/chain stitch) or knife guard (overlock)
- the upper knife is not in the raised position when the cover stitch extension plate is attached
- the selection lever is in roll hem position.

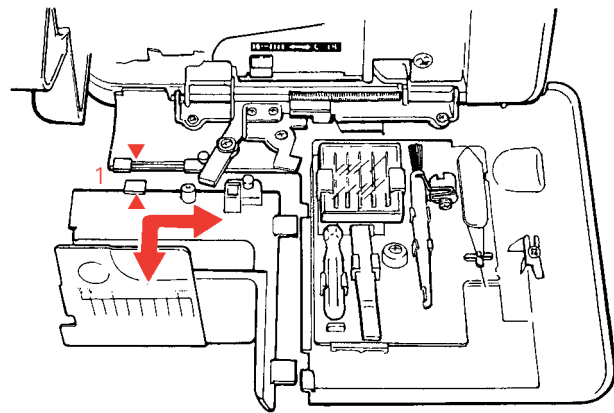

Threading 4 thread cover stitch (position F)

Cover stitch looper (purple markings)

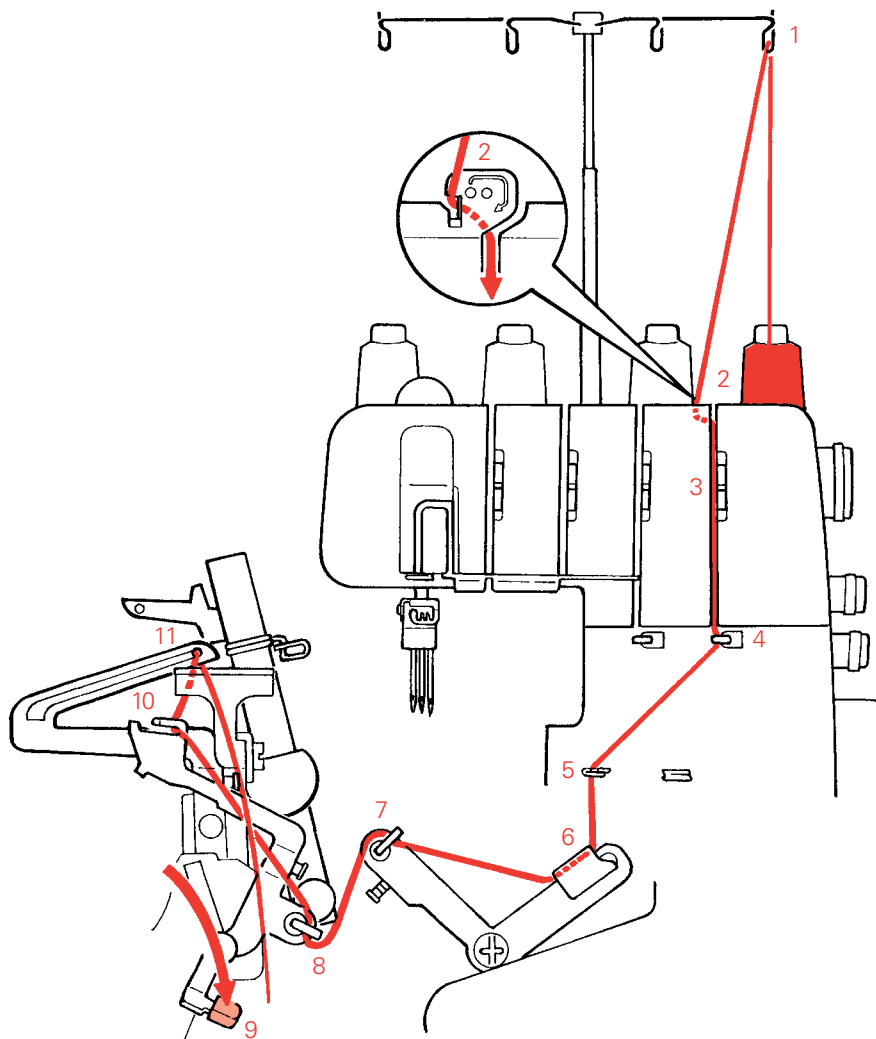

Place the spool on the spool pin as illustrated.

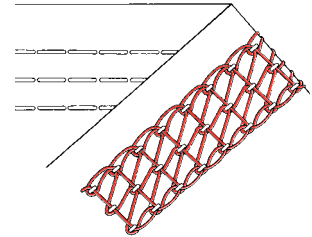

1. Bring the thread up from the spool and lay it from the back to the front into the guide.
2. Thread the first guide.
3. Take the thread through the groove.
- 4., 5., 6., 7., 8., Thread guides
9. Press the lever of the auto-threader down.
10. Thread the slit of the threader. Push the auto-threader lever up and it will return to its normal position.
11. Thread the looper eye. Leave the thread end (8 cm or 3") hanging in the machine.

Cover stitch needle R (brown markings)

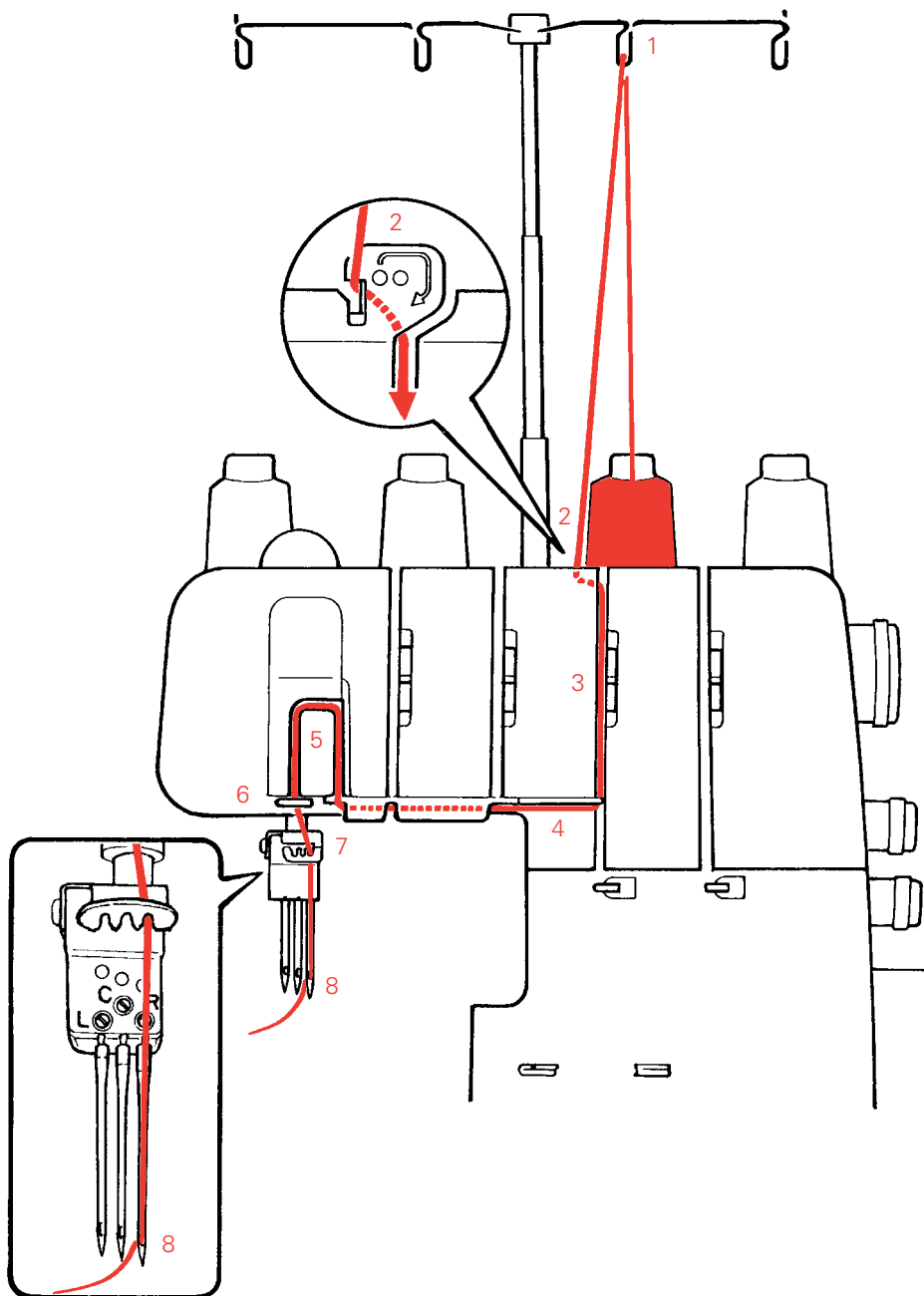

Place the spool on the spool pin as illustrated.

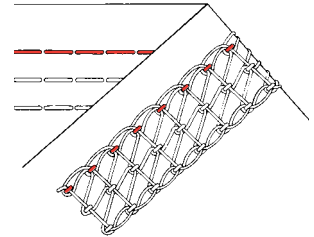

1. Bring the thread up from the spool and lay it from the back to the front into the guide.
2. Thread the first guide.
3. Take the thread through the groove.
- 4., 5., 6. Take the thread under the thread guide plate, through the take up and into the guide.
7. Thread guide on the needle clamp.
8. Thread the needle R from front to back and lay the thread to the left under the foot.

Threading 4-thread cover stitch

Cover stitch needle C (green markings)

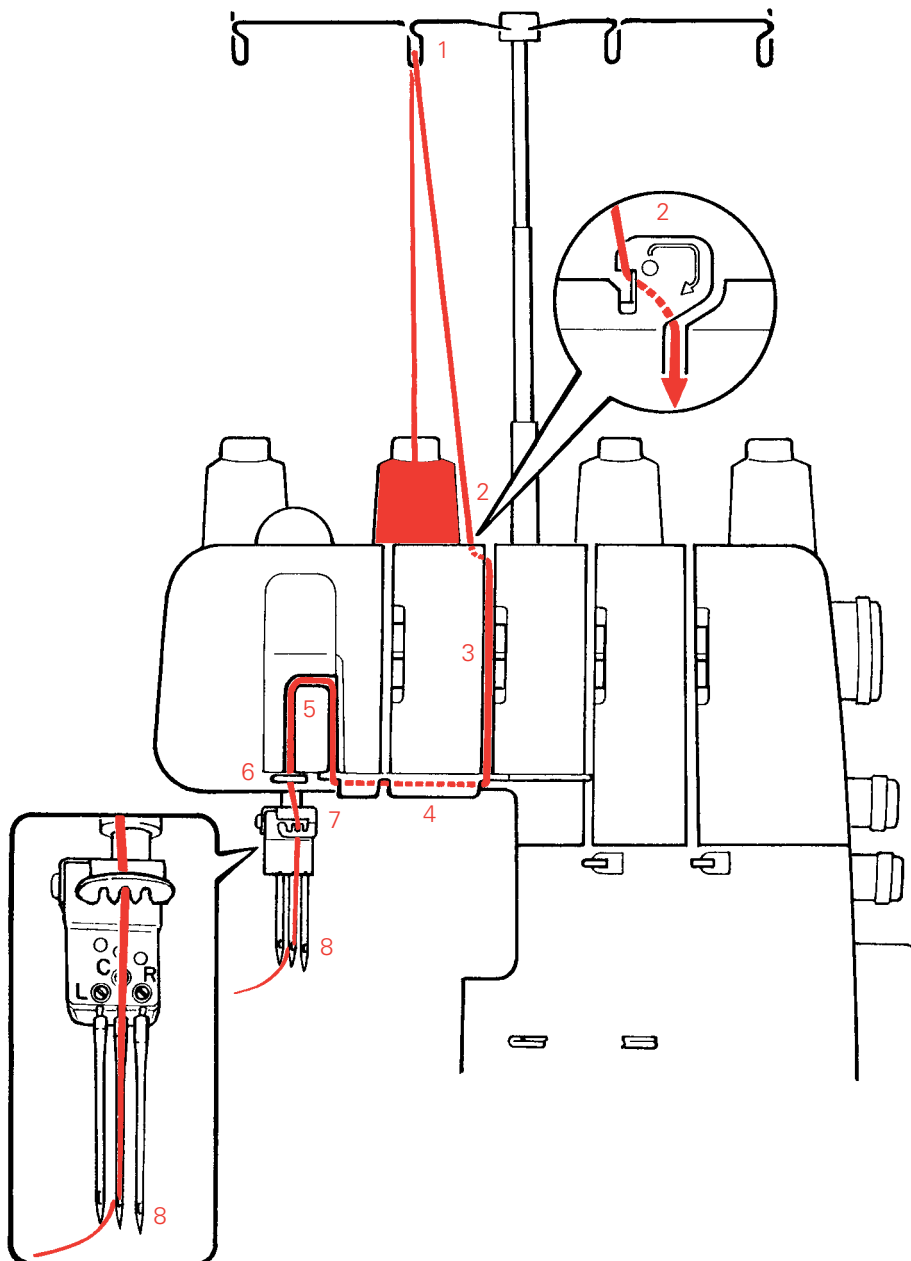

Place the spool on the spool pin as illustrated.

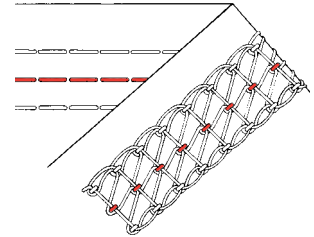

1. Bring the thread up from the spool and lay it from the back to the front into the guide.
2. Thread the first guide.
3. Take the thread through the groove.
- 4., 5., 6. Take the thread under the thread guide plate, through the take up and into the guide.
7. Thread guide on the needle clamp.
8. Thread the needle C from front to back and lay the thread to the left under the foot.

Cover stitch needle L (yellow markings)

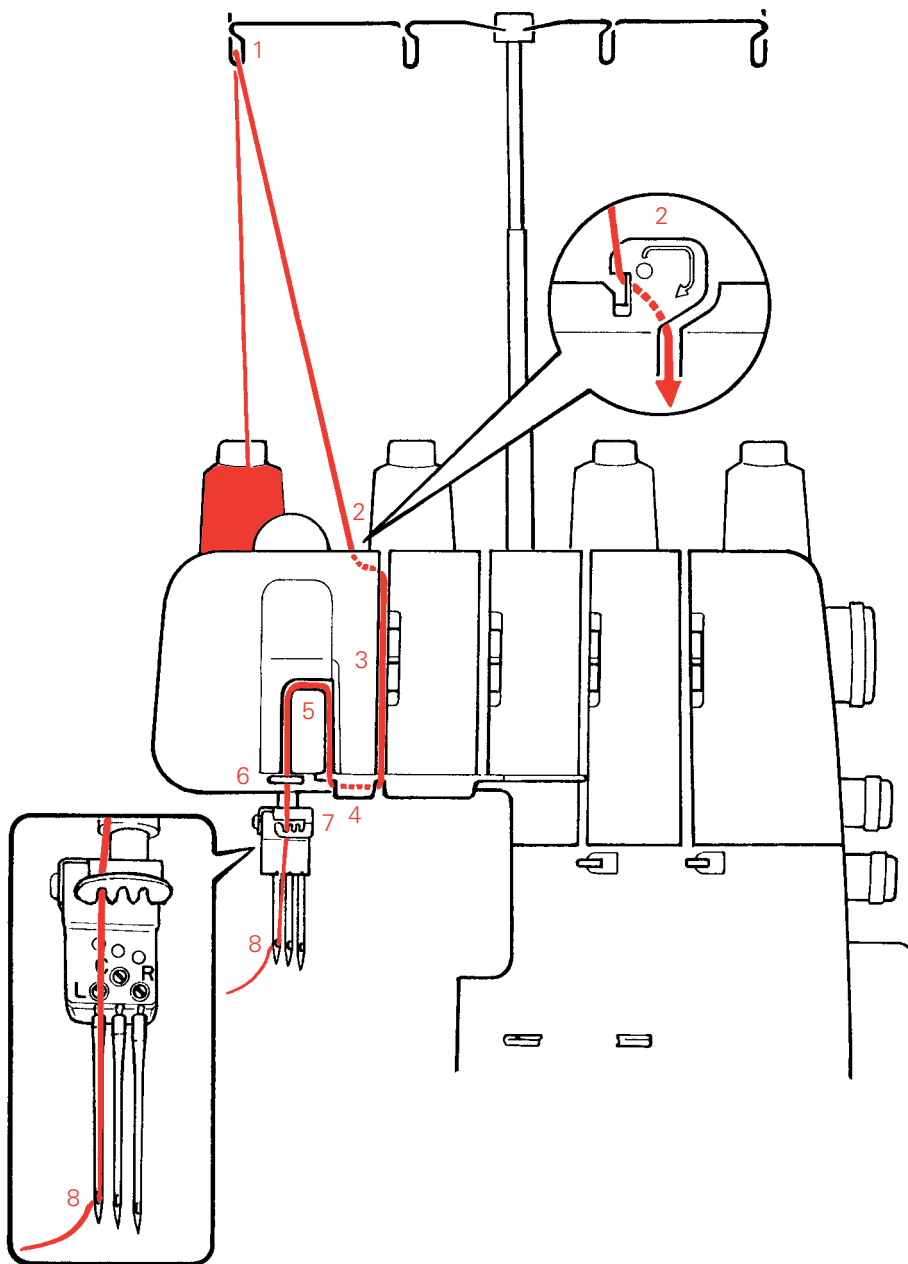

Place the spool on the spool pin as illustrated.

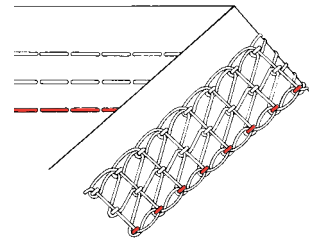

1. Bring the thread up from the spool and lay it from the back to the front into the guide.
2. Thread the first guide.
3. Take the thread through the groove.
- 4., 5., 6. Take the thread under the thread guide plate, through the take up and into the guide.
7. Thread guide on the needle clamp.
8. Thread the needle L from front to back and lay the thread to the left under the foot.

45

After threading

Lower the presser foot and close the looper cover. Switch the power switch to on «1». Test sew: Place a piece of fabric under the presser foot and needles, begin sewing.

When sewing is complete, raise the needles by turning the handwheel away from you (clockwise). This releases the needle threads from the lower looper. Do not use the needle stop button! Raise the presser foot and remove work towards the left. Cut threads (thread cutter).

Re-threading or changing thread

See page 34.

Threading 3-thread cover stitch

46

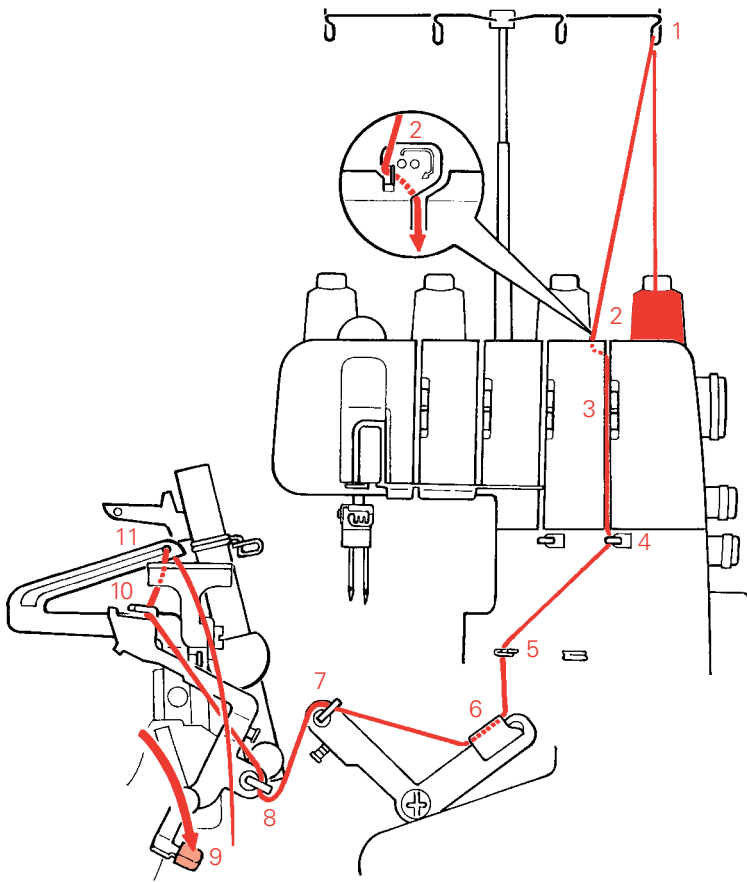

Cover stitch looper
(purple markings)

Place the spool on the spool pin as illustrated. As described on page 42.

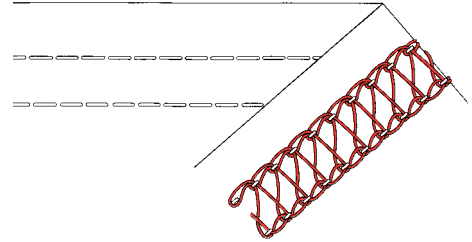

Cover stitch needle R
(brown markings)

Cover stitch needle L
(yellow markings)

Place the spool on the spool pin as illustrated. As described on page 43 and 45.

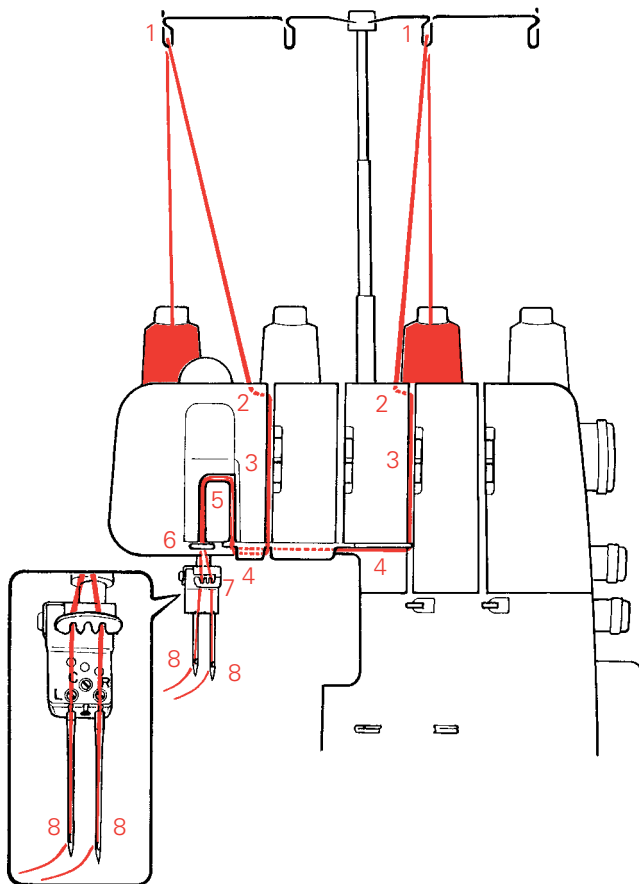
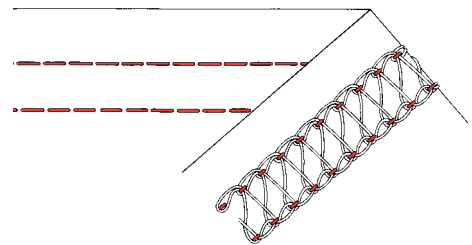

After threading

Test sew: Place a piece of fabric under the presser foot and needles, begin sewing.

When sewing is complete, raise the needles by turning the handwheel away from you (clockwise). This releases the needle threads from the lower looper. Do not use the needle stop button! Raise the presser foot and remove work towards the left. Cut threads (thread cutter).

Threading 3-thread narrow cover stitch

Cover stitch looper
(purple markings)

Place the spool on the spool pin as illustrated.

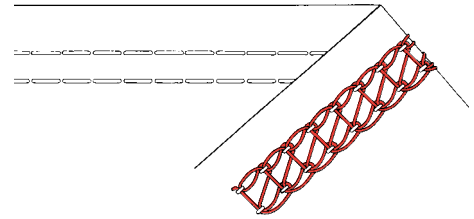
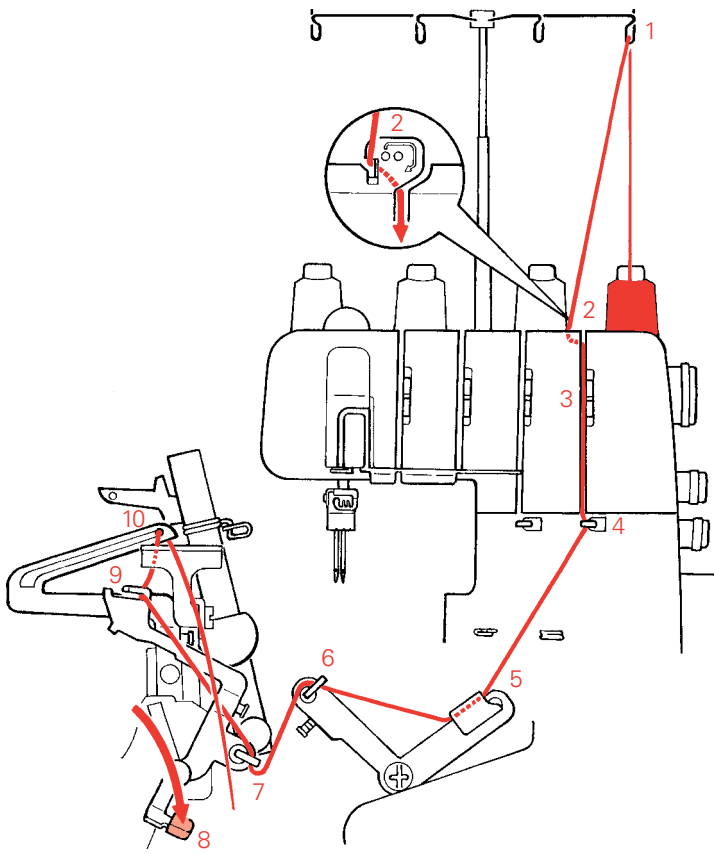

1. Bring the thread up from the spool and lay it from the back to the front into the guide.
2. Thread the first guide on the machine.
3. Take the thread through the groove.
- 4, 5, 6, 7, thread guides as illustrated (purple markings).
8. Press the lever of the auto-threader down.
9. Thread the slit of the threader. Push the auto-threader lever up and it will return to its normal position.
10. Thread the looper eye. Leave the thread end (8 cm or 3") hanging in the machine.

47

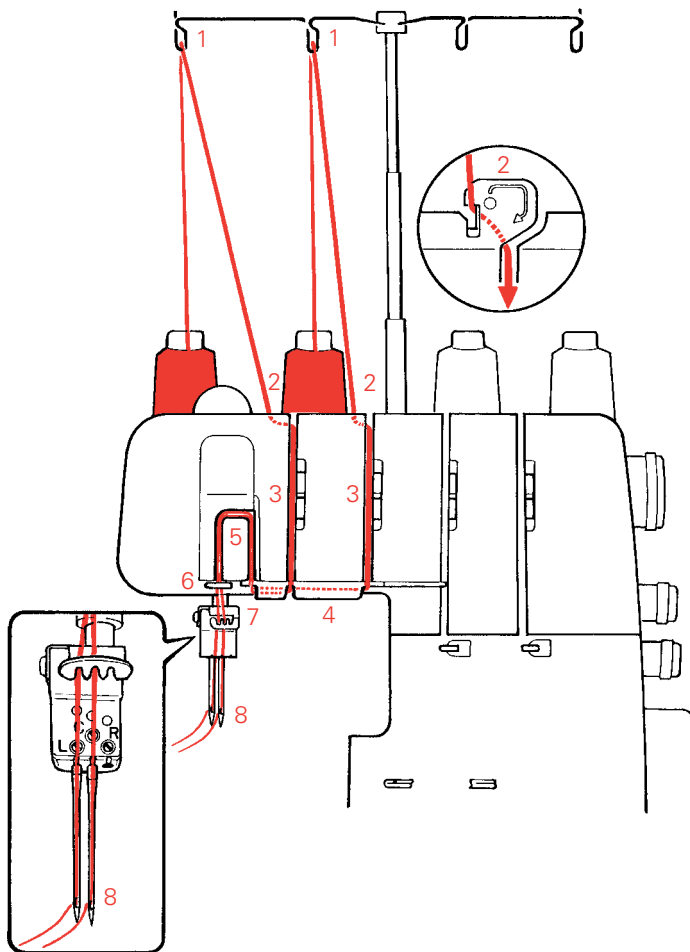

Cover stitch needle C
(green)

Cover stitch needle L
or R (yellow/brown)

Place the spool on the spool pin as illustrated. As described on pages 43, 44 and 45.

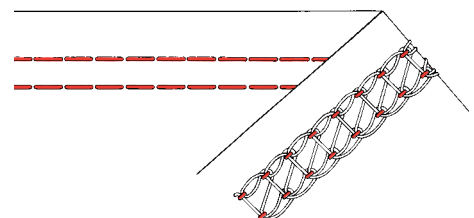

Threading 5-thread top & bottom cover stitch

Top & bottom cover stitch thread (grey markings)

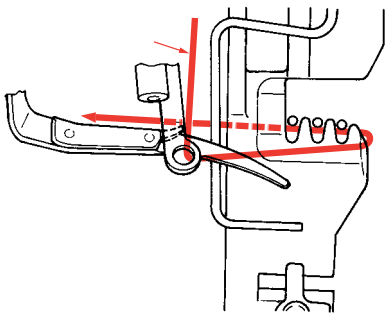
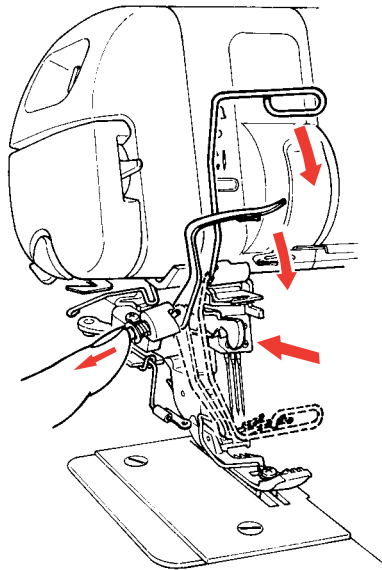
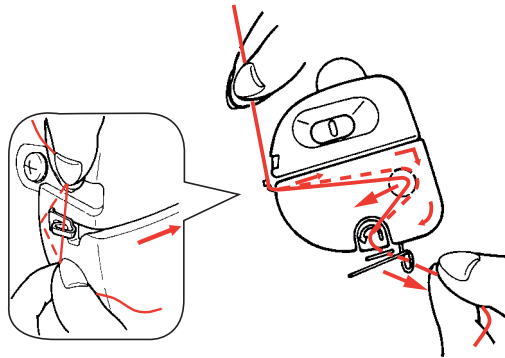
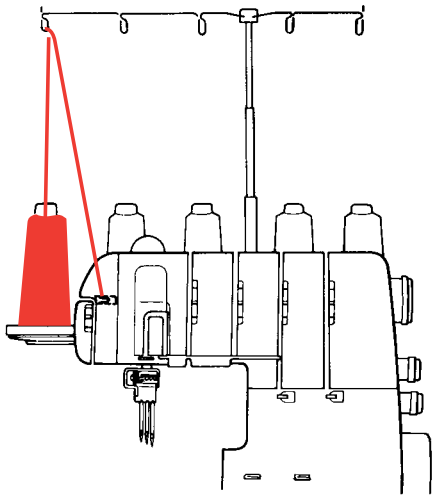

Place the spool on the spool pin as illustrated.

Test sewing with 4 thread (3-needles) cover stitch has been completed. The presser foot is raised, the needle threads are released, the material has been pulled away to the left and threads cut.

You are now ready to thread for the 5 thread top & bottom cover stitch. the machine is still switched on «I».

1. Turn the stitch selection dial to «H».
2. Place a double layer of fabric under the needles and presser foot.
3. Lower the presser foot.
4. Press the needle stop button so that the needles are in their highest position.
5. Press wiper activating lever until it clicks into position.
6. Lower the wiper.
7. Press needle stop button to lower the needles.
8. Switch the power switch to off «O».
9. Bring the thread up from the spool and lay it from the back to the front into the guide.
10. Holding the thread in both hands, thread the first guide located behind the machine head.
11. Take the thread through the groove indicated by arrows on the cover (see diagram).
12. Bring the thread into the guide and eyelet, make sure that the thread is in the tension discs by pulling it firmly with both hands (see diagram).
13. Thread the eyelet of the feeding link (see diagram).
14. Raise the presser foot. Pull the thread over the wiper and in front of the needles and then place it under the presser foot (see diagram).
15. Lower the presser foot and the finger guard.
16. Turn the handwheel towards you one or two revolutions, this will thread the wiper, turn the power switch to on «I», begin sewing.

CAUTION:

Check to be sure the finger guard is in its lowest fixed position.

Top & bottom cover stitch thread (grey markings)

Test sewing with 3 thread (2-needles, 5mm) cover stitch has been completed. The presser foot is raised, the needle threads are released, the material has been pulled away to the left and threads cut.

You are now ready to thread for the 4 thread top & bottom cover stitch. The machine is still switched on «I».

See threading for 5 thread top & bottom cover stitch on page 48.

CAUTION:

Check to be sure the finger guard is in its lowest fixed position.

Threading 4 thread top & bottom narrow cover stitch (2.5mm wide L and C needles only)

Top & bottom cover stitch thread (grey markings)

Test sewing with 3 thread (2-needles, 2.5mm) cover stitch has been completed. The presser foot is raised, the needle threads are released, the material has been pulled away to the left and threads cut.

You are now ready to thread for the 4 thread top & bottom narrow cover stitch. The machine is still switched on «I».

See threading for 5 thread top & bottom cover stitch on page 48.

CAUTION:

Check to be sure the finger guard is in its lowest fixed position.

Cover stitch sewing test and fine tuning

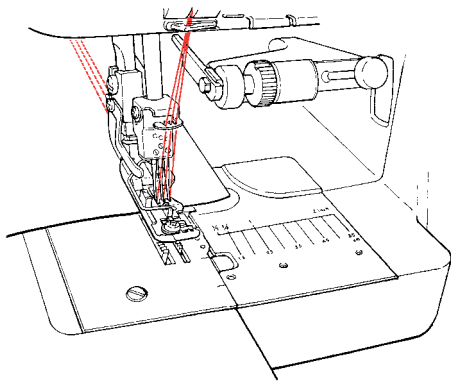
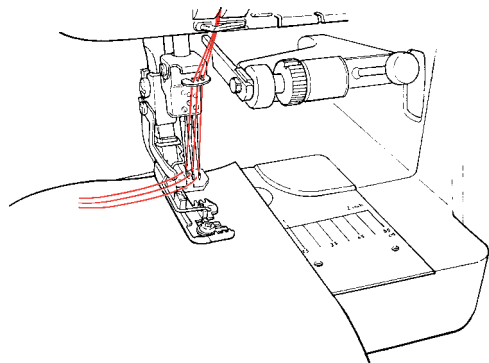

After threading, check that the stitch selection dial is on your desired position for F. Test sew.

Starting to sew:

Raise the presser foot and place a double layer of fabric under the presser foot and needles. Lower the presser foot. To make the first stitch, turn the handwheel towards you to check the position of the needles. Sew. When sewing is interrupted, the needles stop in the fabric.

When sewing is complete, raise the needles by turning the handwheel away from you (clockwise). This releases the needle threads from the lower looper. Do not use the needle stop button! Raise the presser foot and remove work towards the left. Cut threads (thread cutter).

Fine tuning top & bottom cover stitch

Compare your result with the stitch formation on the threading diagram in the looper cover.

The needle threads form two or three straight lines on the upperside of the fabric. They appear as dots on the underside of the fabric.

The wiper thread forms horizontal loops between the two or three needle threads on the upper side of the fabric.

The looper thread forms horizontal and vertical loops between the two or three rows of needle threads on the underside of the fabric to give a stretchy, durable seam.

Incorrect stitch formation can be corrected by fine tuning.

To increase the tension push the fine tuning lever up.
To reduce the tension push the fine tuning lever down.

- A Fine tuning for the needle **L** thread (yellow)
- B Fine tuning for the needle **C** thread (green)
- C Fine tuning for the needle **R** thread (brown)
- D Fine tuning for the lower looper (purple)
- E Fine tuning for the wiper thread (grey)

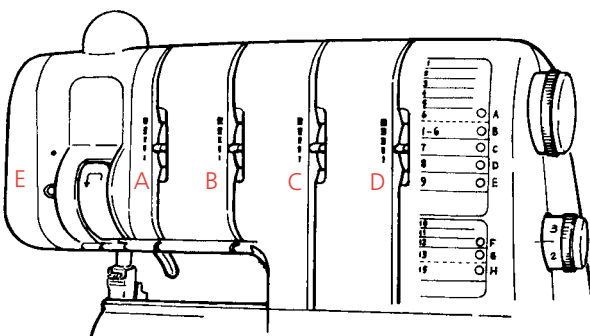
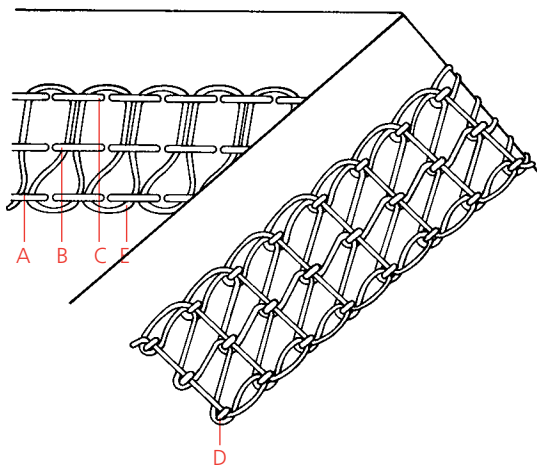

Fine tuning

If the needle threads form loops on the underside of the fabric:

Increase the needle thread tensions.

Tip:

When using decorative threads, attach the deco guide (see page 36) over the looper threading path.

Do not thread the first machine guide but take the thread directly through the deco guide.

Note:

If using needle system JLx2, reduce the needle thread tensions slightly.

Top & bottom cover stitch test sewing and fine tuning

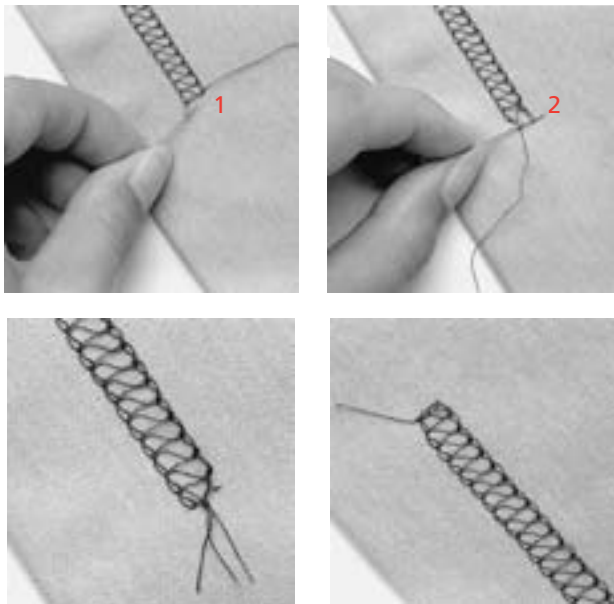

Securing the seam end

After removing your work turn it over to the wrong side. Secure the seam by pulling the loop (1) towards the left. If the looper thread is subsequently pulled to the upper side, the needle thread loops (2) are visible in the stitch formation and can also be pulled through to the wrong side and knotted.

Note:

The cover stitch formation can only come undone at the seam end. It is not necessary to secure the seam begin, because the first stitch is automatically knotted by the subsequent stitches.

52

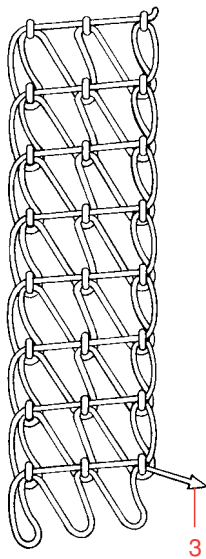

Unpicking seams

The cover stitch formation (chain formation) can be unpicked from the seam end by pulling the looper thread (3). The needle threads and subsequently the wiper thread can then be removed from the right side.

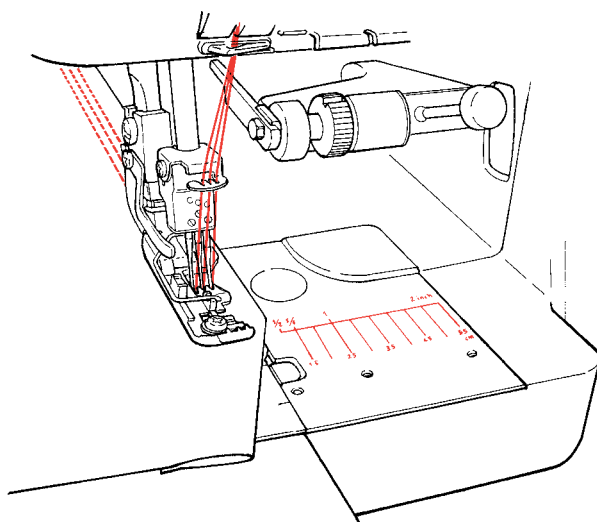

Stitch plate with seam guide lines

The seam guide lines on the extension plate are an invaluable aid for sewing hems, bindings and for top stitching.

Chain stitch looper (purple markings)

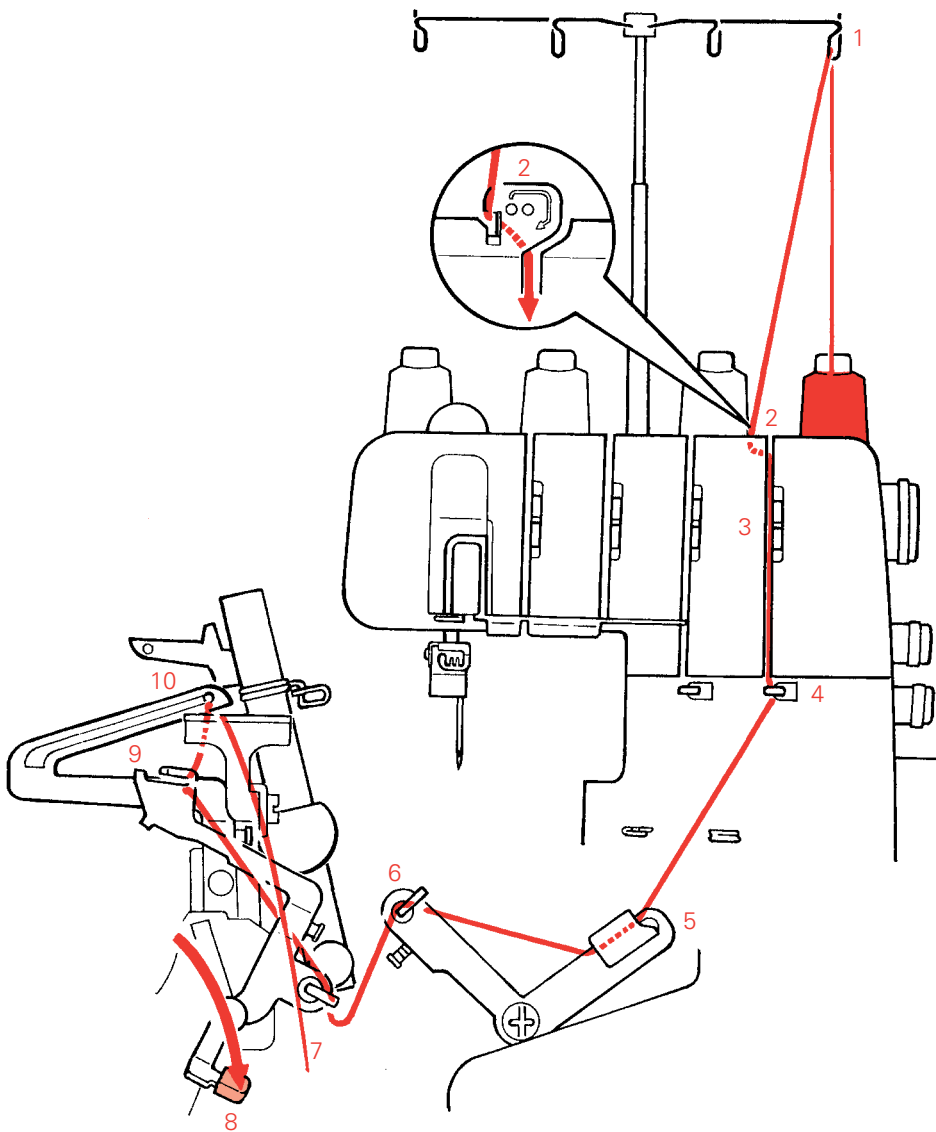

Place the spool on the spool pin as illustrated.

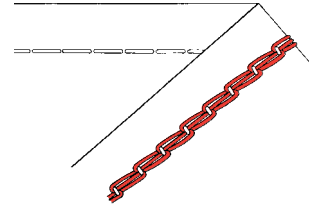

1. Bring the thread up from the spool and lay it from the back to the front into the guide.
2. Thread the first guide.
3. Take the thread through the groove.
- 4., 5., 6., 7. Thread the guides.
8. Press the auto threader down.
9. Thread the slit of the threader. Push the auto threader lever up and it will return to its normal position.
10. Thread the looper eye. Leave thread end (8 cm or 3") hanging in the machine.

Chain stitch threading

Chain stitch needle R (brown markings)

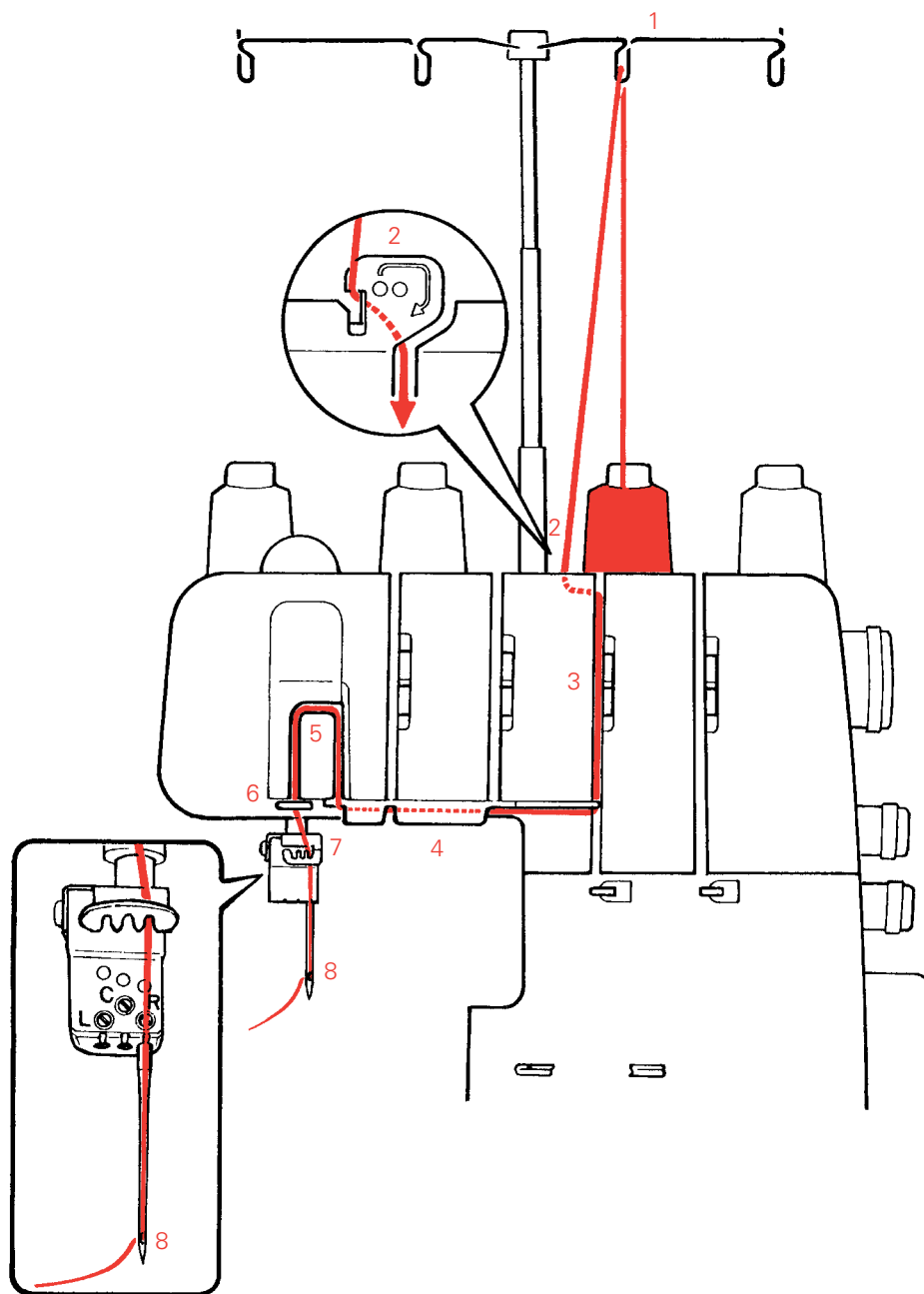

Place the spool on the spool pin as illustrated.

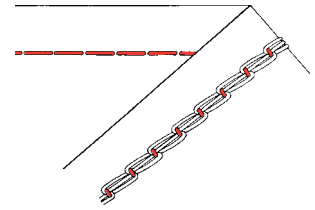

1. Bring the thread up from the spool and lay it from the back to the front into the guide.
2. Thread the first guide.
3. Take the thread through the groove.
- 4., 5., 6. Take the thread under the thread guide plate, through the take up and into the guide.
7. Thread guide on the needle clamp.
8. Thread the needle R from front to back and lay the thread to the left under the foot.

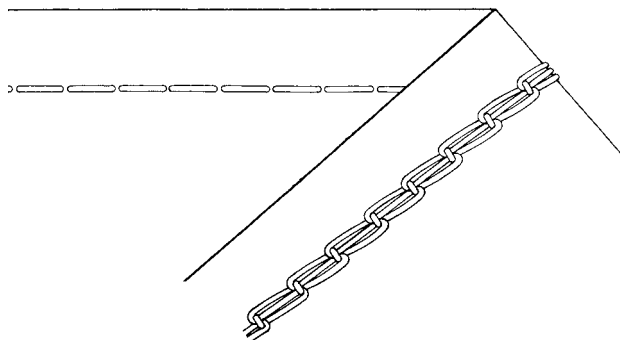

Sewing test

After threading check that the stitch selection dial is on position G. Test sew.

Starting to sew:

Raise the presser foot and place a double layer of fabric under the presser foot and needle. Lower the presser foot. To make the first stitch, turn the handwheel towards you to check the position of the needle. Sew. When sewing is interrupted, the needle stops in the fabric. Continue sewing at the end of the seam, pull out the material slightly to the left to form a chain.

Remove the work carefully to the left. Cutting the thread chain (thread cutter).



Fine tuning chain stitch

Compare your result with the stitch formation on the threading diagram in the looper cover.

The needle thread forms a straight line on the upper side of the fabric.

It appears as dots on the underside of the fabric.

The looper thread forms a chain on the underside of the fabric to give a durable seam.

Incorrect stitch formation can be corrected by fine tuning.

To increase the tension push the fine tuning lever up.
To reduce the tension push the fine tuning lever down.

- A Fine tuning for the lower looper (purple)
- B Fine tuning for the needle R thread (brown)

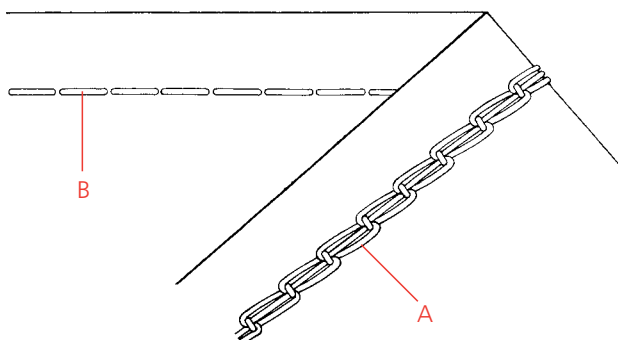

Fine tuning

Tip: When using decorative threads, attach the deco guide over the looper threading path. Do not thread the first machine guide but take the thread directly through the deco guide.

Note:
If using needle system J1x2, reduce the needle thread tensions slightly.

Securing the seam end

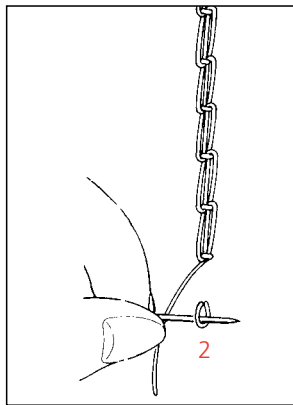
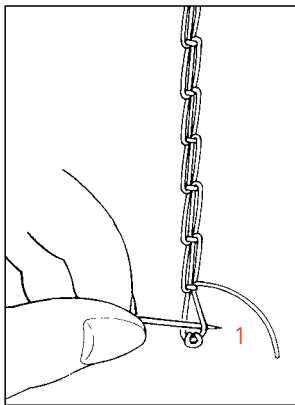

After removing your work turn it over to the wrong side. Secure the seam by pulling the loop (1) towards the left. If the looper thread is subsequently pulled to the upper side, the needle thread loops (2) are visible in the stitch formation and can also be pulled through to the wrong side and knotted.

Note:

It is not necessary to secure the seam begin, because the first stitch is automatically knotted by the subsequent stitches.

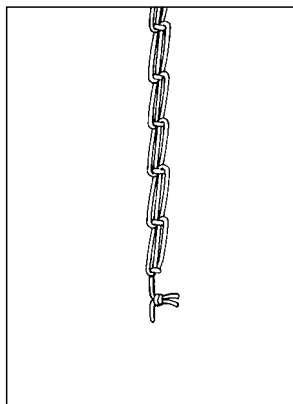
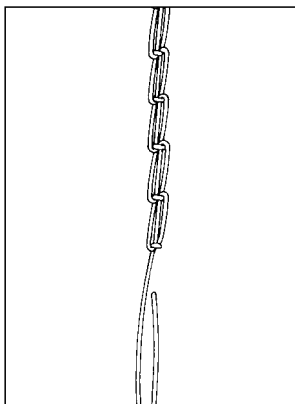

Unpicking seams

The chain stitch formation can be unpicked from the seam end by pulling the looper thread (3). The needle threads can then be removed from the right side.

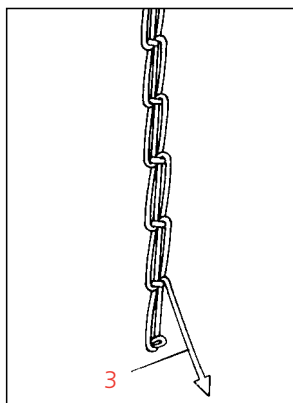

Converting from overlock to cover/chain



The individual steps of the conversion sequence are described in detail in the chapter: «Cover/Chain and top & bottom Stitch Functions» (pages 38–41).

1. Turn stitch selection dial to position **F** for cover stitch or **G** for chain stitch.
2. Press the needle stop button to lower the needle clamp.
3. Remove the waste collector and open the looper cover.
4. Switch conversion arm from overlock to cover/chain stitch.
5. Remove the knife guard and attach the cover/chain stitch extension plate.
6. Turn the handwheel to bring the needle clamp to its highest position.
7. Raise the presser foot and swing it out.
8. Raise the upper knife and the upper knife arm.
9. Cut all threads and remove any chain-off.
10. Insert needles in the appropriate cover/chain stitch positions (tools in looper cover).
11. Thread cover/chain stitch looper (purple markings) leaving 8 cm or 3" of thread hanging in the machine. Close the looper cover.
12. Thread cover or chain stitch needles, place threads under the presser foot.
13. Swing back presser foot. Adjust the stitch length and differential feed to suit the stitch and fabric.
14. Sew to the end of the seam, turn the handwheel away from you (clockwise) to raise the needles, lift presser foot, remove work and cut threads.

Converting from cover stitch position F (4 thread cover stitch) to top & bottom cover stitch (position H)



Test sewing with 4 thread (3-needles) cover stitch has been completed. The presser foot is raised, the needle threads are released, the material has been pulled away to the left and threads cut.

You are now ready to thread for the 5 thread top & bottom cover stitch. The machine is still switched on «I».

1. Turn the stitch selection dial to «H».
2. Place a double layer of fabric under the needles and presser foot.
3. Lower the presser foot.
4. Press the needle stop button so that the needles are in their highest position.
5. Press wiper activating lever until it clicks into position.
6. Lower the wiper.
7. Press needle stop button to lower the needles.
8. Switch the power switch to off «O».
9. Bring the thread up from the spool and lay it from the back to the front into the guide.
10. Holding the thread in both hands, thread the first guide located behind the machine head.
11. Take the thread through the groove indicated by arrows on the cover (see diagram).
12. Bring the thread into the guide and eyelet, make sure that the thread is in the tension discs by pulling it firmly with both hands (see diagram).
13. Thread the eyelet of the feeding link (see diagram).
14. Raise the presser foot. Pull the thread over the wiper and in front of the needles and then place it under the presser foot (see diagram).
15. Lower the presser foot and the finger guard.
16. Turn the handwheel towards you one or two revolutions, this will thread the wiper, turn the power switch to on «I», begin sewing.

CAUTION:

Check to be sure the finger guard is in its lowest fixed position.



Converting from top & bottom cover stitch (position H) to cover/chain stitch position F (4 thread cover stitch)



Sewing with 5 thread (3-needle) top & bottom cover stitch has been completed. The presser foot is raised, the needle threads are released, the material has been pulled away to the left and threads cut.

You are now ready to convert back to cover/chain stitch position F/G and the machine is still switched on «I».

1. Remove wiper thread.
2. Lift finger guard and wiper.
3. The needles are in their highest position.
4. Pull out wiper activating lever until it clicks into position.
5. Turn the stitch selection dial to the desired position (F or G).
6. If position G selected, remove all needle(s) not in use (only needle R is required).
7. If position F is selected, place a double layer of fabric under the presser foot and needles.
8. Lower the presser foot. Turn the handwheel towards you one or two revolutions, begin sewing.



Converting from cover/chain stitch to overlock



The individual steps of the conversion sequence are described in detail in the chapter: «Cover/Chain and top & bottom Stitch Functions» (pages 38–41).

IMPORTANT:

When cover stitch presser foot (compensating foot) is attached, remove it before converting to overlock.

1. Turn the stitch selection dial to desired position, (A-E).
2. Lower the presser foot and press Needle stop to lower the needle clamp.
3. Open looper cover and slide the conversion arm from cover/chain to overlock.
4. Remove the extension plate and replace it with the knife guard.
5. Turn the handwheel to bring needle clamp to highest position.
6. Raise the presser foot and swing it out. Cut all threads and remove any chain-off.
7. Insert overlock needle(s) in the appropriate position for selected stitch (tools in looper cover).
8. Thread overlock looper(s) according to stitch selected.
9. Thread needle(s).
10. Swing presser foot back.
11. Lower the upper knife arm and upper knife if necessary.
12. Close the looper cover and attach the waste collector.
13. Adjust the stitch length, differential feed and cutting width to suit stitch and fabric.
14. Test sew: Place a piece of fabric under the presser foot and needle(s), lower the presser foot. Sew. Continue sewing at the end of the seam until an 8 cm or 3" chain is formed. Cut threads.



Pins



▲ 1

▼ 2

If you pin your work, remove the pins while sewing before they get near the knife, or pin parallel about 2 cm (1") from the fabric edge (see 1, 2).

Tip:

Use pins with coloured heads which are easier to see in thicker, soft fabrics.



Tape guide

The standard presser foot is equipped with a guide for sewing on tape to strengthen or stabilise shoulder, or side seams in garments made from knits or stretch fabrics. The guide is also ideal for sewing on narrow elastic for lingerie, swim and gymwear.

- Raise the needles (Needle stop).
- Raise and swing the presser foot out.
- Place the tape under the foot, slip it into the guide from the right and pull through slightly.
- Swing the presser foot back and lower it.
- Sew a few stitches on the tape.
- If necessary, loosen the fixation screw (1) and adjust the tape guide to suit the width of the tape (2).
- Retighten the screw.
- Raise the tip of the presser foot, place work underneath the tape/elastic and sew.

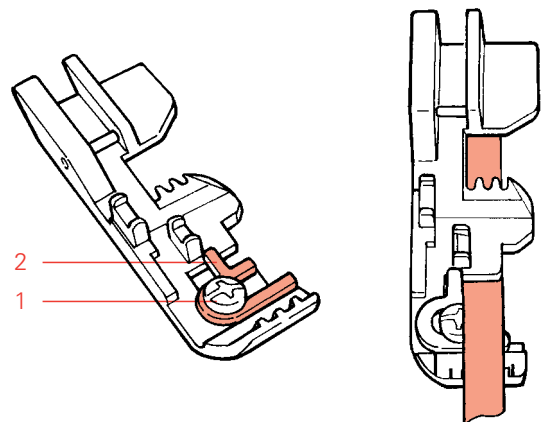
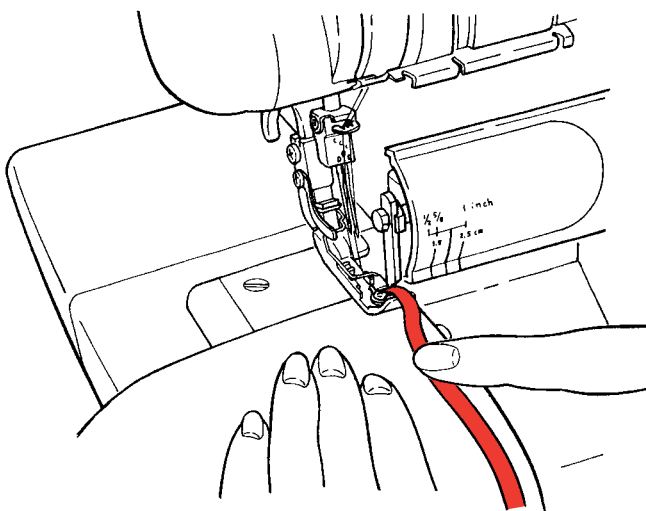

Gathering



Use the differential feed to gather a single layer of fabric before sewing it to a garment. For example, sleeve heads and lower edges, yokes, lace edging or frills.

Settings:

- Stitch: 4 thread overlock, position A/B
- Differential feed: 2
- Stitch length: 3–4
- Cutting width: 2

Note:

Increase the needle tensions for a tighter gather.

Tip:

After sewing, loosen the needle threads from the thread chain with a pin or the BERNINA seam ripper and pull the threads gently to gather fine fabrics.



Presser foot markings

The markings on the presser foot help to guide the fabric.

- A Cutting line (cutting width 2)
- B Needle R insertion point (cover and chain stitch only)
- C Needle C insertion point
- D Needle L insertion point
- E 1 cm distance from cutting line (A) (cutting width 2)

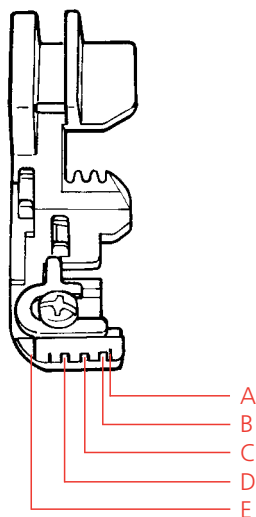

Seam allowance markings

The seam allowance markings on the looper cover allow you to guide the fabric easily and perfectly according to the chosen or given seam allowance. The measurements are taken from the point of needle insertion.

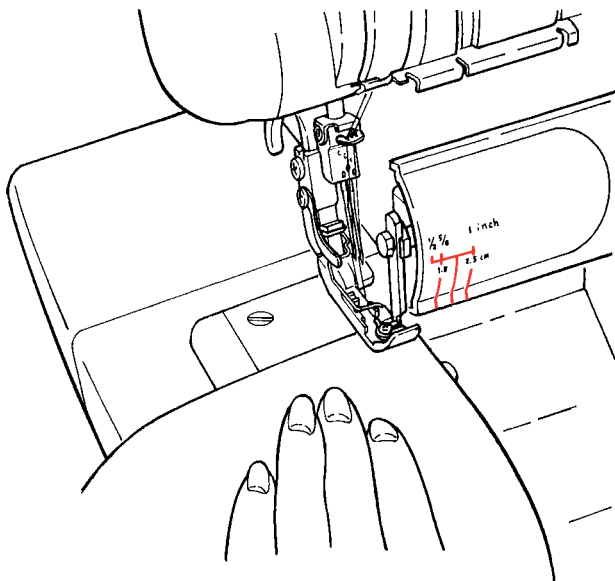

Seam guide right

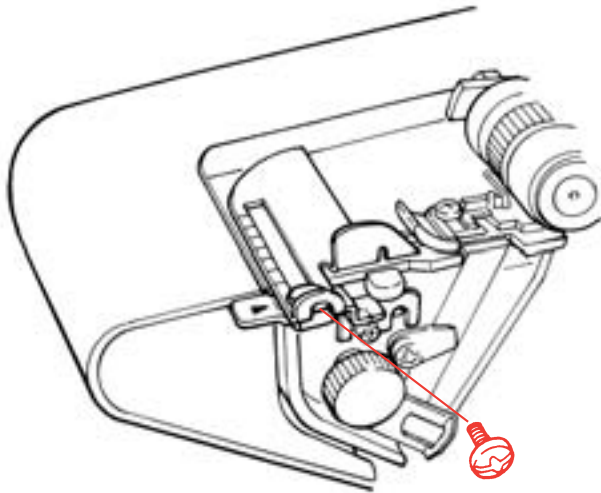

Loosen the screw. Position the attachment (accessory bag) over the screw and retighten the screw.

Pull out the adjustable guide to the right until it is line with the desired marking on the looper cover.
Feed the fabric edge along the guide, an even amount of fabric will be cut off.

To sew without cutting, push the guide to the left to line up with the cutting line on the presser foot.

Note:
Push the guide fully to the left to open the looper cover.

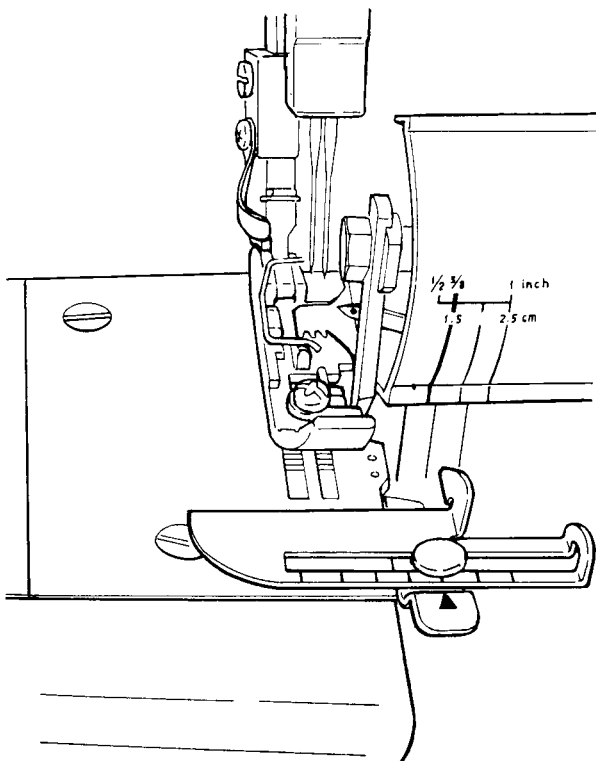

Sewing in the thread chain – seam begin



▲ 1



▲ 2

- Sew to form a 3–4 cm (2") chain.
- Position fabric and sew one stitch.
- Insert needles (Needle stop down).
- Raise the presser foot.
- Pull the thread chain slightly and from the left, place it under the presser foot (in the tape guide if you wanted).
- Lower presser foot.
- Start sewing, sewing over the thread chain.
- After approx. 2 cm/1", guide the thread chain towards the knife to cut off the excess (see 1, 2).

▼ 3

▼ 4



▼ 5

Sewing in the thread chain – seam end

- Sew to the end of the seam.
- Raise the needles (Needle stop down).
- Raise the presser foot.
- Remove work carefully towards the back.
- Turn work over and towards you and lay it under the presser foot so that the needle enters the fabric with the first stitch.
- Lower the presser foot.
- Sew carefully over the previous stitching without cutting for about 2–3 cm (1").
- Raise the tip of the foot and turn work away from you.
- Stitch off the edge (see 3, 4).



▼ 6

Securing thread chains

Leave a 12 cm/5" chain at the beginning and at the end of the seam so that it can be knotted or pulled through the first/last few stitches with a darning needle (see 5).

Sewing curves

Overlocking outside and inside curves is easy. As the fabric is first cut and then sewn, it is important to watch the knives and not the needles. Guide the fabric as straight as possible towards the knife. Avoid letting the fabric slip between the knives and needles (see 6).



Sewing outside corners



▲ 1



▲ 2



▲ 3



▲ 4



▲ 5

▼ 6



- Snip into each corner along the stitching line.
- Sew up to the corner and slightly over the edge of the fabric.
- Raise the needle (Needle stop).
- Raise the presser foot.
- Pull the work out at the back slightly to clear the threads from the stitch finger.
- Turn the fabric and lay it under the presser foot so that the cut edge of the fabric is against the knife.
- Lower the presser foot.
- Lower the needles (Needle stop down).
- If necessary, pull all the threads taut above the first machine guide.
- Continue sewing (see 1, 2, 3).

Sewing inside corners

- Snip into the corner up to the stitching line.
- Sew until the knife reaches the cut.
- Fold fabric towards you.
- Sew over the corner.
- Fold fabric away from you.
- Continue sewing (see 4, 5, 6).

Sewing circular or tubular items



▲ 1



▲ 2



▲ 3



▲ 4



▲ 5

▼ 6



- Cut away a small section of the seam allowance.
- Raise the needles (Needle stop).
- Raise the presser foot.
- Position the fabric under the presser foot so that the edge of the cut is against the knife.
- Lower the presser foot.
- Sew.
- When the seam is complete, sew a few stitches over the previous stitches without cutting.
- Raise the tip of the presser foot and turn work away from you.
- Sew off the edge (see 1, 2, 3).

Unpicking seams

Method 1:

Cut the loops formed by the looper threads with sharp scissors or the BERNINA seam ripper. Pull slightly on the threads and the seam will come undone (see 4, 5).

Method 2:

Loosen the loops formed by the needle threads with a pin or your BERNINA seam ripper. Pull first on the needle and then on the looper threads and the seam will come undone (see 6).

Simple hem



Stitch length: 3–4
Differential: N–2 (depending on fabric)

- Mark hem depth and fold or press.
- Place fabric under the foot and guide the folded edge along a line on the stitch plate.

The hem is sewn and the raw edge on the wrong side is neatened simultaneously. Surplus seam allowance can be trimmed closed to the stitches if desired.

Ideal for all stretch fabrics.

Note:
This applies to top & bottom cover stitch as well.

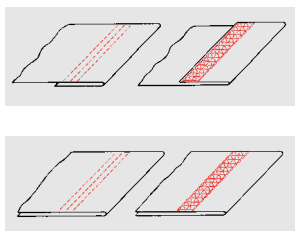

Flat joining seam



Stitch length: 3–4
Differential: N–2 (depending on fabric)

- Mark seam allowances.
- Turn or press under the edge of the upper fabric (if not already neatened).
- Place edges on top of one another.
- Guide fabric edge along one of the side sections of the foot.

When sewing on elastic or lace, place it on the fabric and cover with the seam allowance. The underside (raw edge) will be neatened. If the seam allowance is more than 6 mm (1/4”), it can be trimmed close to the stitches after sewing.

Ideal for all hems and edges with elastic in jerseys, knits and stretch fabrics. Suitable for shaped pieces such as raglan sleeves, curved inserts and bindings.

Note:
This applies to top & bottom cover stitch as well.

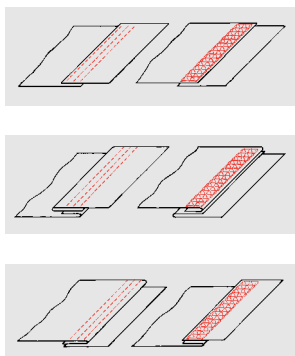

Edges with elastic



Stitch length: 3–4
Differential: 0.7–N

- Sew on elastic with 4-thread overlock
- Turn the raw edge to the width of the elastic and topstitch from the right side.

Guide the fold along the right section of the foot or use one of the lines on the stitch plate as a guide. The hem is stretchy, durable and regains its shape after stretching.

Ideal for swimwear, gymwear, children's clothing, skirt and trousers waistbands.

Note:

This applies to top & bottom cover stitch as well.

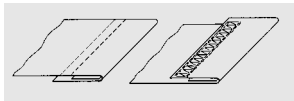
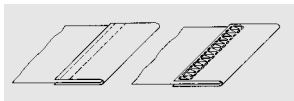
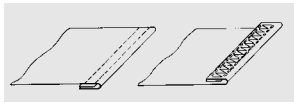

Binding



Stitch length: 3–4
Differential: N

Cut bias binding or bias cut strips to the desired width, mark if wanted and press or pin. Lay the binding round the fabric edge and sew. Guide the edge of the binding on the right of the fabric along the left side section of the foot. The edge of the binding on the wrong side (raw edge) is neaten by the looper thread. Trim surplus binding close to stitches.

Ideal for neck edges on stretch fabrics, armholes and finishes on tubular items.

Note:

This applies to top & bottom cover stitch as well.

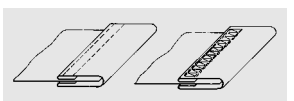
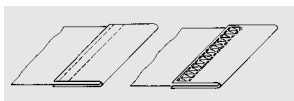
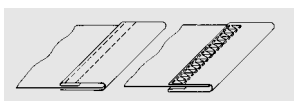

Top stitching seams / ribbing / yokes



Stitch length: 3–4
Differential: 0.7–N

- Fold or press seam to one side.
- Edge stitch (or at distance desired) from the right.
- Guide the edge of the fabric along the side sections of the foot.

Cover stitch is perfect for top and edge stitching overlock seams in all stretch fabrics to give a professional, durable and decorative finish.

Ideal for sweatshirts, all garments made from jersey such as dresses, jackets, coats and garments made with the patchwork technique.

Note:
This applies to top & bottom cover stitch as well.

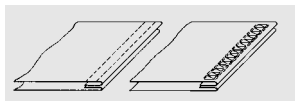
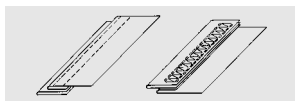
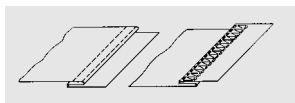

Decorative stitching



Stitch length: 3–4
Differential: 0.7–N

The additional space to the right of the needle allows you to sew decorative effects on the fabric.

The «wrong» side of the stitch can be used on the «right» side of the fabric. It is particularly effective if fine decorative threads are used in the looper. Use the Deco Guide if necessary (page 36).

- Draw pattern lines on the right or left side of the fabric.
- Sew.

Tip:
Use a double layer of fabric or stabiliser. Remove or trim after sewing.

Note:
This applies to top & bottom cover stitch as well.

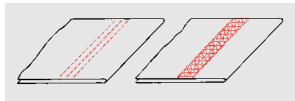
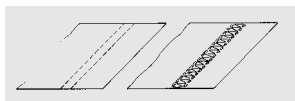

Practical Sewing - chain stitch

Gathering with chain stitch

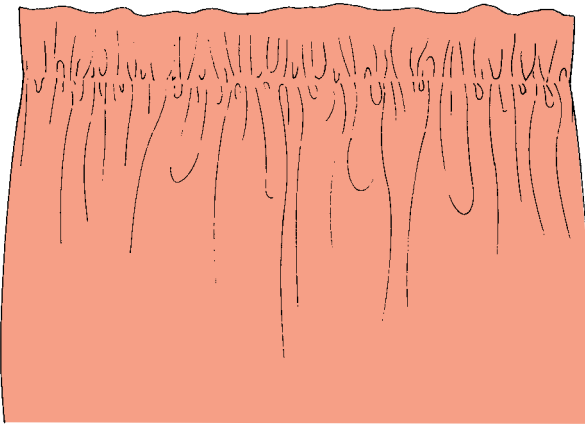

Single layers of fabric can be gathered with chain stitch and differential feed.

Differential feed: 2

Stitch length: 4

Tensions: pre-set

Binding



Stitch length: 3–4

Differential feed: N

Cut the binding four times the width of the finished width.

Mark if necessary and press.

Place the binding right side to the wrong side of the fabric, pin if wanted and sew.

Turn the binding to the right side and stitch from the right.

Note:

For fine fabrics use the cover stitch foot (compensating foot).

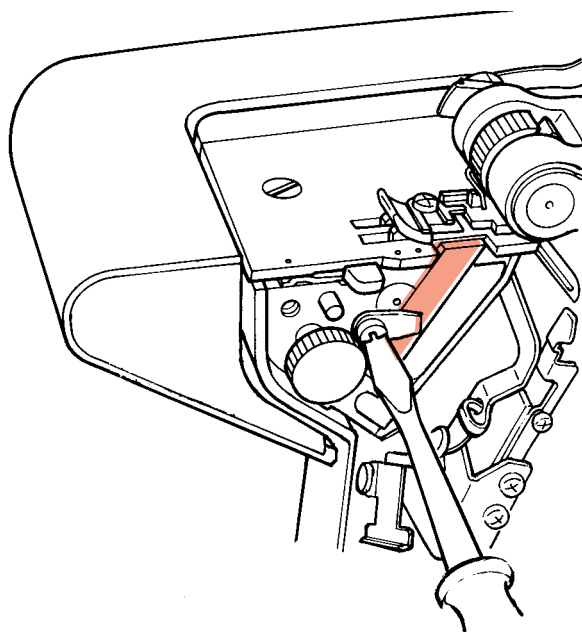
WARNING! Please refer to the safety instructions.

Always disconnect the machine from the electricity supply when carrying out any of the following tasks.

Upper knife

The upper knife (moving knife) is made from special material and generally does not need replacing. Should it get damaged, it can be replaced by your local BERNINA dealer.

Replacing the lower knife

- Open the looper cover.
- Raise fully the needles.
- Raise the upper knife.
- Loosen the setscrew on the lower knife retaining plate with the large screwdriver.
- Remove the lower knife.
- Fit the replacement knife (accessory bag) in the groove so that the sharp edge is in line with the stitch plate.
- Retighten the setscrew.
- Lower the upper knife.
- Close the looper cover.
- Test sew.

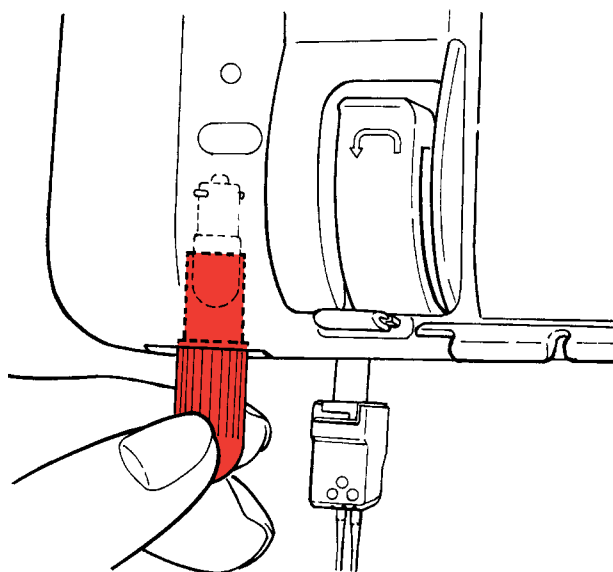
**Replacing the bulb**

Using the special bulb holder provided in the accessory bag, press upwards against the bulb, turn to the left and remove the bulb.

Place the new bulb on the holder. Insert into the bulb fixation, press upwards and turn to the right until the bulb engages.

Replacement bulbs for your BERNINA overlocker are available at your BERNINA dealer. Use max. 12 Volt/5 Watt bulbs.

Cleaning and lubricating

Dust and fluff collect on and in the machine. This should be removed regularly.

Your BERNINA overlocker requires very little lubrication as the main components are made of special materials. Now and then lubricate the points illustrated.

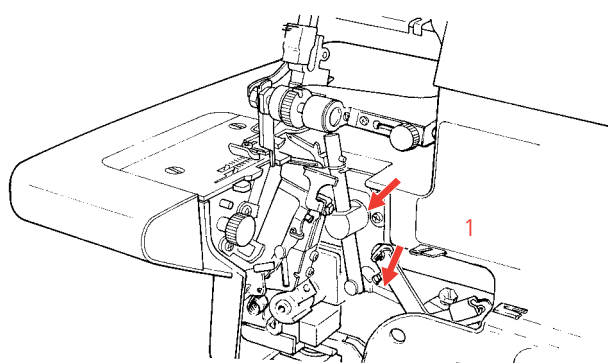

Trouble shooting guide

Problem:	Cause:	Solution:
The machine does not sew.	The presser foot is up or the looper cover is open, the safety control lamp is on.	Lower the presser foot. Close the looper cover.
	The main switch is not on.	Switch machine on. Main switch to I.
	The machine is not plugged in.	Plug machine into main socket.
Fabric does not feed evenly:	Differential feed is wrongly adjusted.	Check the differential feed setting.
	Presser foot pressure is too low.	Adjust the presser foot pressure.
	Lower or upper knife is blunt or wrongly positioned.	Replace the lower or upper knife.
Thread breaks:	Thread tension is too tight for the thread being used.	Reduce thread tension.
	Needles not inserted correctly.	Insert needles fully into needle clamp with flat side to the back.
	Wrong needles.	Use system 130/705 H needles for overlock or cover stitch, or JLx2 for cover stitch.
Needles break:	Needles are bent, blunt or points are damaged.	Replace the needles.
	Needles are not inserted correctly.	Insert needles fully into needle clamp with flat side to the back.
	Fabric was pulled while sewing.	Guide fabric slightly with both hands.
Skipped stitches:	Needles are bent or blunt.	Replace the needles.
	Wrong needles used.	Use system 130/705 H needles for overlock and cover-/chain stitch or JLx2 for cover stitch.
	Presser foot pressure is too low.	Increase foot pressure.
Poor stitch formation:	Sewing position incorrect.	Turn the stitch selection dial to the correct position.
	Threads are not between the tension discs.	Check if thread is lying between the tension discs.
	Thread has got caught.	Raise the presser foot, pull the threads and lower the presser foot.
	Machine is incorrectly threaded.	Check threading path of each thread.
Seams flute or wave, particularly when sewing knits.	Presser foot pressure is too high.	Reduce presser foot pressure.
	Differential feed is set incorrectly.	Adjust differential feed between N and 2.
	Fabric was pulled while sewing.	Guide fabric slightly.

Problem:	Cause:	Solution:
Seams pucker:	Differential feed is set incorrectly.	Adjust differential feed to 0.7 - N.
	Needle thread tensions are too tight.	Reduce needle thread tensions.
	Looper thread tension is too tight for thread.	Use the Deco Guide.
Fabric edges curl:	Too much fabric in the stitch.	Reduce the cutting width.
	Stitch selection lever is on roll hem.	Set selection lever to overlock.
Thread loops are too loose.	Too little fabric in the stitch.	Increase the cutting width.
Machine stops sewing:	Should the machine stops sewing, the motor cuts out for 2 seconds, afterwards you can continue sewing.	Check why the machine stopped. The machine will sew again after the safety cut out.
Fabric cannot be removed: (cover stitch and top & bottom cover stitch)	Handwheel was turned anti-clockwise.	Insert needles into fabric, press Needle stop, turn the handwheel away from you (clockwise) to raise needles. Remove work.

Index

A		F		N		R	
Accessories	9, 10	Fabric edges curl up	73	Neatening		Replacing	
· looper cover	9	Fabric edges wave	72	· edges	26, 27	· bulb	71
· in accessory bag	10	Fabric feed	72	· seam allowances	26, 27	· knives	71
B		Fabric/needle/thread	23	· thick fabrics	24, 26, 27	· knife guard	41
Binding (cover stitch/top		Feed – uneven	72	· cover stitch	28, 29	· needles	21
& bottom cover stitch)	68	Fine tuning		· overlock	26, 27	· presser foot	16
Bulb	71	· chain stitch	55	Needles		· spools/cones	34
· holder	71	· cover stitch	51	· breaking	23, 72	R needle	
· replacing	71	· overlock stitches	35	· inserting/replacing	21	· threading	43
C		Finger guard	6, 7	· positions		· tension	25, 35, 51
Chain stitch	28, 53, 54	First thread guide	30	(overlock/cover/ chain stitch)	21	Roll hem	22, 26, 27
· practical sewing	70	Flat seams	27, 29	· size	23	S	
· test sew	55, 56	· cover stitch	67	· system	23	Safety control light	14
· threading	53, 54	· overlock	27	· thread/fabric	23	Safety features	14, 40
Cleaning and lubricating	71	Foot control		Needle thread tension	25	· cover stitch	40
Cloth plate	15	· attaching	11	· fine tuning chain stitch	55	· overlock	14
Cones, positioning	12	Free arm	15	· fine tuning cover stitch	51	Safety regulations	3
Conversion arm		G		· fine tuning overlock	35	Seams	
(overlock/cover stitch)	39	Gathering	62	· fine tuning top & bottom	51	· adjusting width	18
Corners, sewing	65	H		New spools/cones	34	· allowances/ neatening	26, 27
Correct stitch formation		Handwheel	15	· knotting on	34	· in fine fabrics	27
· cover stitch/top &		Hems with cover stitch/ top & bottom cover stitch	67	O		· in knits	27
· overlock stitches	35	K		One looper stitches		· in stretch fabrics	27
Cover/chain stitch	38	Knives		· 2 thread overlock	26, 27	· puckering	18, 19
· extension plate	6, 10	· position lower knife	17	· 2 thread flatlock	26, 27	· unpicking	66
· converting to overlock	60	· raising upper knife	20	· 2 thread roll hem	26, 27	· waving knits	18, 19
· converting from overlock	57	· raising upper knife arm	40	· 3 thread super stretch	26, 27	Seam guides	
· needle positions	21	· replacing	71	· upper looper converter	22	· right	63
· presser foot	10, 16	Knife guard	41	Opening/closing		Seam guide markings	62
Cover stitch applications		L		· looper cover	15	Securing thread ends	
· 3 thread cover stitch	28, 29	L needle	21	Overlock stitches		· chain stitch	56
· 4 thread cover stitch	28, 29	· threading	33, 34, 44, 45	· 4 thread	26, 27	· cover stitch	52, 58
· binding	68, 70	· tension	25, 35	· 3 thread	26, 27	Selection	
· flat joining seams	67	Legend		· 2 thread	26, 27	· cover/chain stitch/ overlock	24, 25
· edges with elastic	68	· stitch selection	24, 25	· flatlock	26, 27	· overlock/roll hem	22
· simple hems	67	Light switch	14	· roll hem	26, 27	· stitch chart	26, 29
Cutting width	17, 18	Looper cover		· super stretch	26, 27	Sewing in tape	61
D		· opening/closing	15	P		Sewing light	14
Deco Guide	36	· lower looper threading (overlock)	32	Practical sewing		Sewing speed	11
Decorative edge finishes	26, 27	· lower looper threading (cover stitch)	42	· cover stitch/ top & bottom	67–69	Sewing test	
Decorative overlock threads	23	· lower looper threading (chain stitch)	53	· overlock	61–66	· chain stitch	55
Decorative stitching with cover stitch	69	· upper looper threading	31	· chain stitch	70	· cover stitch	51
Details of machine	6, 7, 8	· upper looper release (converter)	22	Poor stitch formation	72	· overlock	35
Differential feed	18, 19	Loose loop formation	35, 72	Power switch	14	Sewing	
Domestic spools	12	M		Presser foot		· tubular items	66
E		Machine does not sew	72	· changing	16	· with decorative threads	23
Edges		Maintenance	71	· cover stitch foot	10	· with differential feed	18, 19
· finishing	26, 27	Micro safety switch	14	· raising	15	Skipped stitches	72
· hemming				· markings	62	Slow sewing	11, 38
· (cover stitch)	29, 67			· standard foot	10	Spare knife	71
· neatening	26			· pressure	20	Special accessories	77
Elastic				· swing-out	16	Spools- positioning	12
· edges with cover stitch	68			· tape guide	61	· replacing	34
· sewing on with overlock	61			Puckering seams	73	Spool pins	8, 12
Electronics/safety	14					Stabilising seams	61

Stitch types		Test sewing	
· chain stitch	28, 29	· chain stitch	55
· 3 thread cover stitch	28, 29	· cover stitch/ top & bottom	51
· 4 thread cover stitch/ top & bottom		· overlock	35
cover stitch	28, 29		
· 5 thread top & bottom	28, 29	U	
· 4 thread overlock	26, 27	Uneven feed	72
· 3 thread overlock	26, 27	Unpicking seams	
· 3 thread super		· chain stitch	55, 66
stretch	26, 27	· cover stitch/ top & bottom	52
· 3 thread roll hem	26, 27	· overlock	56, 66
· 3 thread narrow		Upper knife	
seam	26, 27	· raising/lowering	20
· 2 thread overlock	26, 27	Upper knife arm	
· 2 thread roll hem	26, 27	· raising/lowering	40
· 2 thread wrapped		Upper looper	
overlock	26, 27	· threading	31
Stitch width	17	· release (cover/top & bottom/chain stitch)	39
· 3 thread overlock	19		
Support rod	11	W	
Swing-out foot	16	Waste collector	12
Switch – power/light	14	Wave-free seams in knits	19
T		Wide cutting width	17, 18
Technical Data	76	Wiper	48
Thread		Wiper activating lever	48
· breakage	72	Wiper fine tuning lever	6, 7
· cutter	35	Wiper spool pin	13
· recommendations	23	Wiper tension	48
· replacing	34	Wiper thread	28
Thread ends		Wiper threading	48
· securing	52, 56		
Thread guides			
· C needle	33		
· eyelet	48		
· feeding cast link	48		
· L needle	34		
· R needle	43		
· lower looper	32		
· upper looper	31		
· wiper	48		
Thread guide stand	11		
· assembling	11		
Threading			
· chain stitch	53, 54		
· cover stitch	42–47		
· top & bottom	48		
· 3/4 thread overlock	24, 25		
· 2 thread overlock	24, 25		
· 3 thread super			
stretch	24, 25		
· loopers	31, 32, 42, 53		
· overlock stitches	26, 27		
· preparation	30		
· tips	30		
Thread/needle/fabric	23		
Thread tension	25		
· checking cover stitch			
sewing test	51		
· checking overlock sewing			
test	35		
· fine tuning chain stitch	55		
· fine tuning cover stitch	51		
· fine tuning overlock	35		
· special threads	36		

Technical data

Stitch types

Top & bottom cover stitch:	3 needles	1 wiper	1 looper	5 mm
	2 needles	1 wiper	1 looper	5 mm
	2 needles	1 wiper	1 looper	2.5 mm
Cover stitch:	3 needles	1 looper		5 mm
	2 needles	1 looper		5 mm
	2 needles	1 looper		2.5 mm
Chain stitch:	1 needle	1 looper		
4 thread overlock with integrated safety seam:	2 needles	2 loopers		
3 thread super stretch:	2 needles	1 looper		
3 thread overlock, flatlock, roll hem:	1 needle	2 loopers		
2 thread overlock, flatlock, roll hem:	1 needle	1 looper		

Seam width:	2.5 mm	2 needle cover stitch
	5 mm	3 needle cover stitch 2 needle cover stitch
	3–7 mm	2/3 thread overlock
	5–7 mm	4 thread overlock/3 thread overlock

Stitch length:	1–4 mm
-----------------------	--------

Differential feed:	Pushing effect: N–2 Stretching effect: 0.7–N
---------------------------	---

Presser foot:	Standard foot (swing-out), snap-on sole Cover stitch foot (compensating foot), snap-on sole
----------------------	--

Presser foot lifter:	Two-step. Max. lift 7 mm.
-----------------------------	---------------------------

Integrated accessories:	Roll hemmer, tape guide
--------------------------------	-------------------------

Handwheel:	Rotates forwards (counter-clockwise)
-------------------	--------------------------------------

Needle system:	130/705H (JLx2 can be used if necessary for cover/chain stitch)
-----------------------	--

Electronic needle stop:	Cover stitch/top & bottom	Position F,H generally down
	Chain stitch	Position G, generally down
	Overlock stitches	Positions A–E, generally up

Sewing speed:	Max. 1500 s.p.m. for overlock stitches (Pos. A–E)
	Max. 800 s.p.m. for cover stitch (Pos. F)
	Max. 800 s.p.m. for chain stitch (Pos. G)
	Max. 500 s.p.m. for top&bottom cover stitch (Pos. H)

Safety:	Micro safety switches LED safety control lamps
----------------	---







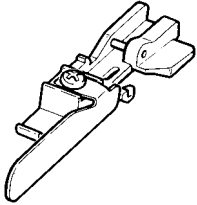

Weight:	2500DCEt 8.8 kg
----------------	-----------------

Dimensions:	335 W x 295 D x 340 H mm
--------------------	--------------------------

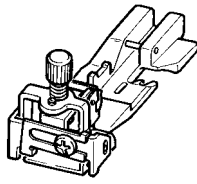
Foot control:	Model Nr. YC-425
----------------------	------------------

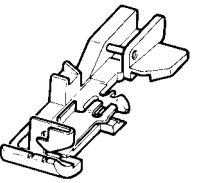
We reserve the right to make changes in the interests of technical progress.

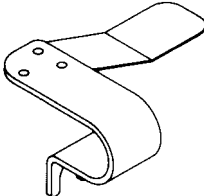
Remove needle R when using these special presser feet

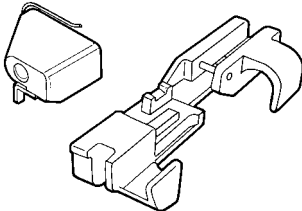
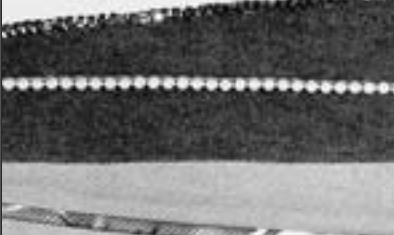
Blind stitch foot		
Elasticator		
Cording foot		
Gathering attachment		
Multi-purpose foot with guide		
Sewing Service Leaflet 16 Blind Stitch Foot	Explains use and applications.	4 pages
Sewing Service Leaflet 17 Cording Foot	Explains use and applications.	4 pages
Sewing Service Leaflet 18 Elasticator	Explains use and applications.	6 pages
Sewing Service Leaflet 23 Gathering Attachment	Explains use and applications.	4 pages
Sewing Service Leaflet 24 Cover and chain stitch	Explains use and applications.	6 pages

BERNINA Publications

BERNINA Sewing Service Leaflets

It is not possible to cover more than the basics of sewing in an instruction manual. However, the creative potential of your BERNINA overlocker and sewing machines is enormous. To help you use your machines to the full, BERNINA regularly publishes sewing literature which covers a multitude of subjects from simple sewing techniques to advanced fashion and craft projects. Ask your BERNINA dealer for details.

Each issue of our Sewing Service Leaflets deals with a particular sewing technique in easy to follow steps. Success is guaranteed!

BERNINA Creative Sewing

BERNINA Creative Sewing, our international sewing magazine, is published twice yearly. Fashion, quick-sew projects, sewing for teenagers and children and crafts all feature on a regular basis. Contributions from around the world with fascinating ideas for working with textiles are included in every issue. Special sewing techniques are described in easy to follow step-by-step photo sequences. We also of course report on new in-house developments as well as interesting news from the sewing market. The Creative Sewing magazine is a real source of inspiration – order your next copy from your BERNINA dealer!

BERNINA Collection

The BERNINA Collection is a range of booklets which deal with the latest sewing trends. Each Collection covers one particular theme with a variety of creative examples. Pattern sheets where appropriate, a wealth of background information, fabric and pattern suggestions, ideas for individual design solutions and tips and tricks of the trade ensure professional results. Comprehensive and fully illustrated instructions for BERNINA sewing machines, overlockers and special presser feet guarantee sewing success. They are published two to three times a year. Ask your BERNINA dealer!



Sollte diese Maschine in ein anderes Sprachgebiet verkauft werden, fordern Sie beim nationalen Importeur oder BERNINA-Händler eine Bedienungsanleitung in der entsprechenden Sprache an.

If this machine has been purchased in a foreign country, please request an instruction manual in your own language from the national Importer or a BERNINA dealer.

Si cette machine est vendue dans une autre région linguistique, demandez à l'importateur national ou à l'agent BERNINA, un manuel d'instructions dans la langue correspondante.

In caso questa macchina fosse venduta in un territorio di lingua diversa si prega di richiedere il libretto d'istruzione nella lingua adeguata presso l'importatore nazionale oppure presso un rivenditore BERNINA.

Si esta máquina se vende en otra región lingüística entonces pida Vd. a su importador nacional o al representante BERNINA un manual de instrucciones en el idioma correspondiente.

Indien deze machine in een ander taalgebied werd gekocht, kunt u bij de nationale importeur of BERNINA vakhandelaar een handleiding in de overeenkomstige taal aanvragen.

Skulle denne maskine blive solgt i et andet sprogområde, bedes du henvende dig hos den nationale BERNINA-importør eller en BERNINA-forhandler, hvor du kan købe en brugsanvisning på den ønskede sprog.

Om den här maskinen har köpts i ett annat land, var vänlig beställ en instruktionsbok på Ditt eget språk från importören eller en BERNINA-återförsäljare.

Er denne maskinen kjøpt i utlandet, kan instruktionsbok bestilles på ditt eget språk fra BERNINA importøren eller nærmeste BERNINA forhandler.

Tarvittaessa voit tiedustella omakielistä käyttöohjekirjaa BERNINA-maahantuojalta tai jälleenmyyjältä.

Se esta máquina foi comprada num país estrangeiro, dever-se-à pedir o manual de instruções naquela ao importador nacional ou ao forneoedor da BERNINA.

ΑΝ Η ΜΗΧΑΝΗ ΕΧΕΙ ΑΓΟΡΑΣΤΕΙ ΣΕ ΜΙΑ ΞΕΝΗ ΧΩΡΑ, ΠΑΡΑΚΑΛΩ ΖΗΤΗΣΤΕ ΕΝΑΝ ΟΔΗΓΟ ΛΕΙΤΟΥΡΓΙΑΣ ΣΤΗΝ ΔΙΚΗ ΣΑΣ ΓΛΩΣΣΑ ΑΠΟ ΤΟΝ ΓΕΝΙΚΟ ΑΝΤΙΠΡΟΣΩΠΟ ΤΗΣ BERNINA Η ΑΠΟ ΤΟΥΣ ΠΩΛΗΤΕΣ ΤΗΣ BERNINA.

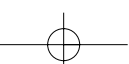

BERNINA® 2500DCET			NL	NC	NR	UL	LL	SSL	SL	CW
A	1	4 thread overlock with integrated safety system	!		•	●	●	▲	2.5	2
	2	3 thread super stretch	!		•	■	●	▲	2.5	1-2
	3	3 thread overlock	!		•	●	●	▲	2.5	2
	4	2 thread wrapped overlock	!		•	■	●	▲	2.5	2
	5	3 thread narrow seam	•		•	●	●	▽	1-1.8	1-2
	6	2 thread roll hem	•		•	■	●	▽	1-1.8	1-2
B	1-6	With woolly nylon or similar decorative threads								
C	7	3 thread roll hem	•		•	●	●	▽	1-1.8	1-2
D	8	3 thread flatlock	!		•	●	●	▲	2.5	2
E	9	2 thread flatlock	!		•	■	●	▲	2.5	2
			NL	NC	NR	W	LL	SSL	SL	CW
F	10	4 thread cover stitch	!				●	▲	3	
	11	3 thread cover stitch	!	•			●	▲	3	
	12	3 thread narrow cover stitch	!				●	▲	3	
G	13	2 thread chain stitch	•	•			●	▲	2.5	
H	14	5 thread top & bottom cover stitch	!			●	●	▲	3-4	
	15	4 thread top & bottom cover stitch	!	•		●	●	▲	3-4	
	16	4 thread narrow top & bottom cover stitch	!		•	●	●	▲	3	

NL = Needle **L**

NC = Needle **C**

NR = Needle **R**

UL = Upper looper

W = Wiper

LL = Lower looper

SSL = Stitch selection lever

SS = Stitch length

CW = Cutting width

Tips:

- Raise the presser foot to release the tensions when threading or knotting on thread.
- Select position «B» for woolly nylon or similar decorative threads.

!	Insert needle L and thread
	Insert needle C and thread
	Insert needle R and thread
!	Thread needle L or C
!	Thread needle L or R
•	Do not thread needle, remove needle/thread
●	Thread the upper looper
●	Thread the lower looper
●	Thread the lower looper
▲	Move stitch selection lever to overlock
▽	Move stitch selection lever to roll hem
	Raise the upper knife and upper knife arm
	Attach the cover stitch extension plate
	Lower the wiper and finger guard
	Press in wiper activating lever

Converting from overlock to cover/chain

1. Turn stitch selection dial to position **F** for cover stitch or **G** for chain stitch.
2. Press the needle stop button to lower the needle clamp.
3. Remove the waste collector and open the looper cover.
4. Switch conversion arm from overlock to cover/chain stitch.
5. Remove the knife guard and attach the cover/chain stitch extension plate.
6. Turn the handwheel to bring the needle clamp to its highest position.
7. Raise the presser foot and swing it out.
8. Raise the upper knife and the upper knife arm.
9. Cut all threads and remove any chain-off.
10. Insert needles in the appropriate cover/chain stitch positions (tools in looper cover).
11. Thread cover/chain stitch looper (purple markings) leaving 8 cm or 3" of thread hanging in the machine. Close the looper cover.
12. Thread cover or chain stitch needles, place threads under the presser foot.
13. Swing back presser foot. Adjust the stitch length and differential feed to suit the stitch and fabric.
14. Sew to the end of the seam, turn the handwheel away from you (clockwise) to raise the needles, lift presser foot, remove work and cut threads.

Converting from cover/chain stitch to overlock

1. Turn the stitch selection dial to desired position, (A–E).
2. Lower the presser foot and press Needle stop to lower the needle clamp.
3. Open looper cover and slide the conversion arm from cover/chain to overlock.
4. Remove the extension plate and replace it with the knife guard.
5. Turn the handwheel to bring needle clamp to highest position.
6. Raise the presser foot and swing it out. Cut all threads and remove any chain-off.
7. Insert overlock needle(s) in the appropriate position for selected stitch (tools in looper cover).
8. Thread overlock looper(s) according to stitch selected.
9. Thread needle(s).
10. Swing presser foot back.
11. Lower the upper knife arm and upper knife if necessary.
12. Close the looper cover and attach the waste collector.
13. Adjust the stitch length, differential feed and cutting width to suit stitch and fabric.
14. Test sew: Place a piece of fabric under the presser foot and needle(s), lower the presser foot. Sew. Continue sewing at the end of the seam until an 8 cm or 3" chain is formed. Cut threads.

Converting from cover stitch position F (4 thread cover stitch) to top & bottom cover stitch (position H)

1. Turn the stitch selection dial to «H».
2. Place a double layer of fabric under the needles and presser foot.
3. Lower the presser foot.
4. Press the needle stop button so that the needles are in their highest position.
5. Press wiper activating lever until it clicks into position.
6. Lower the wiper.
7. Press needle stop button to lower the needles.
8. Switch the power switch to off «O».
9. Bring the thread up from the spool and lay it from the back to the front into the guide.
10. Holding the thread in both hands, thread the first guide located behind the machine head.
11. Take the thread through the groove indicated by arrows on the cover (see diagram).
12. Bring the thread into the guide and eyelet, make sure that the thread is in the tension discs by pulling it firmly with both hands (see diagram).
13. Thread the eyelet of the feeding link (see diagram).
14. Raise the presser foot. Pull the thread over the wiper and in front of the needles and then place it under the presser foot (see diagram).
15. Lower the presser foot and the finger guard.
16. Turn the handwheel towards you one or two revolutions, this will thread the wiper, turn the power switch to on «I», begin sewing.

Converting from top & bottom cover stitch (position H) to cover/chain stitch position F (4 thread cover stitch)

1. Remove wiper thread.
2. Lift finger guard and wiper.
3. The needles are in their highest position.
4. Pull out wiper activating lever until it clicks into position.
5. Turn the stitch selection dial to the desired position (F or G).
6. If position G is selected, remove all needle(s) not in use (only needle R is required).
7. If position F is selected, place a double layer of fabric under the presser foot and needles.
8. Lower the presser foot. Turn the handwheel towards you one or two revolutions, begin sewing.

IMPORTANT:

When cover stitch presser foot (compensating foot) is attached, remove it before converting to overlock.

