

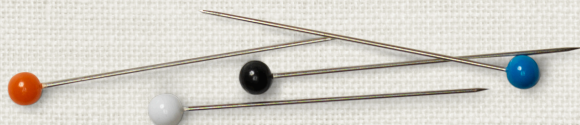

BERNINA 530 | 550 QE



made to create

BERNINA

LOOKING FOR A NEW SEWING PROJECT?

You can find what you want in "inspiration", our sewing magazine. Thanks to great sewing patterns and detailed sewing instructions, every project succeeds right away.

Inspiration magazine
is available in German, English,
French and Dutch



* Not available in all countries.

Dear Bernina Customer,

Congratulations! You've decided on BERNINA, a reliable choice that will delight you for years to come. For over 100 years, our family has placed the highest value on satisfied customers. For myself, it is a matter of personal pride to offer you Swiss precision at the height of perfection, future-oriented sewing technology, and a comprehensive customer service.

5 Series, BERNINA launches three ultramodern models. Apart from the highest demand on technology, we have also focused on the design; after all we sell our products to creative people like you, who expect a high standard of best quality and appreciate the design vocabulary.

Enjoy the creative sewing with BERNINA and find out about our varied range of accessory. Let yourself be inspired by new sewing projects and visit us at www.bernina.com.

And don't forget to make use of service and maintenance offers from our highly trained BERNINA dealers.

I wish you lots of pleasure and many creative hours with your new BERNINA.



H.P. Ueltschi
Owner
BERNINA International AG
CH-8266 Steckborn
www.bernina.com



SAFETY INSTRUCTIONS

IMPORTANT INFORMATION

When using an electrical appliance, basic safety precautions should always be followed, including the following:

Read all instructions before using this sewing computer.

When the sewing computer is not in use, it should be disconnected from the electricity supply by removing the plug from the outlet.

DANGER!

To reduce the risk of electrical shock:

1. The sewing computer should never be left unattended when plugged in.
2. Always unplug the sewing computer from the electrical outlet immediately after using and before cleaning.
3. LED Radiation – Do not view directly with optical instruments. Class 1M LED product.

WARNING!

To reduce the risk of burns, fire, electric shock or injury to persons:

1. Use the sewing computer only for purposes as described in this manual. Use only attachments/accessory recommended by the manufacturer.
2. Do not allow the sewing computer to be used as a toy. Close attention is necessary when this sewing computer is used by or near children and infirm persons. This sewing computer is not intended for use by persons (including children) with reduced physical, sensory or mental capabilities, or lack of experience and knowledge, unless they have been given supervision or instruction concerning use of the sewing computer by a person responsible for their safety. Children must be kept under supervision to ensure that they do not play with the sewing computer.

3. Never operate this sewing computer if:

- it has a damaged cord or plug,
- it is not working properly,
- it has been dropped or damaged,
- it has fallen into water

Take the sewing computer to the nearest authorized BERNINA dealer for examination or repair.

4. Never operate the sewing computer with any air vents blocked. Keep ventilation openings of the sewing computer free from lint, dust and/or fabric bits.
5. Keep fingers away from all moving parts. Special care is required around the sewing needle.
6. Never drop or insert any objects into any opening on the sewing computer.
7. Do not use the sewing computer outdoors.
8. Do not operate the sewing computer where aerosol products (spray) or oxygen is being administered.
9. Do not pull or push the fabric while stitching. This may deflect the needle, causing it to break.
10. Do not use bent needles.
11. Always use the original BERNINA stitch plate. The wrong stitch plate can cause needle breakage.
12. To disconnect, turn power switch to «0» (off), then remove the plug from the outlet. Do not unplug by pulling the cord, instead grasp the plug to pull it from the outlet.
13. Turn power switch to «0» (off) when making any adjustments in the needle area, such as changing the needle or the presser foot, etc.
14. Always unplug the sewing computer from the electrical outlet when carrying out cleaning or maintenance work or any other user servicing adjustments mentioned in this manual.
15. This sewing computer is provided with double insulation (except USA and Canada). Use only genuine replacement parts. Please note the advice on the servicing of double-insulated products.

SERVICING DOUBLE-INSULATED PRODUCTS

In a double-insulated product, two systems of insulation are provided instead of grounding. No grounding means is provided on a double-insulated product nor should a means for grounded be added to the product. Servicing a double-insulated product requires extreme care and knowledge of the system and should only be done by qualified service personnel. Replacement parts for a double-insulated product must be identical to the original parts in the product.

The symbol  may also be marked on the product.

DISCLAIMER

No liability will be assumed for any possible damage which arises from misuse of this sewing computer.

This sewing computer is intended for household use only.

This sewing computer meets the European Standard 2004/108/EC concerning the electromagnetic tolerance.

SAVE THESE INSTRUCTIONS!



Please find the latest version of your instruction manual at www.bernina.com

Environmental Protection



BERNINA is committed to the protection of the environment. We strive to minimize the environmental impact of our products by continuously improving product design and our technology of manufacturing.

When your sewing computer won't be used anymore, dispose this product in an environmentally responsible way according to the national directive. Do not throw away this product with your household waste. In case of doubt, please contact your BERNINA dealer.



If the sewing computer is stored in a cold room, it should be brought to a warm room about one hour before use.

Accessory	7
Preparation	10
<ul style="list-style-type: none"> ■ Overview sewing computer 10 ■ Sewing preparation 12 	
Functions	26
<ul style="list-style-type: none"> ■ «Function»-buttons sewing computer 26 ■ Overview Display 30 ■ Setup Program 32 ■ Tutorial 34 ■ Creative consultant 35 ■ Balance 36 	
Sewing stitches	37
<ul style="list-style-type: none"> ■ Practical stitches 37 ■ Buttonholes 51 ■ Decorative stitches 62 ■ Quilt stitches 63 ■ BSR 66 ■ Alphabets 70 ■ Combi mode 71 	
Cleaning	75
Troubleshooting	76
Stitch patterns	78
Index	86



DANGER!
Very important!
Risk of injury!

DANGER!
Very important!
Risk of damage!



Tips!

- * **Not** supplied as standard with the BERNINA 530
- ** **Not** supplied as standard with the BERNINA 550 QE

Glossary

Balance	Correcting abnormalities in stitch formation due to the fabric
Fabric fold	Folded edge of material
BSR	BERNINA Stitch Regulator. Quilting with consistent stitch length within certain speed
clr	Deleting settings or data
Hook	«Catches» the needle-thread loop, forming the stitch together with the lower thread
LMS	Length Measuring System for buttonhole
Memory	Long Term Memory
Satin stitching	Dense zig-zag
Bartack	Buttonhole-bead cross-connections

All rights reserved

For technical and product improvement reasons, the sewing computer's features, parts and accessories are subject to unannounced changes and alterations at any time. The accessories included can differ from country to country.

Standard Accessory



- Carrier bag
- Accessories box
- Foot control
- Power cable
- Slide-on table
- Seam Guide
- Free Hand System (FHS)

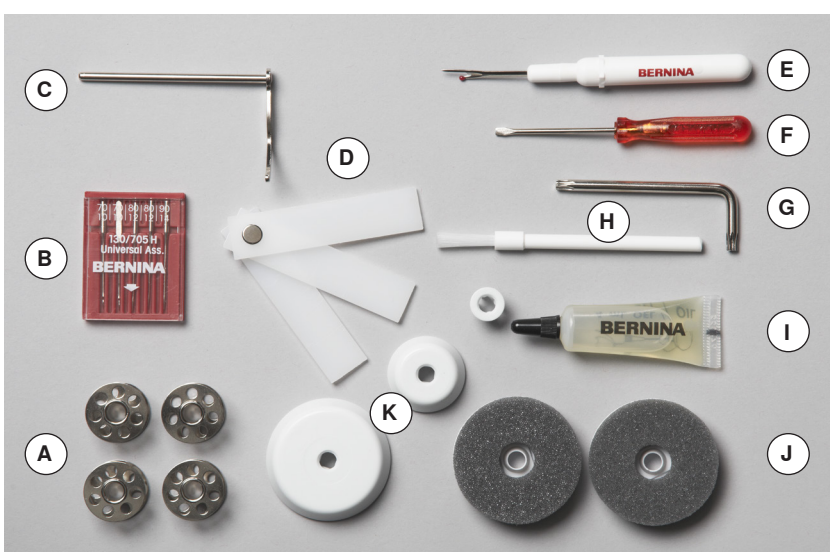

- A** 5 bobbins (one of them in the bobbin case)
- B** Selection of needles
- C** Seam guide, right
- D** Height compensation tool
- E** Seam ripper
- F** Screwdriver, red
- G** Angular Torx wrench
- H** Lint brush
- I** Lubricator
- J** 2 foam pads
- K** 3 spool discs

Presser foot shank and soles (BERNINA 530/550 QE)

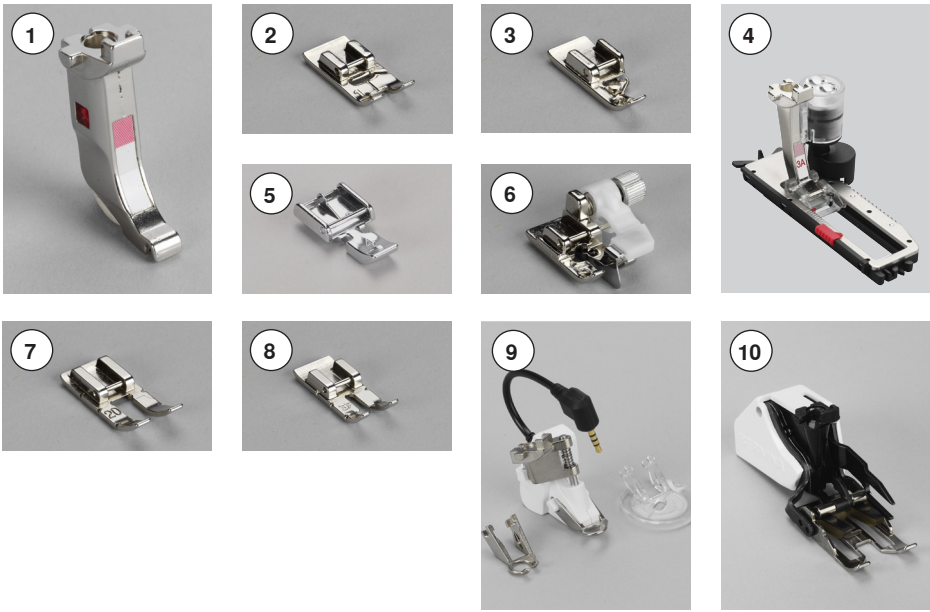

- 1 Presser foot shank
- 2 No. 1 Reverse pattern sole
- 3 No. 2 Overlock sole **
- 4 No. 3A Automatic buttonhole foot with slide
- 5 No. 4 Zipper sole
- 6 No. 5 Blindstitch sole
- 7 No. 20 Open embroidery sole *
- 8 No. 37 Patchwork sole *
- 9 No. 42 BSR foot *
- 10 No. 50 Walking foot *

Presser feet (BERNINA 550 QE)

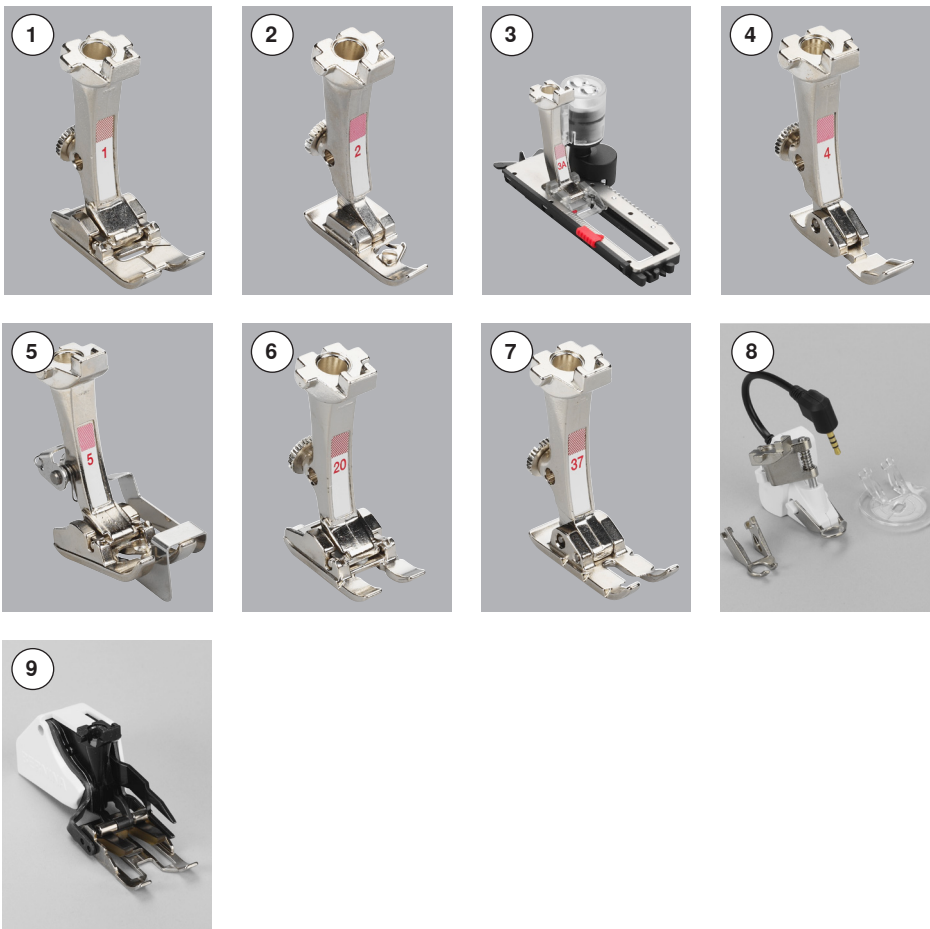

- 1 No. 1 Reverse pattern foot
- 2 No. 2 Overlock foot **
- 3 No. 3A Automatic buttonhole foot with slide
- 4 No. 4 Zipper foot
- 5 No. 5 Blindstitch foot
- 6 No. 20 Open embroidery foot
- 7 No. 37 Patchwork foot
- 8 No. 42 BSR foot
- 9 No. 50 Walking foot

Visit www.bernina.com for more accessory information.

The presser foot system can vary depending on the market (presser feet or presser foot shank and soles).

Accessory box



Storing accessory

- on the back of the box, pull both extensions out until they click into place

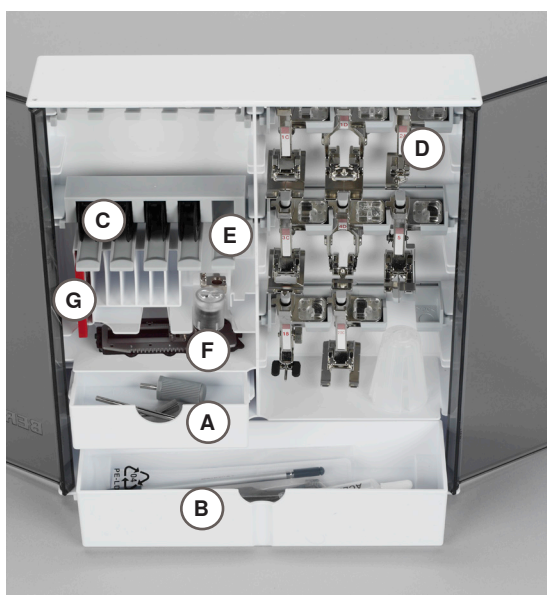

Storage example

The box is equipped as standard with one small **A** and one large **B** drawer as well as a compartment for bobbin holders **C** and presser feet **D**.

- to remove a bobbin, press the compartment holder **E** lightly
- buttonhole foot with slide no. 3A can be stored in the left compartment **F**
- store the needle range supplied in the special compartment **G**



All rights reserved

For technical and product improvement reasons, the sewing computer's features, parts and accessory are subject to unannounced changes and alterations at any time. The accessory included can differ from country to country.

Front view

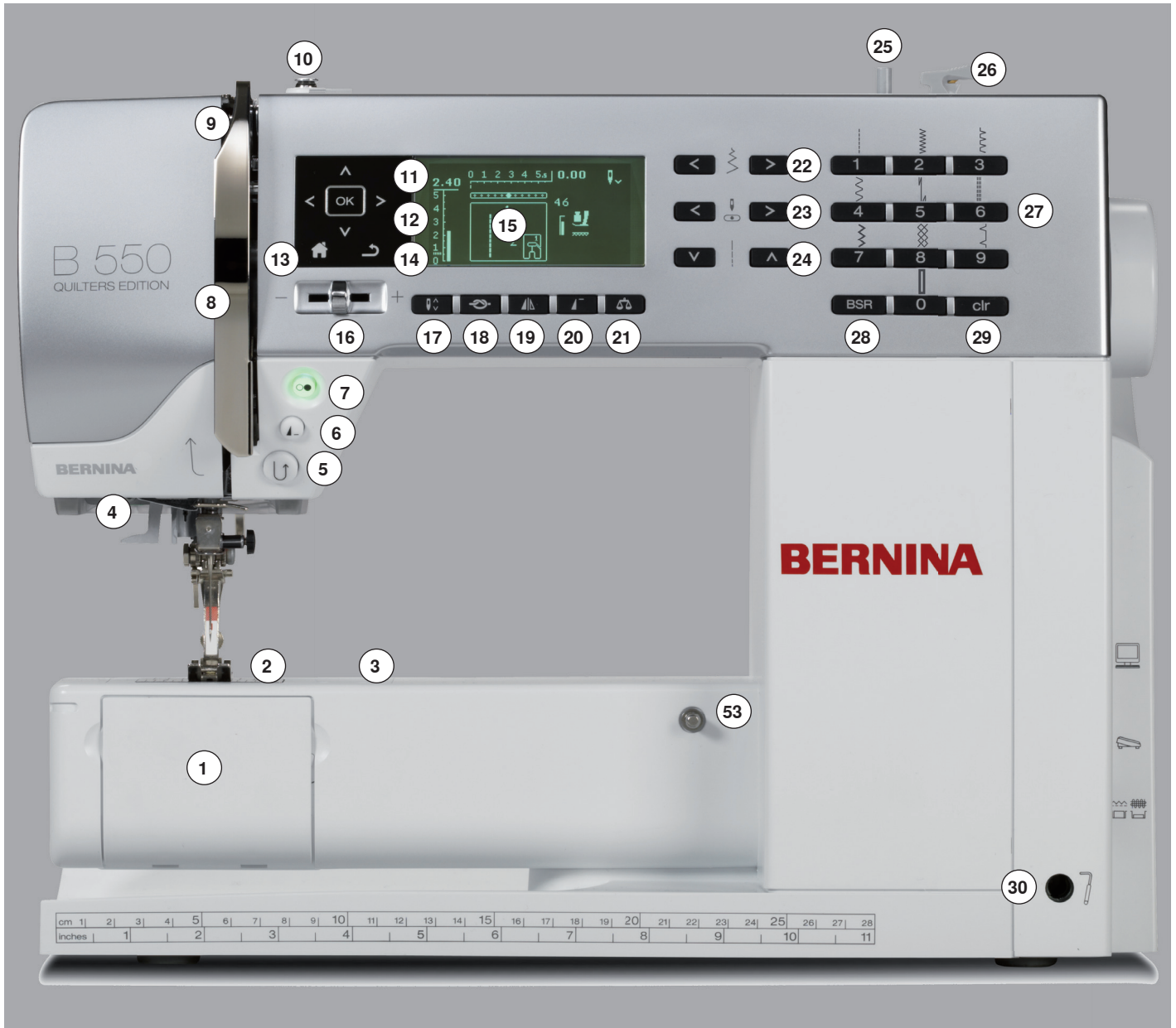

Detail view

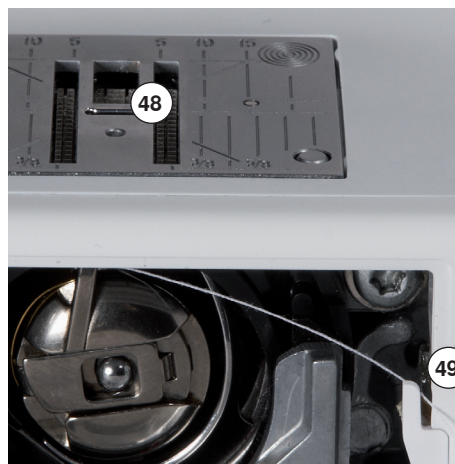
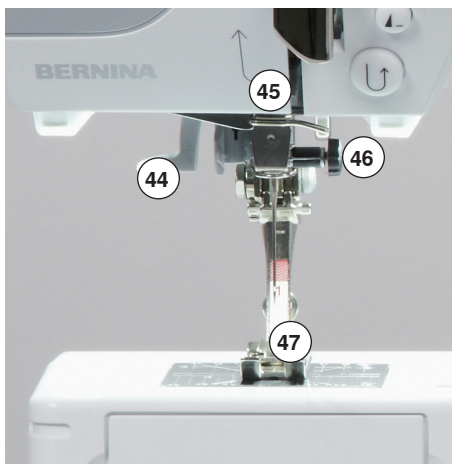



- | | |
|--|---|
| 1 Bobbin cover | 37 Handwheel |
| 2 Stitch plate | 38 PC-Connection for software update |
| 3 Attachment base for special accessories | 39 Foot control socket |
| 4 LED sewing light | 40 Feed dog drop |
| 5 «Quick reverse»-button | 41 Power switch |
| 6 «Pattern end/pattern repeat»-button | On «I»/Off «0» |
| 7 «Start/Stop»-button | 42 Power plug socket |
| 8 Thread take-up cover | 43 Air vents |
| 9 Thread take-up lever | 44 Needle threader |
| 10 Bobbin winder pre-tension | 45 Thread guide |
| 11 «Navigation»-buttons left/right/down/up | 46 Needle clamp |
| 12 «OK»-button | 47 Presser foot |
| 13 «Home»-button | 48 Feed dog |
| 14 «Back»-button | 49 Thread cutter in hook opening |
| 15 Display | 50 Presser foot pressure adjustment wheel |
| 16 Speed control | 51 Headframe fixing screw |
| 17 «Needle stop»-button down/up | 52 Thread cutter on the headframe |
| 18 «Securing»-button | 53 Slide-on table socket |
| 19 «Mirror image»-button | 54 Darning hoop connection |
| 20 «Pattern begin»-button | 55 Presser foot lifter |
| 21 «Balance»-button | 56 BSR-connection |
| 22 «Stitch width»-buttons | |
| 23 «Needle position»-buttons | |
| 24 «Stitch length»-buttons | |
| 25 Bobbin winder device | |
| 26 Thread cutter on bobbin winder | |
| 27 «Stitch selection»-buttons | |
| 28 «BSR»-button | |
| 29 «clr»-button | |
| 30 Free hand system connection | |
| 31 Thread tension adjustment wheel | |
| 32 Rear thread guide | |
| 33 Carrying handle | |
| 34 Vertical spool pin | |
| 35 Horizontal spool pin | |
| 36 Eyelet thread guide | |



USA/Canada only: The sewing computer has a polarized plug (one blade wider than the other). To reduce the risk of electrical shock, this plug is intended to fit in a polarized outlet only one way. If the plug does not fit fully in the outlet, reverse the plug. If it still does not fit, contact a qualified electrician to install the proper outlet. Do not modify the plug in any way!

Foot control



Before beginning to sew

- unwind the cable
- plug the cable in the outlet provided **A**
- unwind the cable to the desired length and slip into **B** or **C**

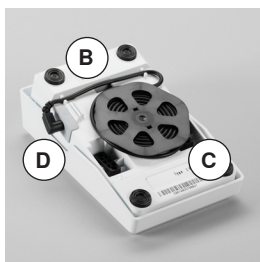

Sewing speed control

Control the sewing speed by pressing the foot control more or less.

Adjust needle down or up

- adjust the down/up position of the needle by sinking the heel back on the foot control

After sewing

- wind the cable around the spool
- plug cable into **D**



USA/Canada only: Use only foot controller type LV-1 with sewing computer B 530 and B 550 QE.

Slide-on table

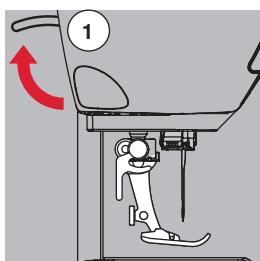

- turn the handwheel (see page 11)
- ▶ needle is raised
- raise presser foot lifter **1** up
- ▶ presser foot is lifted



The slide-on table increases sewing surface.

Attaching the slide-on table

- raise the needle and presser foot
- slide over free-arm to the right until it engages

Removing the slide-on table

- raise the needle and presser foot
- press button **A** down
- pull slide-on table to the left



Seam Guide

- press the release button and insert into the groove (underside of table) from left or right
- Can be moved over the entire table length.

Free Hand System (FHS)



The FHS raises and lowers the presser foot.

Attaching the lifter

- insert into the opening

Raising and lowering the presser foot

- with your knee push lever to the right

You should be able to operate the FHS with your knee in your normal sitting position.

- ▶ the presser foot is raised; the feed dog is lowered simultaneously. The thread tension is released

The feed dog is raised as soon as the first stitch is sewn.



Your dealer can adjust the FHS if necessary.

Vertical spool pin

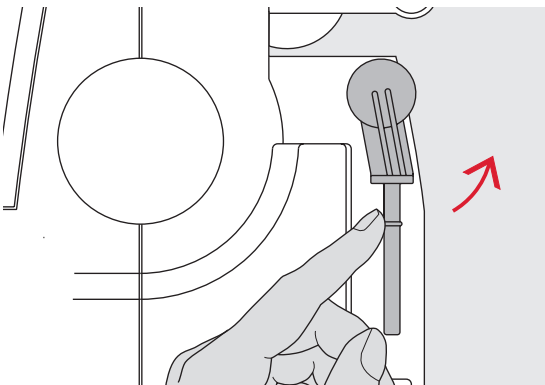

The vertical spool pin is on the side behind the handwheel.

It is an essential aid for sewing with more than one thread, i.e. double needle work and can also be used for winding the bobbin while sewing.

- turn the spool pin as far it will go

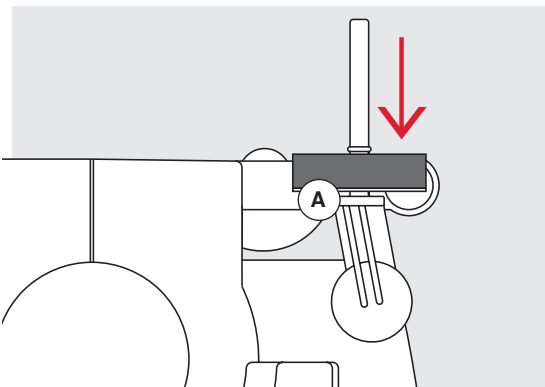

- when using all reels, add the foam pad **A** for stability

Winding a bobbin

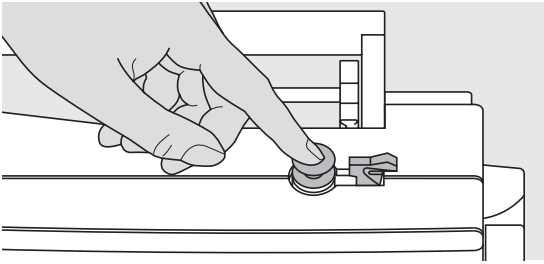

- turn power switch to «I»
- place empty bobbin on spindle

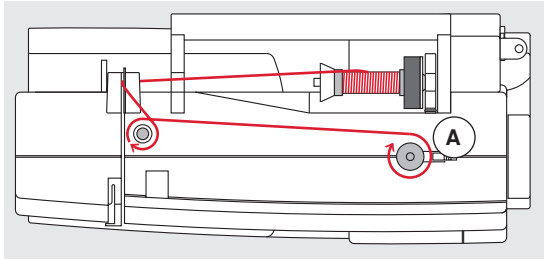

- place foam pad on the spool pin
- place thread on the spool pin
- attach appropriate spool disc
- following the direction of the arrow, take thread through the rear guide and round the pre-tension stud
- wind the thread two to three times around the empty bobbin
- cut off any excess thread on the thread cutter **A**



Appropriate spool disc

Diameter of thread spool determines disc size, there must be no gap between the disc and the spool.

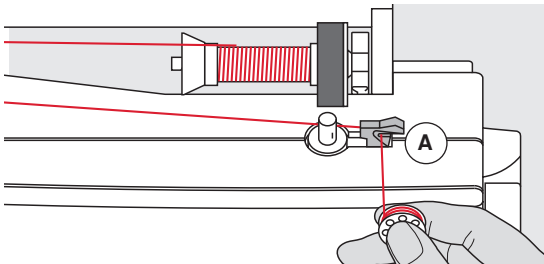

- push engaging lever **A** against bobbin
- ▶ the winder works automatically
- ▶ the motor will stop automatically when the bobbin is full
- remove bobbin and
- pull the thread over thread cutter **A** to cut it

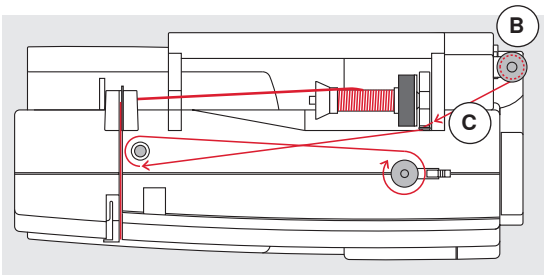

Bobbin winding while sewing

- attach foam pad on the vertical spool pin **B**
- place thread on the vertical spool pin
- following the direction of the arrow, take thread through the thread guide **C** and
- guide around the pre-tension stud

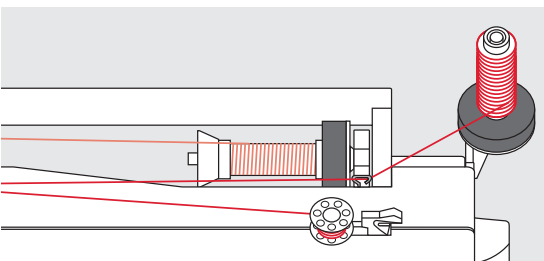

Then proceed as mentioned above.

Inserting a bobbin/Threading lower thread

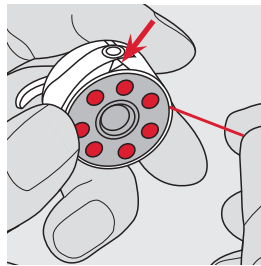
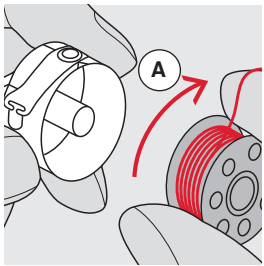

- insert the bobbin so that the thread runs clockwise **A**
- pull the thread from the right into the slot

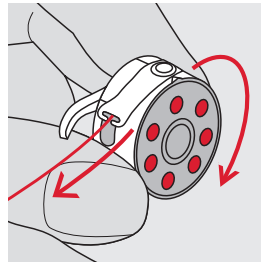
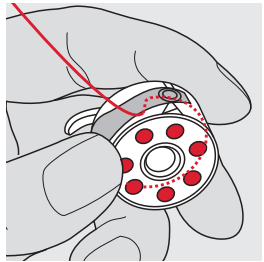

- pull the thread to the left under the spring
- until it lies in the T-shaped slit at the end of the spring
- pull the thread
 - ▶ the bobbin must turn clockwise

Exchanging bobbin case

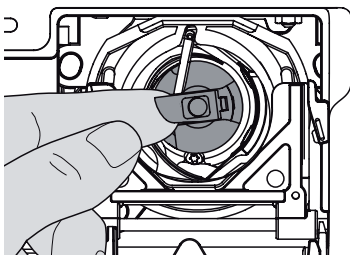

Remove the bobbin case

- raise needle
- turn power switch to «0» (off)
- open bobbin cover
- grasp the latch of the bobbin case
- remove bobbin case

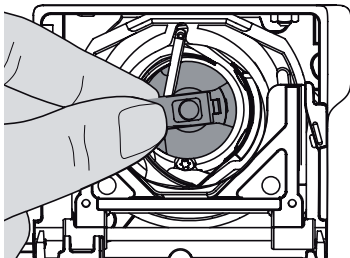

Insert the bobbin case

- hold the bobbin case latch
- Finger of the bobbin case **A** points upwards.
- insert the case so that it clicks into place

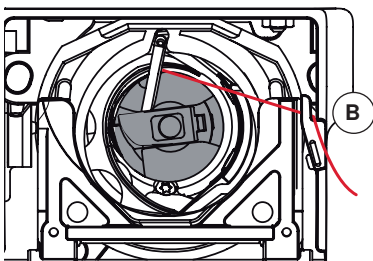
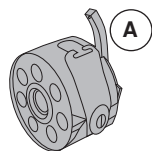

Bobbin thread cutter

- pull the thread over cutter **B** to cut it
- close the bobbin cover



The bobbin thread does not have to be brought up as the loose end is just the right length to start sewing.

Threading the upper thread

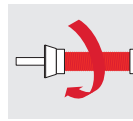

- raise the needle and presser foot
- turn power switch to «0» (off)
- place foam pad on pin base
- place spool on pin so that the thread unwinds clockwise
- attach appropriate spool disc

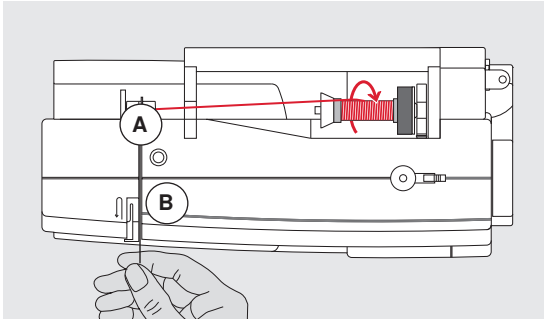

- take thread through rear guide **A**
- then into slit of upper thread tension **B**

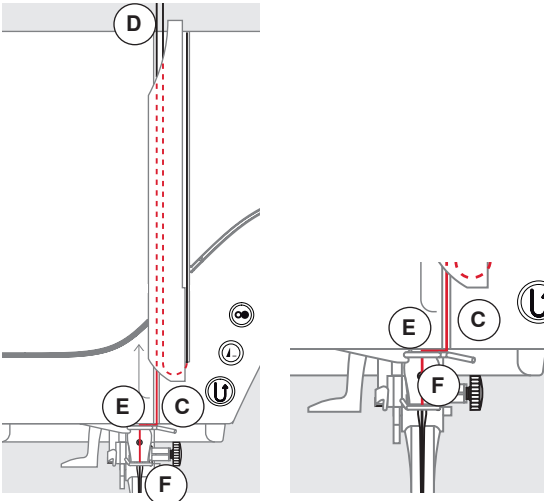

- pull thread down to the right of the take-up cover and around **C**
- take thread up to the left of the cover and around **D**, placing it in the take-up lever
- take thread down and through guides **E** and **F**
- thread the needle (see page 18)



Appropriate spool disc

Diameter of thread spool determines disc size, there must be no gap between the disc and the spool.

Changing the needle

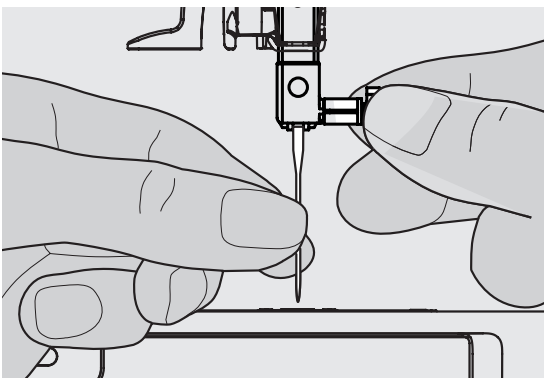

Removing the needle

- raise needle
- lower or remove presser foot (see page 12)
- turn power switch to «0» (off)
- loosen the needle clamp screw
- pull the needle down to remove

Inserting the needle

- flat side of needle to the back
- insert the needle as far as it will go
- tighten the needle clamp screw

Threading the double needle

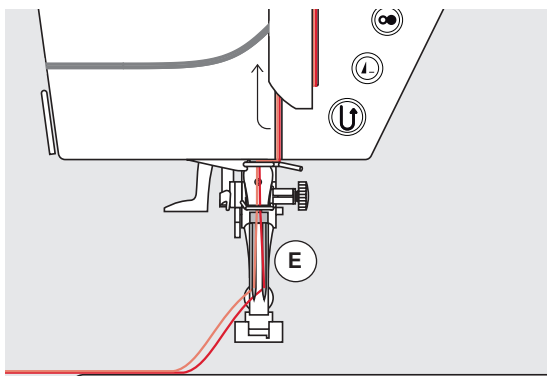
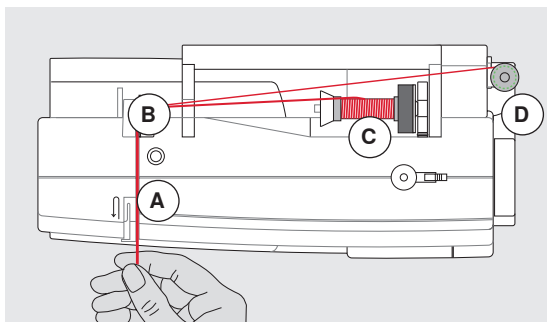

Threading the first thread

- turn power switch to «0» (off)
- insert double needle
- raise the needle and presser foot
- place foam pad on pin base
- place thread spool **C** on horizontal spool pin
- attach appropriate spool disc
- take thread through rear guide **B**
- guide the thread to the front in the slit and past the tension disc **A** on the **right** side
- guide the thread to the needle as usual and
- thread the **right** needle manually

Threading the second thread

- place foam pad on vertical spool pin
 - place the second thread spool **D** on the vertical spool pin
 - take thread through rear guide **B**
 - guide the thread to the front in the slit and past the tension disc **A** on the **left** side
 - guide the thread to the needle as usual and
 - thread the **left** needle manually
- Threads **E** must not be twisted together.



When using the vertical spool pin, always add a foam pad.

Threading the triple needle

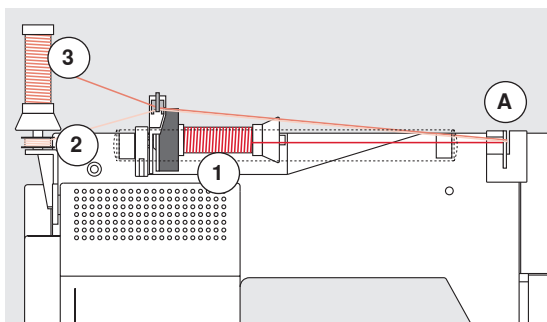

Two thread spools and one full bobbin are needed.

- insert triple needle
- place one thread spool **1** on horizontal spool pin
- place second thread spool **3** and the bobbin **2**, separated by a spool disc, on vertical spool pin (both spools must to turn in the same direction)
- thread as usual and
- guide **two** threads on the **left** side of the tension disc **A** and **one** thread past the **right** side
- guide threads to the needle as usual
- and thread every needle manually



The thread deduction of the superimposed thread spools can be improved by the additional eyelet for metallic and silk threads (optional accessory).

Thread needle

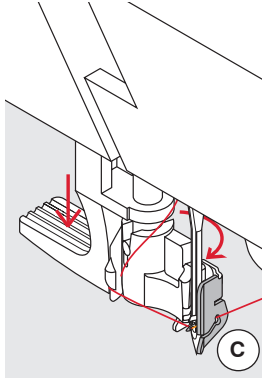
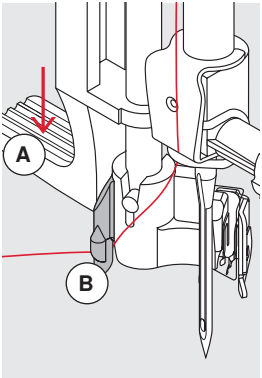

Position the needle upper by pressing the foot control once (1 stitch).

- raise needle
 - lower presser foot
 - turn power switch to «0» (off)
 - hold thread to the left and back
 - press lever **A** down and hold it
 - guide thread around the hook **B** to the right in front of the needle
- put the thread from the front into the guide **C** until it catches in the wire hook

- release lever **A**
- ▶ needle is threaded
- pull the thread to the back and

- put the thread under the foot and pull it from front to back over the thread cutter on left side of the head frame **D**, cut
- Threads release automatically as soon as the first stitch is sewn.

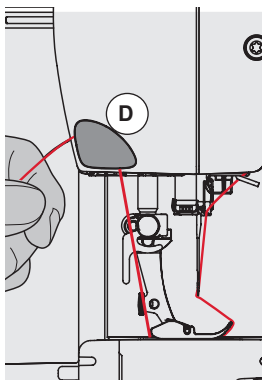
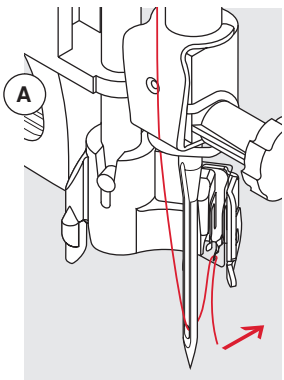

Changing the presser foot sole

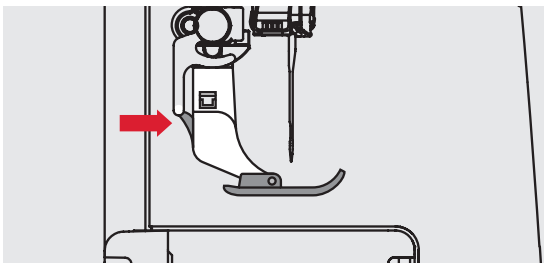

Remove presser foot sole

- raise the needle and presser foot
- turn power switch to «0» (off)
- press the button on the shaft
- ▶ the sole is released

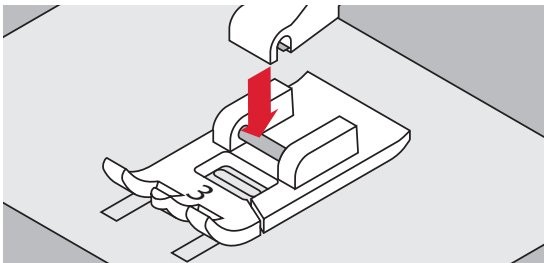

Attaching the presser foot sole

- place the presser foot sole under the shaft
- the peg sits under the opening of the shaft

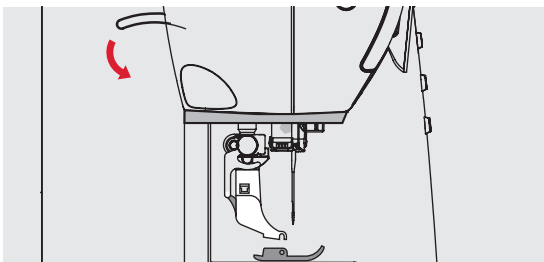

- lower the presser foot lifter
- ▶ the foot sole will click into position

Changing the presser foot

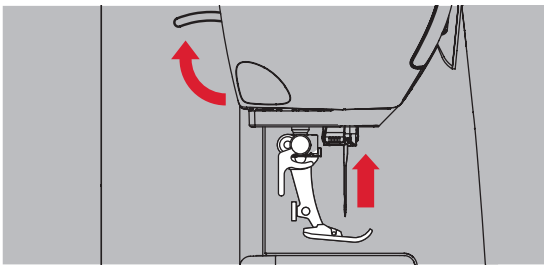

Remove presser foot

- raise the needle and presser foot
- turn power switch to «0» (off)

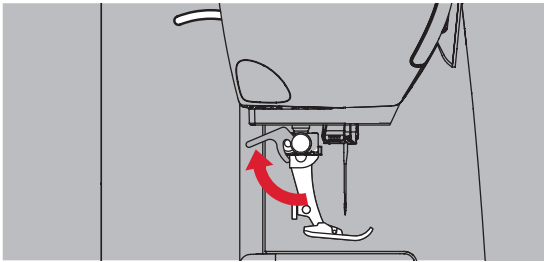

- raise the clamping lever
- remove the presser foot

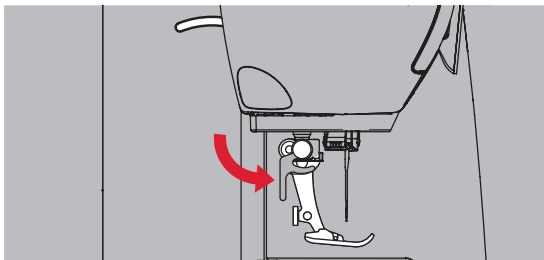

Attaching the presser foot

- guide the foot upwards over the cone
- press the clamping lever down

Stitch plate

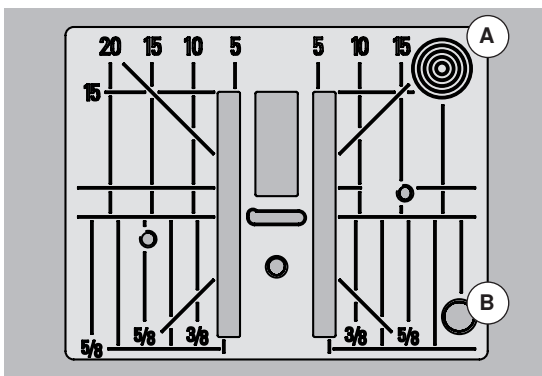

Stitch plate markings

- the stitch plate is marked with vertical, horizontal and diagonal lines in **mm** and **inches**
- the lines help to guide the fabric for sewing seams and precise topstitching, etc.
- the horizontal markings are helpful for sewing corners and buttonholes, etc.
- the diagonal markings are useful for quilting
- needle insertion point is position «0» (center needle position)
- the vertical measurements correspond to the distance between the needle and the line
- the measurements are marked to the right and left, measuring from the center needle position

Remove the stitch plate

- press «Feed dog»-button (see page 11)
- ▶ the feed dog is lowered
- turn power switch to «0» (off)
- remove presser foot and needle
- press the stitch plate down at the right back corner **A** until it flips up
- remove the stitch plate

Replace the stitch plate

- place the stitch plate over the opening **B**
- press down until it clicks into place
- press «Feed dog»-button
- ▶ the feed dog is raised as soon as the first stitch is sewn

Thread tension

The upper thread tension is set optimally at the BERNINA factory and the sewing computer has been tested. Metrosene-/Seralon thread size 100/2 (Company Mettler, Switzerland) are used for upper and lower thread.

In case of using other types of sewing or embroidery threads, the optimal tension may vary. Therefore it may be necessary to adjust the tension to suit the fabric and the desired stitch pattern.

For example:

	Tension	Needle
Metallic thread	approx. 3	90
Monofilament thread	approx. 2-4	80

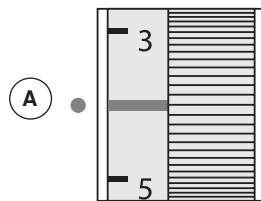

The basic setting

- is indicated when the red line on the tension adjustment wheel is in line with the marking **A**
- the thread tension needn't be altered when sewing standard fabric
- for special fabric, the tension can be adjusted by turning the tension adjustment wheel to suit the material

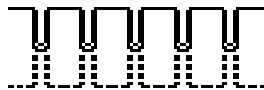

Perfect Stitch Formation

The interlooping of the threads is in the material.



Upper thread tension too tight

The lower thread is pulled more up, i.e. to the right side of the material.

- to reduce the upper thread tension = turn tension adjustment wheel to 3-1



Upper thread tension too loose

The upper thread is pulled more down, i.e. to the wrong side of the material.

- to increase the upper thread tension = turn tension adjustment wheel to 5-10

Adjusting presser foot pressure

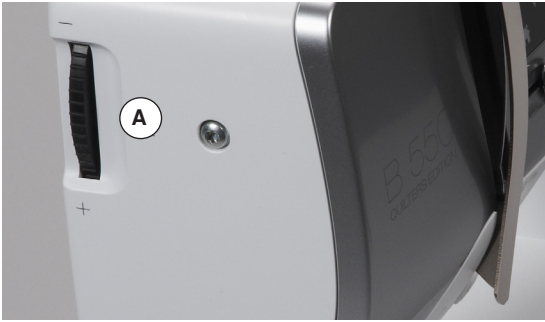

The presser foot pressure is adjusted by the presser foot pressure adjustment wheel **A** on the left side of the headframe.

Presser foot pressure

Basic setting = 46

- ▶ the basic setting is always visible
- for basic fabric

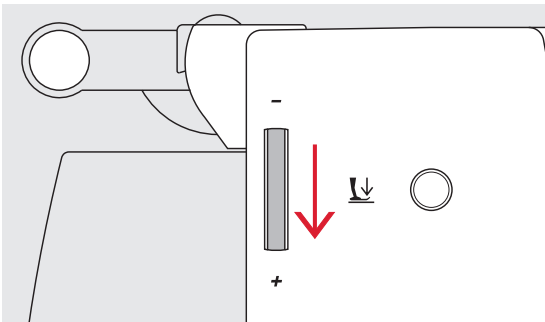

Increase presser foot pressure

- for sturdy material e.g. denim
- improves the fabric feed

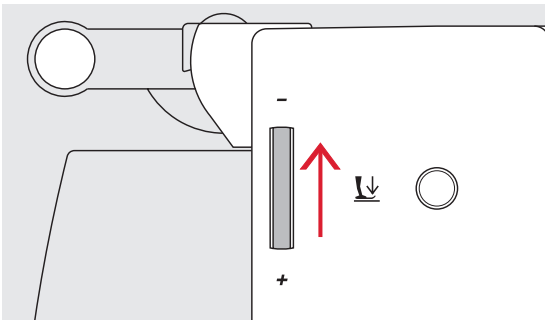

Loosen presser foot pressure

- for jersey fabrics and loose knits
- to prevent fabric from stretching
- adjust pressure so that the fabric still feeds correctly

Feed dog

Feed dog lowered/ready to sew

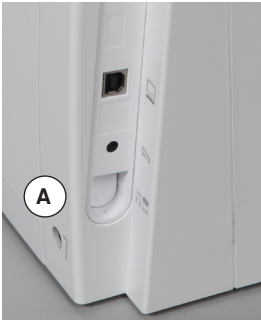

«Feed dog»-button **A** flush with housing.
▶ feed dog is ready to sew

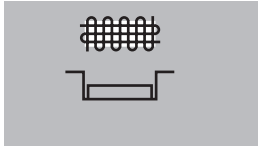

«Feed dog»-button **A** pressed.
▶ feed dog is lowered
For free-motion sewing (darning, embroidery, quilting, etc.).

Feed dog and fabric feed

With each stitch the feed dog moves forward by one step. The length of this step is determined by the stitch length selected.

With an extremely short stitch length, the steps are also very short. The fabric moves away from the foot quite slowly, even at full sewing speed. e.g. button-holes, satin stitch and decorative stitches are all sewn with a very short stitch length.

Let the fabric feed evenly.

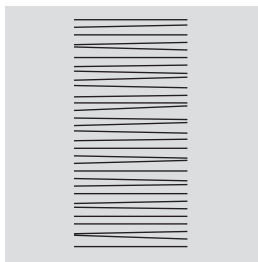
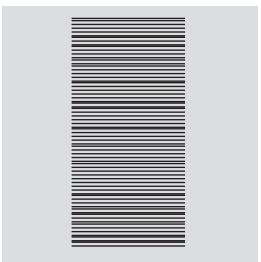
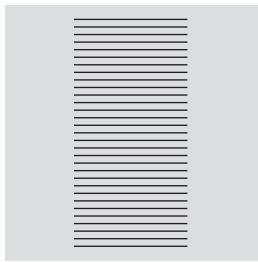

ATTENTION!

Pulling, pushing or holding back the fabric can result in damages of the needle and stitch plate.

Pulling, pushing or holding back the fabric will result in uneven stitches.

Important facts about thread and needle

Thread

The thread is chosen according to use. For a perfect sewing result, thread and fabric quality play an important role. It is recommended to use quality brands.

Cotton thread

- cotton thread has the advantage of being a natural fiber and therefore is especially suitable for sewing cotton fabrics
- if cotton thread is mercerized, it has a slight sheen that is not lost with washing

Polyester thread

- polyester thread has a high tensile strength and is particularly colorfast
- polyester thread is more flexible and is recommended where a strong and elastic seam is required

Rayon threads

- rayon threads are made of natural fibers and have a brilliant sheen
- rayon threads are suitable for decorative stitches and achieve a more beautiful effect

Needle, thread and material

ATTENTION!

Check the needle condition.

As a guideline: Replace the needle before starting a new sewing project. A defective needle does not only damage the sewing project but also the sewing computer.

Care must be taken when choosing needle and thread.

The correct needle size depends on the selected thread and fabric. The fabric weight and type determine the thread weight, needle size and point form.

Needles, threads

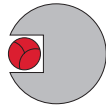

Correct needle/thread combination

When sewing, the thread should travel smoothly down the long groove on the front of the needle.



Too thin thread or too thick needle

The thread has too much clearance in the long groove. Skipped stitches and damage to the thread can occur.

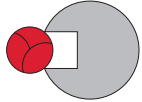

Too thick thread or too fine needle

The thread rubs on the edges of the long groove and can get jammed. This can cause thread breakage.



Guidelines





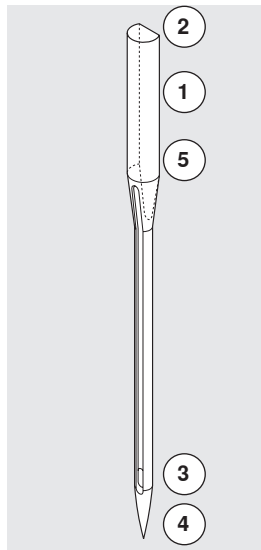



Material and thread	Needle size
Light materials: Fine thread (darning thread, embroidery thread)	70-75
Medium materials: Sewing thread	80-90
Heavy materials: Sewing thread (quilting thread, topstitching)	100, 110, 120

130/705 H-S/70

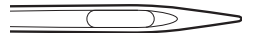
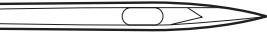

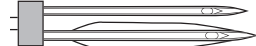
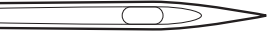
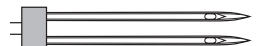
- 1 **130** Shank length
- 2 **705** Flat shank
- 3 **H** Needle scarf
- 4 **S** Needle point (here e.g. medium ball point)
- 5 **70** Needle size (shank diameter)

Overview needles

<p>Universal 130/705 H/60-100</p>  <p>Normal point, slightly rounded</p> <p>For nearly all natural and synthetic fabrics (woven and knitted)</p>	<p>Metafil 130/705 H-MET/75-80 or H-SUK/90-100</p>  <p>Large eye</p> <p>Sewing with metallic threads</p>
<p>Jersey/Stretch 130/705 H-S, H-SES, H-SUK/70-90</p>  <p>Ball point</p> <p>Jersey, knit and stretch material</p>	<p>Cordonnet (Topstitching) 130/705 H-N/80-100</p>  <p>Small ball point, long eye</p> <p>Topstitching with thick thread</p>
<p>Leather 130/705 H-LL, H-LR/90-100</p>  <p>With cutting point</p> <p>All types of leather, synthetic leather, plastic, sheeting</p>	<p>Wing needle (hemstitch needle) 130/705 HO/100-120</p>  <p>Wide needle (wing)</p> <p>Hemstitching</p>
<p>Jeans 130/705 H-J/80-110</p>  <p>Very fine sharp point</p> <p>Heavy weight fabrics such as jeans, canvas, overalls</p>	<p>Double wing needle 130/705 H-ZWI-HO/100</p>  <p>Special effects with hemstitch embroidery</p>
<p>Microtex 130/705 H-M/60-90</p>  <p>Especially fine sharp point</p> <p>Micro fiber fabrics and silk</p>	<p>Double needle 130/705 H-ZWI/70-100</p>  <p>Needle distance: 1.0/1.6/2.0/2.5/3.0/4.0</p> <p>Visible hems in stretch fabrics, pintucks, decorative sewing</p>
<p>Quilting 130/705 H-Q/75-90</p>  <p>Fine sharp point</p> <p>Straight and topstitching</p>	<p>Triple needle 130/705 H-DR1/80</p>  <p>Needle distance: 3.0</p> <p>Visible hems in stretch fabrics, pintucks, decorative sewing</p>
<p>Embroidery H-SUK/70-90</p>  <p>Large eye, slight ball point</p> <p>Embroidery on all natural and synthetic fabrics</p>	

Overview «Function»-buttons sewing computer



Stitch selection

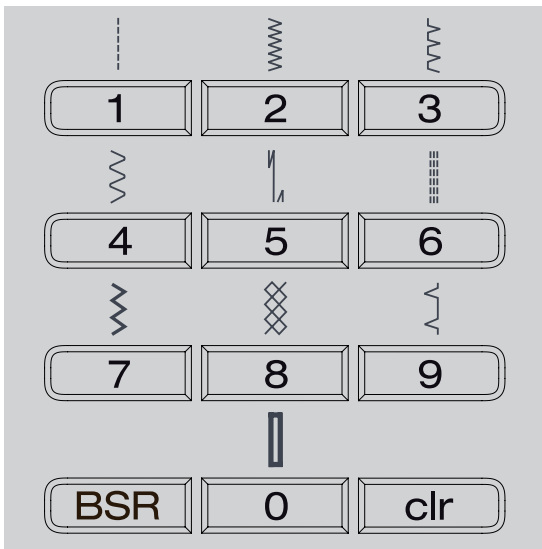

«Direct-selection»-buttons

- select the desired stitch pattern via the «Direct-selection»-buttons
 - ▶ stitch pattern, stitch number, stitch length and width are all visible on the display
- The «Direct selection»-button 0 selects stitch number 51 (standard buttonhole).

Stitch categories

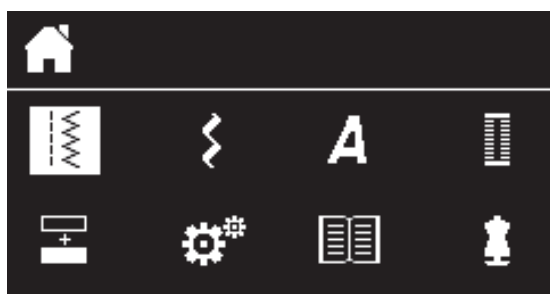

- press «Home»-button
- choose the desired stitch category in the main menu via the «Navigation»-buttons (see page 29)
- confirm by pressing the «OK»-button

Adjusting individually

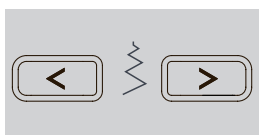

Altering stitch width

- press the left button
- ▶ narrows the stitch width
- press the right button
- ▶ widens the stitch width
- keep button pressed
- ▶ quick alteration

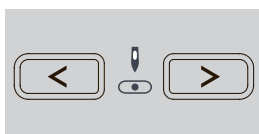

Altering needle position

- press the left button
- ▶ needle moves to the left
- press the right button
- ▶ needle moves to the right
- keep button pressed
- ▶ quick alteration

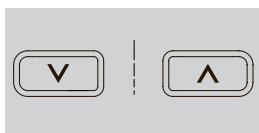

Altering stitch length

- press the left button
- ▶ shortens the stitch length
- press the right button
- ▶ elongates the stitch length
- keep button pressed
- ▶ quick alteration

«Function»-buttons sewing computer



Overview «Function»-buttons



«Quick reverse»-button temporary:

- press the button
- the sewing computer sews stitch pattern in reverse until button is released

Application:

- programs buttonhole length
- programs darning length
- for switching when in the straight stitch securing program no. 5
- manual securing (seam begin and end)
- used for securing in quilters securing program no. 1324

continuous reverse:

- press the button at hold until you hear a beep and
 - ▶ the symbol appears on the display
 - ▶ the sewing computer sews the chosen stitch in reverse
- finish reverse sewing: press button at hold until you hear a beep
 - ▶ the symbol disappears from display



«Pattern end/pattern repeat»-button

- press button while sewing
 - ▶ the sewing computer stops at the end of the active single pattern or the active pattern in a pattern combination (in Memory)
- press the button 1-9x before sewing
 - ▶ the pattern end symbol appears on the display along with the set number of repeats selected

A single pattern or a pattern combination sews out the number of repeats set.



«Start/Stop»-button

- starts and stops the sewing computer when operating it **with** and **without** foot control
- starts and stops the BSR-Function if the BSR foot is attached and activated

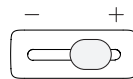

Slide speed control

- with the slide of the Slide Speed Control the sewing speed can be regulated infinitely variable
- while winding the bobbin thread, the speed of the bobbin winder can be regulated if the sewing computer is in an idle state



«Home»-button

- press the button
- ▶ opens the Main Display



«Back»-button

- goes one step back
- Exception:
- decorative stitches
 - alphabets



«Navigation»-buttons left/right/down/up

Chooses in the different menus.

- keep button pressed = scrolls through the menu
- scroll through the stitch patterns by pressing buttons left/right/down/up



«OK»-button

Confirm selection.



«Needle stop»-button

Basic setting is needle stop up (arrow points up).

- press the button
 - ▶ lowers or raises the needle
- keep the button pressed:
 - ▶ lowers the needle
 - ▶ the arrow on the display points down
 - ▶ the sewing computer stops with the needle down
- keep the button pressed again:
 - ▶ raises the needle
 - ▶ the arrow on the display points up
 - ▶ the sewing computer stops with the needle up



«Securing function»-button (3 securing stitches)

- press the button before sewing
 - ▶ single stitches or a stitch combination are secured at the beginning
- press button while sewing a single stitch
 - ▶ the single stitch is secured at the end
 - ▶ the sewing computer stops
- press button while sewing a stitch combination
 - ▶ the stitch combination is secured at the end
 - ▶ the sewing computer stops



Needle stop position up and «Quick Reverse»-button

If the «Quick Reverse»-button is pressed while sewing or after stopping (e.g. zig-zag) with programmed needle stop up, the sewing computer sews one stitch forward before it switches to sewing in reverse.



Needle stop position down and «Quick Reverse»-button

If the «Quick Reverse»-button is pressed after stopping (e.g. zig-zag) with programmed needle stop down, the sewing computer switches to sewing in reverse immediately.



«Mirror image»-button (left/right)

- press the button
- ▶ the active stitch is sewn mirrored



«Pattern begin»-button

- press the button
- ▶ the active stitch pattern or program is set to pattern begin



«Balance»-button

Balances forward and reverse stitches.



«BSR»-button

By pressing the button the BSR mode 1 or 2 is activate when the BSR foot is attached.



«clr»-button

- press the button short
 - ▶ the temporary sewing settings of the active stitch pattern are reset to basic setting
 - ▶ other selected functions are cleared
- keep the button pressed until you hear a beep
 - ▶ the saved sewing settings of the active stitch pattern are reset to basic setting
 - ▶ other selected functions are cleared

Exception:

- needle stop up/down

Overview Display

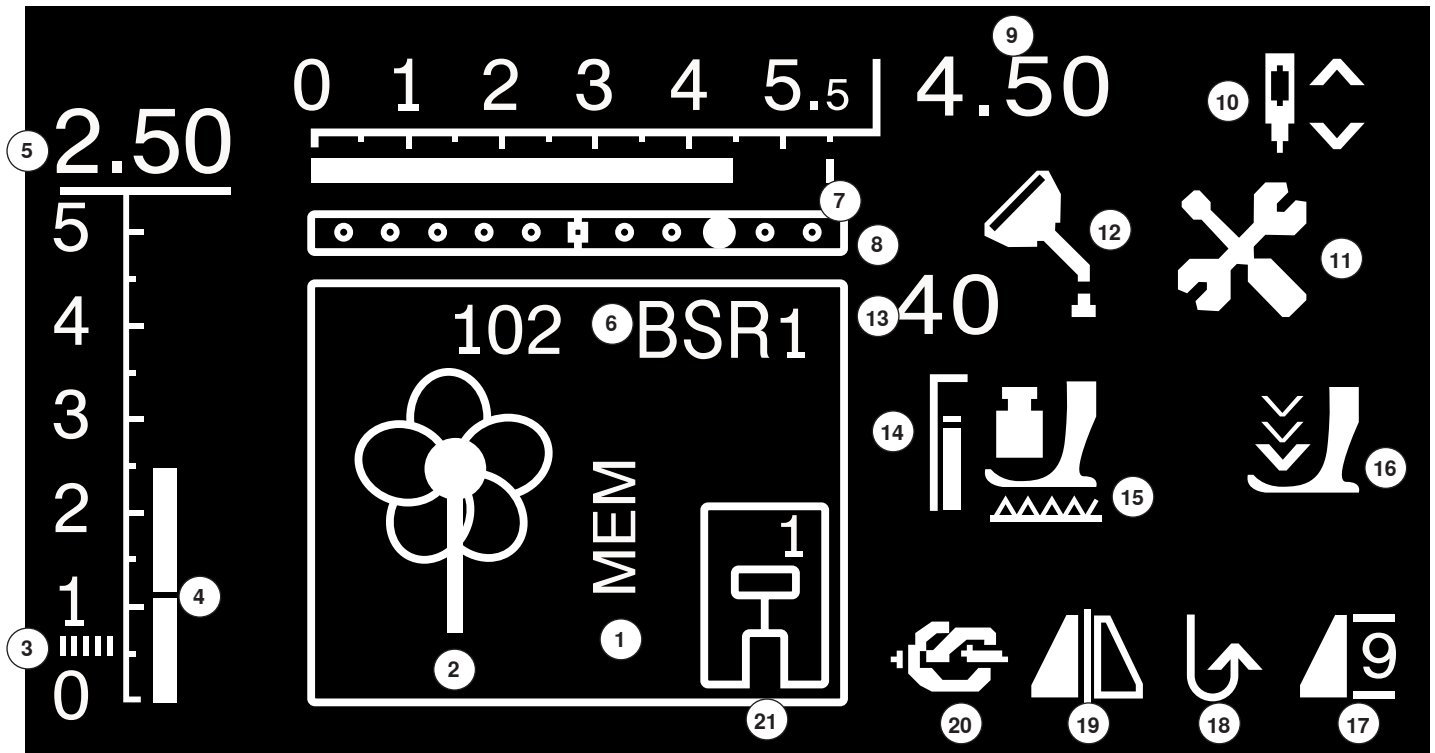

- 1 «MEM»-Display for saved single stitches
- 2 Single stitches: graphical and numerical
- 3 Satin stitch: dense, short zig-zag stitch
- 4 Stitch length: Basic setting
- 5 Stitch length: actual value
- 6 BSR: indicates BSR mode 1 or 2
- 7 Stitch width: Basic setting
- 8 Needle position: 11 possibilities
- 9 Stitch width: actual value
- 10 Needle stop up/down: stops up as standard/in BSR mode 1 down, in BSR-Modus 2 up
- 11 Service icon: visible if the sewing computer needs to be taken to a BERNINA dealer for servicing
- 12 Cleaning icon: visible if the sewing computer needs cleaning or lubrication
- 13 Presser foot pressure: indicates the presser foot pressure while adjusting
- 14 Presser foot pressure: basic setting
- 15 Feed dog icon: indicates whether the feed dog is lowered or raised
- 16 Arrow and presser foot icon: appears if the presser foot is lifted and the sewing computer is started
- 17 Pattern begin/end/repetition
- 18 Continuous reverse sewing
- 19 Mirror: left/right
- 20 Securing function
- 21 Presser foot indicator: shows recommended presser foot for the selected stitch pattern

Main menu



- press «Home»-button

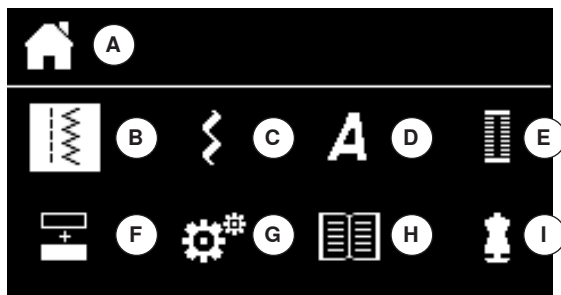

- A Selected menu is displayed
- B Practical stitches
- C Decorative stitches
- D Alphabets
- E Buttonholes
- F Combi mode
- G Setup Program
- H Tutorial
- I Creative consultant

- select the desired menu via the «Navigation»-buttons
- press «OK»-button to confirm

Submenu e.g. practical stitches



- press «Home»-button

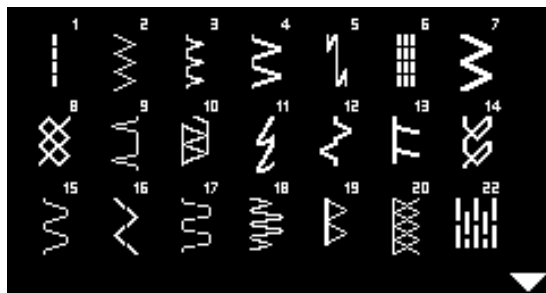

- select practical stitches via «Navigation»-buttons
- press «OK»-button to confirm
- select the desired stitch pattern via the «Navigation»-buttons
- press «OK»-button to confirm

System settings

Setup Program



- press «Home»-button



- select «Setup Program»-icon via «Navigation»-buttons
- press «OK»-button to confirm

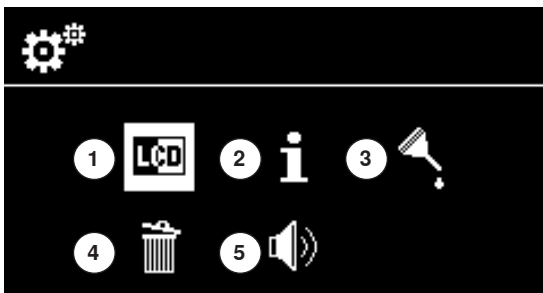

Overview «Setup»-Display

- 1 Display settings
- 2 Information
- 3 Lubricate sewing computer
- 4 Basic Setting
- 5 Beeper for BSR



Brightness and contrast

- select the desired icon via the «Navigation»-buttons down/up
- press «OK»-button
- alter the brightness or the contrast via the «Navigation»-buttons left/right

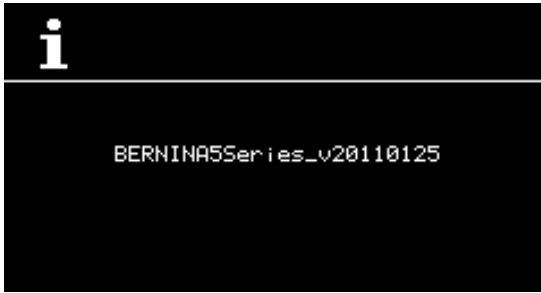

Software version

The current software version of the sewing computer is visible.



Lubricating the sewing computer

- ▶ the icon is displayed when the sewing computer has reached 360,000 stitches
- select the «?»-icon via the «Navigation»-buttons
- press «OK»-button
- ▶ an animation shows the lubrication process
- after lubricating select the «Lubrication»-icon via the «Navigation»-buttons
- press «OK»-button
- the counter under the «Lubrication»-icon is reset to 0



Basic Setting

- press «OK»-button
- ▶ all the sewing settings are reset to the basic settings



Beeper for BSR

- select left icon
- press «OK»-button to confirm
- ▶ Beeper is activated
- select right icon
- press «OK»-button to confirm
- ▶ Beeper is off

Tutorial



- press «Home»-button
- select the «Tutorial»-icon via the «Navigation»-buttons



- 1 Lubricating sewing computer
- press «OK»-button to confirm



An animation shows how the sewing computer has to be cleaned and lubricated.

- press the «Back»-button twice
- ▶ the main display appears

Creative consultant

The creative consultant provides information and help with various sewing techniques. After selecting the fabric and the desired sewing technique suggestions for stitch pattern, presser foot, presser foot pressure and thread tension are displayed.



- press «Home»-button
- select «Creative consultant» via the «Navigation»-buttons
- press «OK»-button to confirm

- select type of fabric via the «Navigation»-buttons
- press «OK»-button to confirm

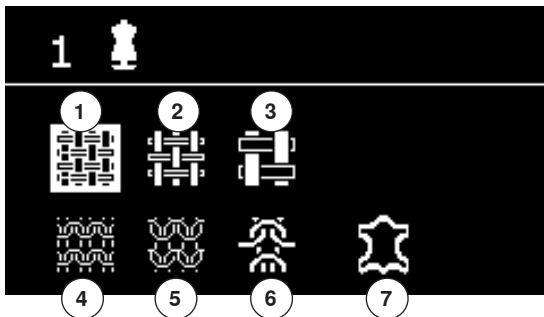

Types of fabric

- 1 Light weight woven fabrics
- 2 Medium weight woven fabrics
- 3 Heavy weight woven fabrics
- 4 Light weight knit
- 5 Medium weight knit
- 6 Heavy weight knit
- 7 Leather/Vinyl

- select a sewing technique via the «Navigation»-buttons
- press «OK»-button to confirm
- ▶ recommendations are displayed

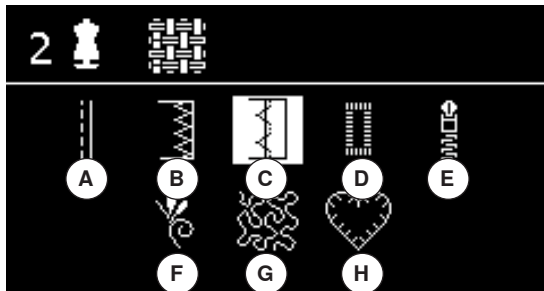

Sewing techniques

- A Seam
- B Overcasting
- C Blind hem
- D Buttonhole
- E Zippers
- F Decorative stitching
- G Free motion stitching
- H Appliqué

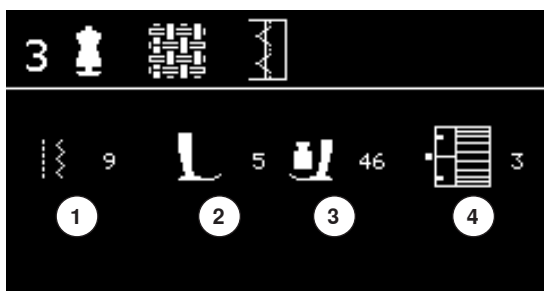

Recommendations

- 1 Number of stitch pattern
- 2 Presser foot
- 3 Presser foot pressure
- 4 Thread tension

Balance

Practical-/decorative stitches

The sewing computer is tested and optimally set before it leaves the BERNINA factory. Different fabrics, threads and stabilizers can affect programmed stitches so that they are not sewn out properly. These effects can be corrected with the electronic Balance so that the stitch formation can be adjusted where necessary to suit the material.



- press «Balance»-button

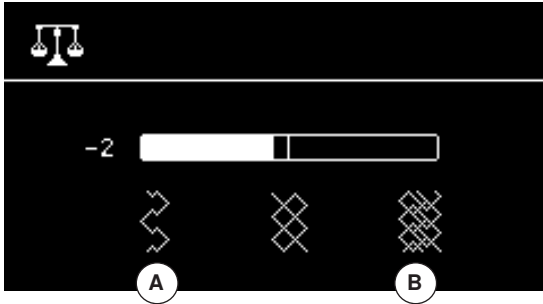

Correcting practical-/decorative stitches

- press left «Navigation»-button
 - ▶ the stitch pattern is stretched **A** (max. 20 steps)
- press right «Navigation»-button
 - ▶ the stitch pattern is compressed **B** (max. 20 steps)
- press «Balance»- or «Back»-button
 - ▶ balance display is closed
 - ▶ alterations are saved
- press the «clr»-button
 - ▶ resets the balance to basic setting

Overview Practical stitches

 <p>1</p>	<p>Straight stitch For non-elastic fabric; all straight stitch work, such as seams, topstitching, sewing zippers</p>	 <p>12</p>	<p>Gathering stitch Most types of fabric. Gathering with shirring elastic. Butted seams = butting two pressed edges and sewing together, decorative stitches</p>
 <p>2</p>	<p>Zig-zag Zig-zag work such as overcasting edges, attaching elastic and lace</p>	 <p>13</p>	<p>Stretch-Overlock Medium weight knits, toweling and firm wovens. Overlock seams, flat joining seams</p>
 <p>3</p>	<p>Vari-overlock For fine jerseys, stretch overlock seams, hems and stretch seams</p>	 <p>14</p>	<p>Jersey stitch For jersey materials; visible seams in lingerie, sweaters, mending jersey</p>
 <p>4</p>	<p>Running stitch Most types of fabric. Mending, patching, reinforcing seams, etc.</p>	 <p>15</p>	<p>Universal stitch Firm fabrics such as felt and leather. Flat joining seams, visible seams, attaching elastic, decorative seams</p>
 <p>5</p>	<p>Securing program For all materials, secures the beginning and end of seams by straight stitching</p>	 <p>16</p>	<p>Sewn out zig-zag Edge finishing and reinforcing, attaching elastic, decorative seam</p>
 <p>6</p>	<p>Triple Straight Stitch For durable seams in firm materials; visible hems and seams</p>	 <p>17</p>	<p>Lycra stitch All two-way stretch fabrics, flat joining seams and hems, reinforced seaming on underwear</p>
 <p>7</p>	<p>Triple zig-zag For durable seams in firm materials; visible hems and seams</p>	 <p>18</p>	<p>Stretch stitch All stretch fabrics; open seam in sportswear</p>
 <p>8</p>	<p>Honeycomb stitch For all types of jersey and smooth materials; visible seams in lingerie, clothing, linen, mending etc.</p>	 <p>19</p>	<p>Reinforced Overlock For medium-weight knitware and toweling; overlock seam, flat joining seam</p>
 <p>9</p>	<p>Blind stitch For most types of material. Blind hems; shell edging effect on soft jerseys and fine material; decorative seams</p>	 <p>20</p>	<p>Knit Overlock For knit material, hand- and machine made items, overlock seam = sewing and finishing in one step</p>
 <p>10</p>	<p>Double Overlock All types of knit; Overlock = sew and neaten in one operation</p>	 <p>22</p>	<p>Simple darning program Automatic darning of fine to medium weight materials</p>
 <p>11</p>	<p>Super stretch All stretch fabrics; open seam in clothing</p>	 <p>30</p>	<p>Basting stitch For basting seams, hems, quilts, etc.</p>

Stitch pattern selection



Via menu selection

- press «Home»-button



- select the desired main category 1-4 via the «Navigation»-buttons
- 1 Practical stitches
- 2 Decorative stitches
- 3 Alphabets
- 4 Buttonholes

- press «OK»-button to confirm

▶ the available stitch patterns are displayed

All of the other stitch patterns can be selected by scrolling via the «Navigation»-buttons.

- select desired stitch number via «Navigation»-buttons
- press «OK»-button to confirm

By stitch number

- select the desired stitch number via the «Direct selection»-buttons

▶ stitch number and basic setting of stitch width and stitch length appear on the display

The «Direct selection»-button 0 selects stitch number 51 (standard buttonhole).

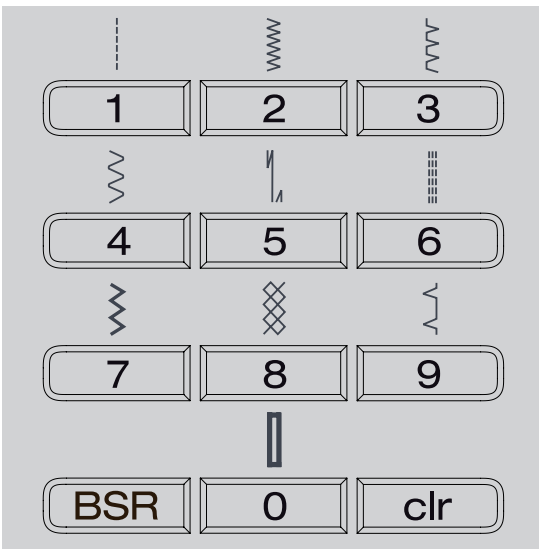

Temporary altered stitch memory

Customizing stitch pattern individually

According to material and purpose a stitch pattern can be altered individually. The alterations described here are applicable for all practical and many decorative stitches.

Any stitch length or width alterations will be saved automatically.

For example:

- sew an altered stitch, e.g. zig-zag
- select and sew another stitch, e.g. straight stitch
- return to zig-zag, your alterations are still active

Return to basic settings

Individual stitch patterns can be reverted to basic settings manually.

- press «clr»-button or
- switch off the sewing computer
- ▶ any alterations of all stitches are deleted

Application:

- for all stitch patterns
- especially useful for alternate applications



The temporary altered stitch memory is unlimited. It can hold alterations to any number of stitches (stitch length, stitch width, needle position, mirror images and balance).

The temporary altered stitch memory fix

The factory basic stitch settings may be altered and saved, even after the sewing computer is turned off. The original settings are always visible.

Altering the basic settings

- select stitch pattern e.g. zig-zag
- alter stitch width and stitch length
- press «OK»-button
- ▶ the alterations are saved

Deleting alterations

- keep the «clr»-button pressed or
- press «Home»-button
- select «Setup Program»-icon via the «Navigation»-buttons
- press «OK»-button to confirm
- select «Delete»-icon via the «Navigation»-buttons
- press «OK»-button to confirm
- «Basic Setting»-icon is selected
- press «OK»-button to confirm
- ▶ the altered stitch pattern are in basic setting

Examples of application

Straight stitch

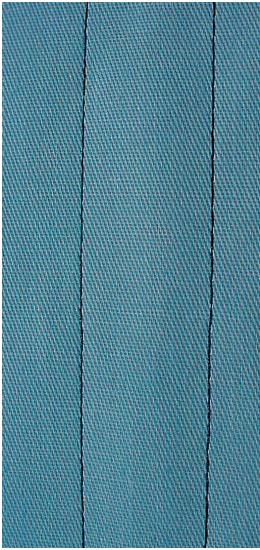

Reverse pattern foot/sole No. 1

Straight stitch No. 1

After turning on the sewing computer the straight stitch will appear.

Application

Suitable for all fabrics.



Adjust the stitch length to suit the fabric

For example, use a longer stitch length (approx. 3-4mm) with denim, a shorter length with fine fabric (approx. 2-2.5mm).

Adjust the stitch length to suit the thread

For example, use a longer stitch length thread when using cordonnet thread for topstitching (approx. 3-5mm).

Activate needle stop down

Prevents the fabric from shifting when you adjust or pivot the sewing project.

Triple straight stitch

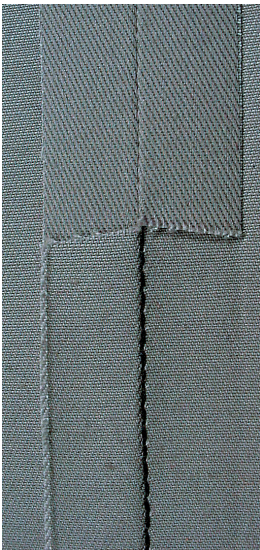

Reverse pattern foot/sole No. 1

Triple straight stitch No. 6

Open seam

Durable seam for firm or dense materials such as denim and corduroy.



For firm or densely woven materials

A Jeans needle and Jeans foot No. 8 will help when sewing denim or canvas.

Decorative topstitching

Lengthen stitch and use the triple straight stitch for decorative topstitching.

Triple zig-zag

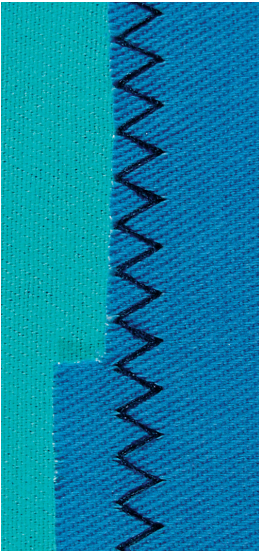

Reverse pattern foot/sole No. 1

Triple zig-zag No. 7

In firm materials, particularly for denim, deckchair covers, awnings.



Seams on often washed items. Finish raw edges first. Use Jeans needle for very firm materials.

Zipper

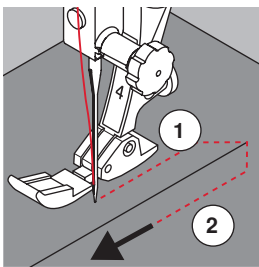
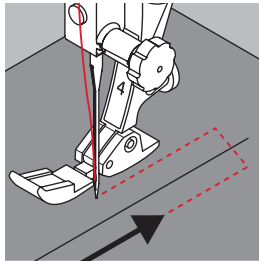
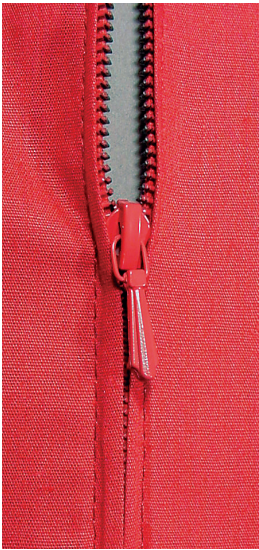

Zipper foot/sole No. 4

Straight stitch No. 1

Preparation

- close seam to the zipper beginning
- sew the securing stitches
- baste seam closed and clean
- finish the seam allowance
- iron the seam
- open the zipper
- baste the zipper
- baste or pin zipper in place so that fabric folded edges meet over the center of the zipper

Sewing in the zipper

- open zipper a little
- move needle position to the right
- start sewing from top left
- position the foot so the needle stitches along the edge of the zipper coils
- stop in front of the pull (needle position down)
- raise the presser foot
- close the zipper again
- lower presser foot
- continue to sew, stop in front of the base of the zipper, needle position down
- raise presser foot
- turn the sewing project
- lower presser foot
- sew across the seam, stop with needle position down
- raise presser foot
- turn sewing project again
- lower presser foot
- sew the second side from bottom to top

Variation: Sew both sides of zipper from bottom to top

Suitable for all fabrics with nap or grain (e.g. velvet).

- prepare zipper as described above
- start sewing in the seam of the zipper end and sew first side from bottom to top
- sew diagonal along the edge of the zipper coils
- first side **1** sew from bottom to top
- move needle position to the left
- second side **2** sew in the same way from bottom to top



Sew around the zipper pull

- sew up to about 5 cm away from the zipper pull
- stop with the needle down, raise the presser foot, open the zipper, lower the presser foot, finish sewing (use Free Hand System)

Seam begin

- hold thread firmly when starting to sew = pull fabric slightly to the back (fewer stitches) or
- sew about 1-2 cm reverse first, and continue to sew as usual

Zipper or fabric is thick or densely woven

For even stitch formation use a 90-100 needle.

Manual darning

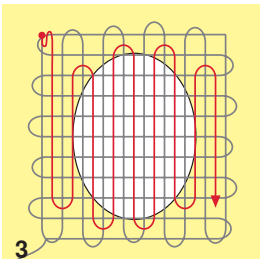
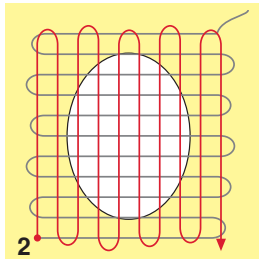
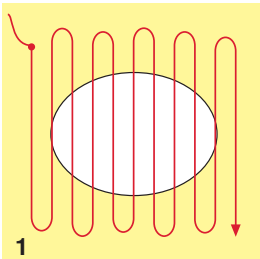
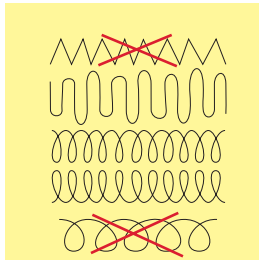

Darning foot No. 9 ^{*/**}

Straight stitch No. 1

Holes or worn areas

«Replacing» threads along the lengthside and crosswise in every material.

Preparation

- lower the feed dog
- attach slide-on table
- hoop the sewing project plus stabilizer into the darning hoop (optional accessory)
- ▶ the darning area stays evenly taut and cannot be distorted

Sewing

- work from the left to the right, guide the fabric evenly without using pressure
- move in curves when changing direction on top and on bottom. Avoid points as this can cause holes and thread breakage
- work in different length so the thread is better spread over the fabric

1 Sew the first rows to cover the hole

- first rows just beyond the worn area and not too close together
- work the rows in irregular lengths
- turn fabric by a quarter turn -90°

2 Sew over the first rows

- first rows not too close
- turn fabric by half turn -180°

3 Finish darning the hole

- sew another loose row



Poor stitch formation

- if the thread is lying on top, slow down the fabric movement
- if there are knots on the wrong side of the fabric, move the fabric more quickly

Thread breaks

Guide the fabric with a more consistent speed.

Automatic darning

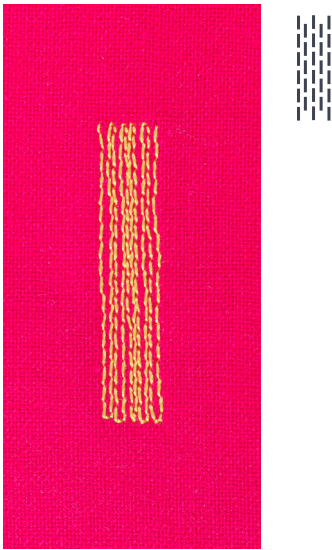

Reverse pattern foot/sole No. 1
Automatic Buttonhole foot with slide No. 3A

Darning program No. 22

Quick darning of holes or worn areas

Replaces threads along the lengthwise grain in all materials.

Preparation

- hoop light-weight materials in the darning hoop (optional accessory)
- ▶ the darning area stays evenly taut and cannot be distorted

Darning with reverse pattern foot/sole No. 1

- insert the needle in the top left of the worn area
- sew first row
- stop sewing computer
- press «Quick reverse»-button
- ▶ the length is programmed
- finish sewing the darning program
- ▶ the sewing computer stops automatically
- press the «clr»-button
- ▶ the program is cleared

Darning with the automatic buttonhole foot with slide No. 3A

- for darning worn and damaged areas
- Darning length max. 3cm
- same procedure as with foot No. 1



Reinforcement

Use fine material or (adhesive) interlining as a backing.

Darning area becomes distorted

Correct with the Balance function (see Balance-Function page 36).

Zig-zag

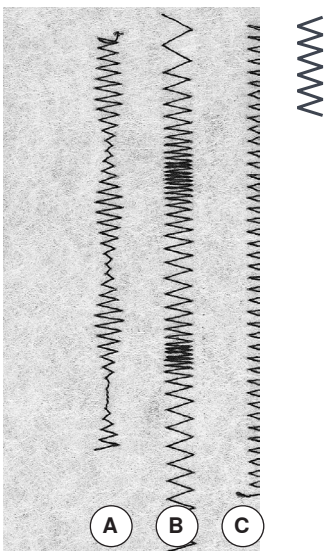

- A** Zig-zag with altered stitch width
- B** Zig-zag with altered stitch length
- C** Finishing edges with zig-zag

Reverse pattern foot/sole No. 1

Zig-zag No. 2

- for all fabrics
- for finishing raw edges
- elastic seams
- decorate sewing

Finishing edges

- guide edge of fabric into the center of the presser foot
- do not select too wide a stitch
- do not select too long a stitch
- needle goes into fabric on one side and over the edge into the air on the other side
- the edge of the fabric should lie flat and not roll
- use a fine darning thread for lightweight fabric

Satin stitch

- dense, short zig-zag (stitch length 0.5-0.7mm)
- use satin stitch for appliqué, embroidery, etc.

Double overlock



Reverse pattern foot/sole No. 1

Double overlock No. 10

Closed seam

Double overlock seam in loose knits and cross seams in knits and jerseys.



Knits and jersey

- use a new Jersey needle to prevent damaging the loops
- if necessary loosen presser foot pressure

Sewing stretch materials

If necessary use a stretch needle (130/705 H-S).

Top stitching edges

Blindstitch foot/sole No. 5
Reverse pattern foot/sole No. 1
Edge stitch foot No. 10 */**

Straight stitch No. 1

Narrow edgestitching

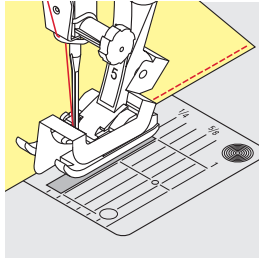

Outer edges

- place edge of fold left against the guide on the blindstitch foot/sole
- select needle position at the desired distance left from the folded edge

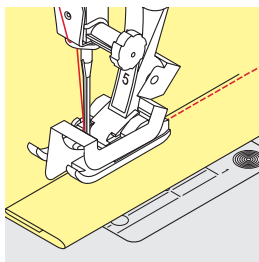

Hem edges

- place edge of fold (inside upper edge of hem) right against the guide on the Blindstitch foot/sole
- select needle position to the right to sew along the upper edge



Blindstitch foot/sole No. 5
 Needle position left or far right.

Reverse pattern foot/sole No. 1 and Edge stitch foot No. 10
(optimal accessory)
 Any needle position possible.

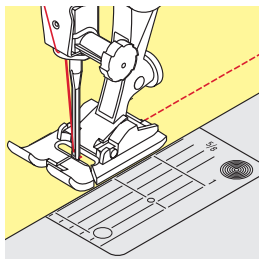

Wide edgestitching

Material guidance

Presser foot as guide:

- guide the folded edge along the edge of the presser foot

Stitch plate as guide:

- guide the folded edge along the marks on the stitch plate (1 to 2.5cm)

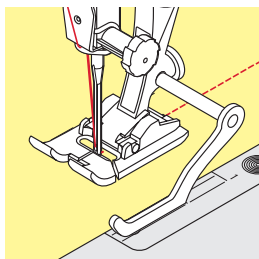

Seam guide as guide:

- loosen the screw on the back of the presser foot
- insert the seam guide into the hole of the presser foot
- adjust the wide as desired
- tighten the screw
- guide the folded edge along the seam guide

Presser foot shaft/sole

- insert the seam guide into the hole of the presser foot shank
- adjust wide as desired
- guide the folded edge along the seam guide

To sew parallel wide lines, guide the seam guide along a previously sewn line of stitches.

Blind hem

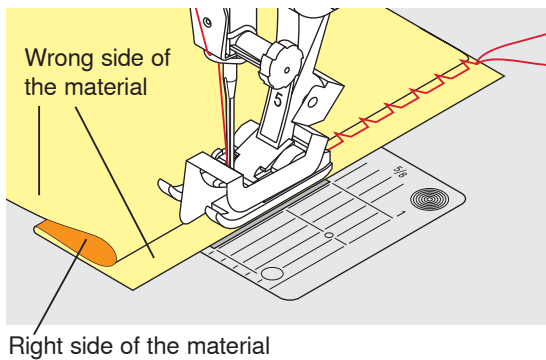
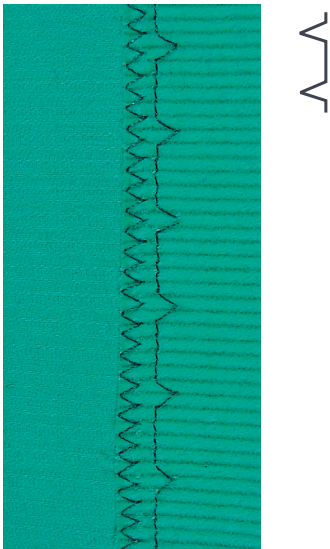

Blindstitch foot/sole No. 5

Blindstitch No. 9

For invisible hems in medium to heavy cotton, wool and blended materials.

Preparation

- finish raw edges
- fold and baste or pin the hem

- fold the fabric back over the right side of the fabric to expose the finished lower edge
- place under presser foot and
- move the folded edge against the metal guide on the presser foot

Sewing

- the metal guide on the sole of the blindstitch sole can be adjusted sideways by turning the screw on the right
- the needle should just pierce the edge of the fold (as when hand blind-stitching)
- after sewing about 10cm, check both sides of fabric and adjust width again if necessary



Fine stitch width adjustment

Guide the folded edge evenly along the metal guide on the foot = even depth.
Guide the raw edge along the guide on the foot to keep the stitch depth even.

Hem visible

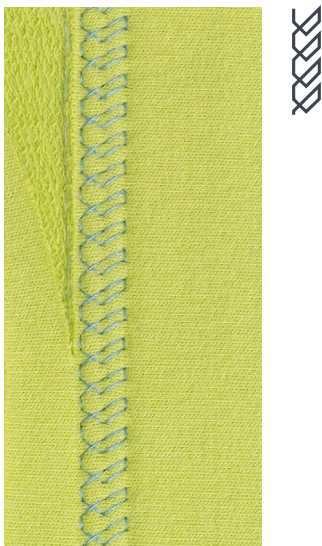

Reverse pattern foot/sole No. 1

Jersey stitch No. 14

For visible, elastic hems in jersey, cotton, synthetic and mixed fibers.

Preparation

- iron the hem, baste if necessary
- reduce the presser foot pressure if necessary

Sewing

- sew the hem at preferred depth on the right side
- trim excess fabric from the wrong side

Securing program



Reverse pattern foot/sole No. 1

Securing program No. 5

- for all fabrics
- secures beginning and end of seam

Sewing long seams with straight stitch

Even securing by defined stitch count.

Sew begin

- press the foot control
- ▶ the sewing computer secures automatically when beginning to sew (5 stitches forward, 5 stitches reverse)
- sew seam with straight stitches in desired length



Ending the seam

- press «Quick reverse»-button
- ▶ the sewing computer secures seam automatically (5 stitches reverse, 5 stitches forward)
- ▶ the sewing computer stops automatically at the end of the securing program

Basting stitch

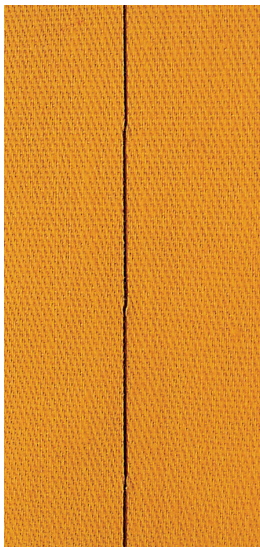

Darning foot No. 9 */**

Basting stitch No. 30

- for work which requires a very long stitch
- bastes seams, hems, quilts etc.
- temporary joining
- easy to remove

Preparation

- lower the feed dog
- pin work at a right angle to basting direction
- ▶ to prevent the layers from slipping

Basting

- place fabric under the presser foot
- hold the threads while sewing the first stitch
- pull work from behind to the required length of the stitch
- sew one stitch
- repeat the procedure



Securing/fixing the thread

Lower feed dog, sew at the beginning and at the end 3-4 basting stitches in the same place.

Thread

Use a fine darning thread for basting as it is easier to remove.

Flat joining seam

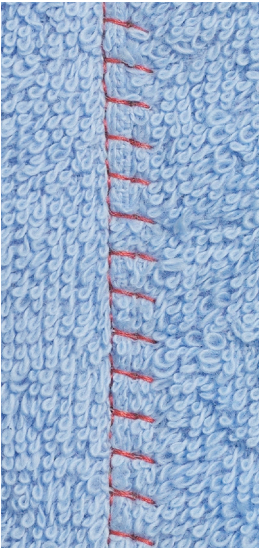

TTTTT

Reverse pattern foot/sole No. 1

Stretch-overlock No. 13

Ideal for fluffy or thick materials such as terry cloth, felt and leather etc.

Sewing

- overlap fabric edges
- sew stretch overlock along the fabric edge
- the stitch should sew over the edge of the top layer on the right side
- ▶ very flat durable seam

Height compensation of uneven layers

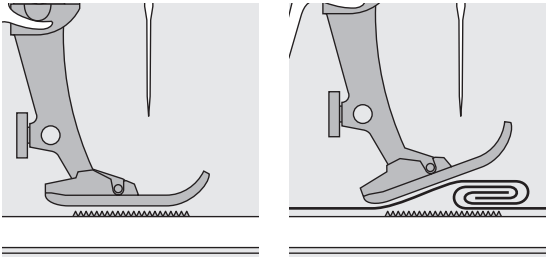

The feed dog works accurately when the foot is level.

If the foot is at an angle, e.g. when sewing over thick to thin or vice-versa, the feed dog cannot grip and feed the fabric. The fabric might jam.

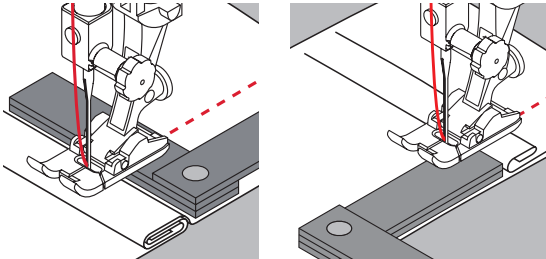

To solve this problem, place one, two or three compensating plates as required behind the needle under the presser foot to level it.

To correct the height in front of the foot, place one or more plates under the foot close to the needle. Sew until the foot is level again and remove the plates.



Needle stop down.

Sewing corners

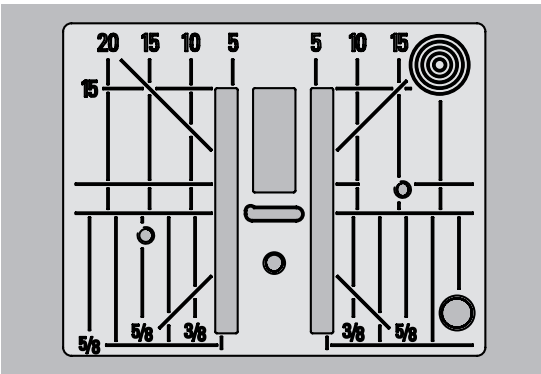

Due to the width of the stitch plate hole the outer feed dog rows are relatively far apart.

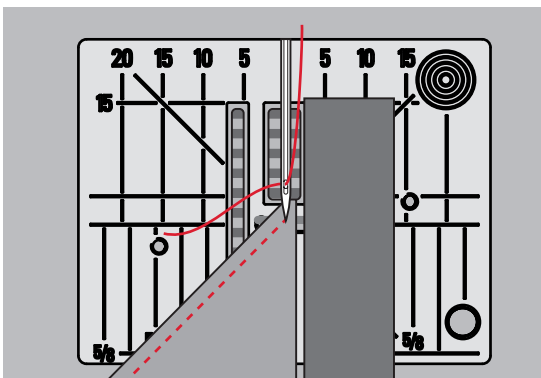

When sewing corners only a small section of the fabric is actually on the feed dog. Therefore it cannot grip the fabric well.











Place one or more plates of the height compensation tool parallel to the presser foot close to the edge of the fabric.

▶ the fabric is fed evenly



Needle stop down.

Overview Buttonhole

 51	<p>Standard buttonhole For light to mediumweight fabrics; blouses, shirts, trousers, bedlinens, etc.</p>	 59	<p>Straight-stitch buttonhole Program for staystitching buttonholes, for pocket openings, reinforcing buttonholes; especially for buttonholes in leather and imitation leather</p>
 52	<p>Narrow buttonhole For light- to medium weight fabrics; blouses, dresses, children's and baby clothes, crafts</p>	 60	<p>Button sew-on program For buttons with 2 and 4 holes</p>
 53	<p>Stretch buttonhole All stretch fabrics made from cotton, wool, silk and synthetic fibers</p>	 61	<p>Eyelet with small zig-zag * Openings for cords and narrow ribbons, decorative work</p>
 54	<p>Round buttonhole For medium- to heavy weight materials: dresses, jackets, coats, rainwear</p>	 62	<p>Straight-stitch eyelet Openings for cords and narrow ribbons, decorative work</p>
 56	<p>Keyhole buttonhole For heavy weight, non-stretch materials: jackets, coats, leisure wear</p>	 63	<p>Heirloom buttonhole For light- to medium weight woven fabrics: blouses, dresses, leisure wear, bed linen</p>

Buttonhole - important information

Buttonholes are not only practical closures, they can also be used to decorative effect.



- press «Home»-button
- select «Buttonhole» via the «Navigation»-buttons
- press «OK»-button to confirm or
- select the desired buttonhole with the «Direct selection»-buttons

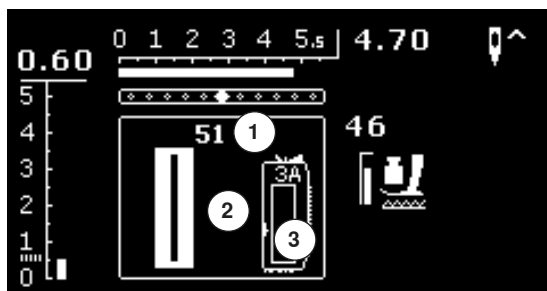

- Display shows:
- 1 Buttonhole number
 - 2 Buttonhole icon
 - 3 Presser foot indicator

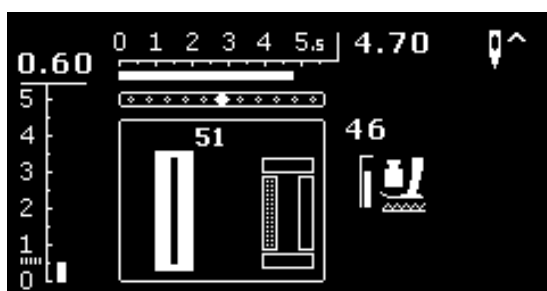

When beginning to sew the actual sequence of the buttonhole is displayed instead of the presser foot indicator.

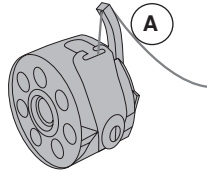

Thread tension for sewing buttonholes

- thread the bobbin thread through the finger **A** of the bobbin case
- ▶ the bobbin thread tension is a little tighter
- ▶ this gives the beads on the right side of the fabric a slightly rounded appearance



An additional cord reinforces buttonholes and enhances their appearance (see page 54).

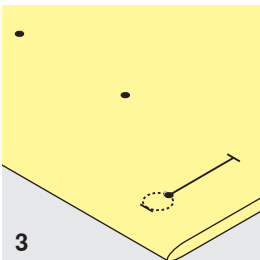
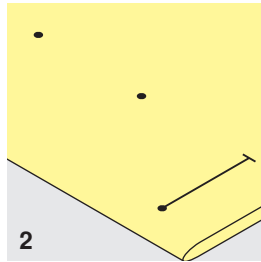
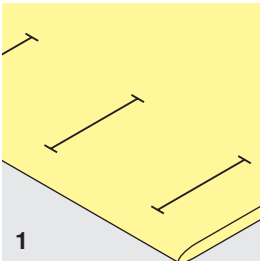

1 Marking the length of manual buttonholes

- mark the buttonhole length in the desired position
- use buttonhole foot/sole No. 3 **/**

2 Marking the length of automatic buttonholes

- mark the length of just one buttonhole
- ▶ after sewing the first buttonhole, the length for all subsequent buttonholes is automatically programmed
- mark only the beginning of all subsequent buttonholes
- use automatic buttonhole foot with slide No. 3A

3 Marking the length of keyhole buttonholes

- mark the bead length only
- ▶ the correct length eye will be added when the buttonhole is sewn
- ▶ after sewing the first buttonhole, the length for all subsequent buttonholes is automatically programmed
- mark only the beginning of all subsequent buttonholes
- use automatic buttonhole foot with slide No. 3A

Test-sewing

- always sew a test sample on the original fabric and with stabilizer you intend to use
- select the buttonhole type you intend to use
- sew the buttonhole in the same direction on the fabric (horizontal or vertical, with or against the grain)
- cut the buttonhole open
- push the button through
- adjust the buttonhole length if necessary

To adjust the bead width

- alter the stitch width

Altering stitch length

Stitch length adjustments affect both buttonhole beads.

- ▶ spacing between the stitches

After stitch length alteration.

- re-program the buttonhole



If a buttonhole is to be sewn at right angles to the seam, we recommend the use of the height compensation plates (optional accessory). Place the plates from the back between fabric and bottom of slide foot up to the thick part of the fabric and push to front.

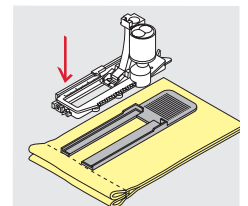

When sewing a buttonhole in difficult materials, we recommend to use the Compensation plate for buttonholes (optional accessory). It can be used along with buttonhole foot with slide No. 3A.

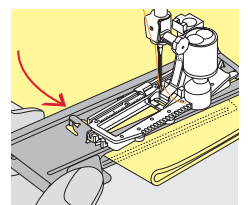

Stabilizer and interfacing

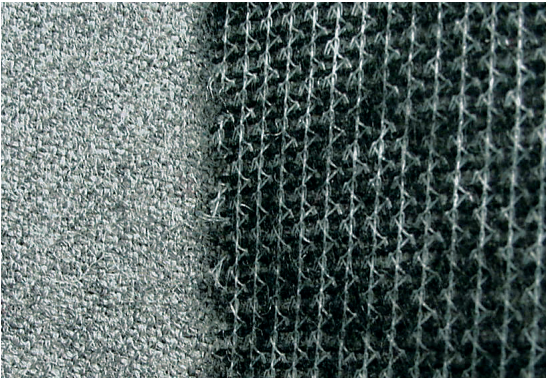

- interfacing provides durability and stability to the buttonhole
- choose the interfacing according to the material being used

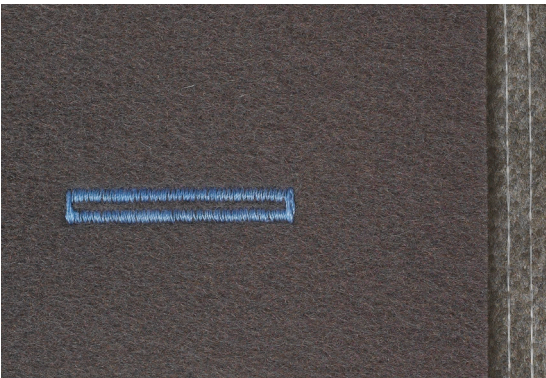

- when using thick or fluffy materials an embroidery stabilizer can be used
- ▶ therefore the fabric feeds better

Cording

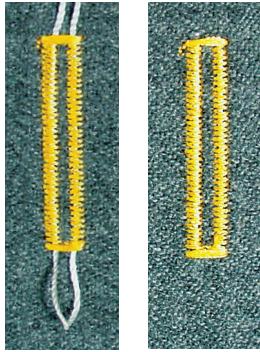
**General facts**

- use cording to reinforce buttonholes and enhance their appearance
- the loop of the cord should be at the end of the buttonhole that is most subject to wear = where button is sewn on
- position the work accordingly

Ideal cords

- Perle cotton No. 8
- strong hand-sewing thread
- fine crochet yarn

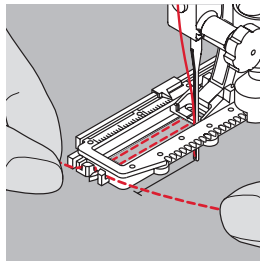
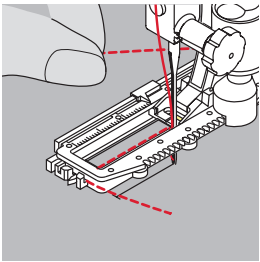
**Cord with the automatic buttonhole foot with slide No. 3A**

- raise the buttonhole foot No. 3A
- insert the needle at the beginning of the buttonhole
- guide the cord on the right side under the buttonhole foot No. 3A
- hook the cord over the pin at the back of the buttonhole foot No. 3A
- pull the cord on the left side under the buttonhole foot No. 3A to the front
- pull the cord ends into the slits
- lower buttonhole foot No. 3A

Sewing

- sew the buttonhole in the usual manner
- do **not** hold the cord
- ▶ the buttonhole will sew over the cord, covering it

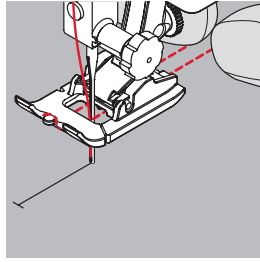
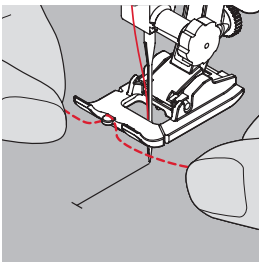
**Cord with buttonhole foot/sole No. 3 **/**

- raise buttonhole foot
- insert the needle at the beginning of the buttonhole
- hook cord over the pin in the middle of the buttonhole foot (at the front)
- pull both cord ends under the buttonhole foot sole to the back and
- place both ends of the cord in the grooves on the sole
- lower the buttonhole foot

Sewing

- sew the buttonhole in the usual manner
- do **not** hold the cord
- ▶ the buttonhole will sew over the cord, covering it

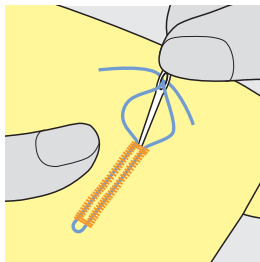
**Securing the cord**

- pull the cord through the buttonhole until the loop disappears into the end of it
- pull the ends of the cord through to wrong side of the fabric, using a hand stitching-needle
- knot or secure with stitches

**Before cutting the buttonhole open**

Place a pin in each end of the buttonhole to prevent accidental cutting into ends of buttonhole.

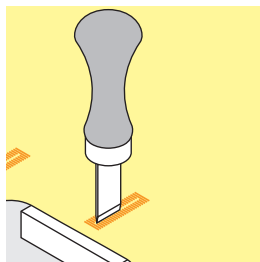
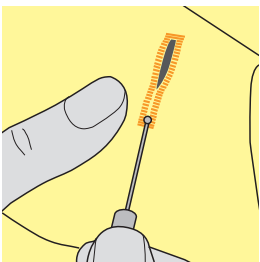
**Cutting buttonholes open with the seam ripper**

- cut the buttonhole from the ends to the middle

Cutting open buttonholes with the Buttonhole Cutter (optional accessory)

- place the fabric on the wood
- place the cutter in the centre of the buttonhole
- press down on the cutter with your hand

Balance

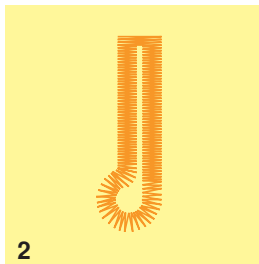
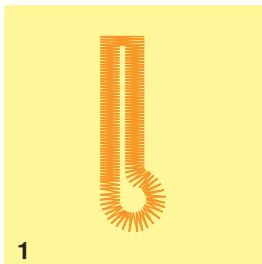

Balance for automatic and manual buttonholes

Any balance alterations to the manual and auto-length buttonholes affect both beads identically because they are sewn in the same direction.

The keyhole or eye is balanced as follows:

- sew straight stitches forward until
- ▶ the sewing computer switches to the eye
- stop the sewing computer
- press the «Balance»-button
- ▶ the balance display appears



1 the keyhole is distorted to the right

- press the left «Navigation»-button
- ▶ the keyhole is corrected to the left

Test-sewing!

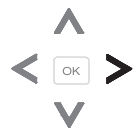

2 the keyhole is distorted to the left

- press the right «Navigation»-button
- ▶ the keyhole is corrected to the right

Test-sewing!



When all buttonholes have been sewn, return balance to the normal setting! (see page 36)

Standard and stretch buttonhole with auto-length, automatically

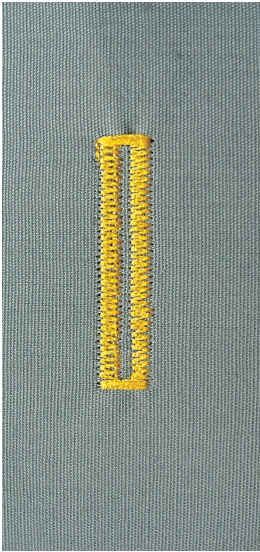

Automatic buttonhole foot with slide No. 3A

Automatic standard and stretch buttonhole No. 51, 52, 53

The lens on automatic buttonhole foot No. 3A automatically registers the length of the buttonhole for exact duplication.

Preparation

- select the desired buttonhole
- Display shows:
- ▶ the number of the selected buttonhole
 - ▶ Automatic buttonhole foot No. 3A



The slide foot must lie perfectly flat on the fabric! If the slide foot rests on a seam allowance, the length cannot be measured accurately.

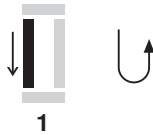

1

Programming the buttonhole

- 1 ■ sew first bead forward
- stop sewing computer
- press «Quick reverse»-button
- ▶ «auto» is shown on the display
- ▶ the buttonhole length is programmed

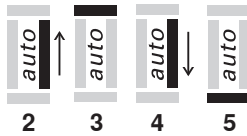

2

3

4

5

The sewing computer sews automatically:

- 2 the straight stitches in reverse
- 3 the first bartack
- 4 the second bead forwards
- 5 the second bartack and securing stitches
- ▶ the sewing computer stops and returns automatically to buttonhole begin

Auto-buttonhole

- all subsequent buttonholes will be sewn to exactly the same length (no need to press the «Quick reverse»-button)
- the programmed buttonhole can be saved in the long-term memory (see page 58)
- press the «clr»-button
- ▶ the programmed settings are cleared



Exact duplication

The auto function ensures that each buttonhole will be exactly the same length as the previous one.

Sewing speed

- sew at moderate speed for best results
- sew all buttonholes at the same speed for a consistent bead density

Automatic round and keyhole buttonhole

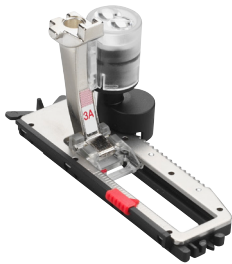

Automatic buttonhole foot with slide No. 3A

Automatic round and keyhole buttonhole No. 54, 56

Preparation

- select the desired buttonhole
- Display shows:
- ▶ the number of the selected buttonhole
 - ▶ Automatic buttonhole foot No. 3A



The slide foot must lie perfectly flat on the fabric! If the slide foot rests on a seam allowance, the length cannot be measured accurately.



1

Programming the buttonhole

- 1 ■ sew straight stitches forward
- stop sewing computer
- press «Quick reverse»-button
- ▶ «auto» is shown on the display
- ▶ the buttonhole length is programmed

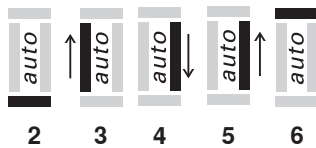

The sewing computer sews the following automatically:

- 2 the eye
- 3 the first bead in reverse
- 4 the straight stitches forward
- 5 the second bead in reverse
- 6 the bartack and securing stitches
- ▶ the sewing computer stops and returns automatically to buttonhole begin

Auto-buttonhole

- all subsequent buttonholes will be sewn to exactly the same length (no need to press the «Quick reverse»-button)
- the programmed buttonhole can be saved in the long-term memory (see page 58)
- press the «Clr»-button
- ▶ the programmed settings are cleared



Exact duplication

The auto function ensures that each buttonhole will be exactly the same length as the previous one.

Double sewn keyhole buttonholes

- keyhole buttonholes can be sewn twice on thick fabrics - use a longer stitch length for the first run
- after sewing the first buttonhole, do not move the work
- reduce the stitch length manually and sew the buttonhole again

Heirloom buttonhole

Automatic buttonhole foot No. 3A

Heirloom Buttonhole No. 63

Preparation

- select buttonhole

Display shows:

- ▶ the number of the selected buttonhole
- ▶ Automatic buttonhole foot No. 3A

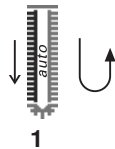

1

Programming the buttonhole

- 1 ■ sew the first bead forwards
- stop the sewing computer
- press «Quick reverse»-button
- ▶ «auto» is shown on the display
- ▶ buttonhole length is programmed

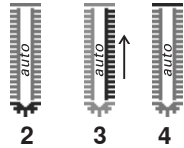

2

3

4

The sewing computer sews the following automatically:

- 2 the round part
- 3 the second bead in reverse
- 4 the bartack and the securing stitches
- ▶ the sewing computer stops and returns automatically to buttonhole begin

Auto-buttonhole

- ▶ all subsequent buttonholes will be sewn to exactly the same length (no need to press the «Quick reverse»-button)
- the programmed buttonholes can be saved in the long-term memory
- press the «clr»-button
- ▶ the programmed settings are cleared

Buttonhole in long term memory

Buttonhole in long term memory

- program buttonhole
- press «OK»-button
- ▶ the buttonhole is now saved in long term memory
- ▶ «mem» is displayed

Selection of a saved buttonhole

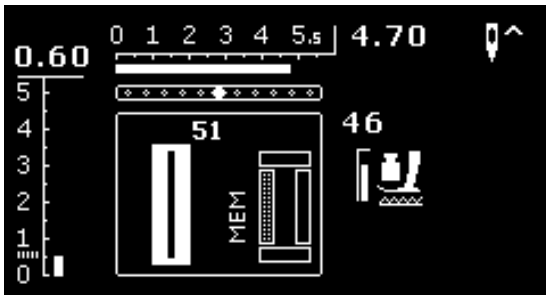

Programmed saved buttonholes can be opened for re-use even after the sewing computer has been disconnected.

- select the desired buttonhole type
- sew programmed buttonhole
- ▶ only one length per buttonhole can be saved
- when a new length is confirmed by «OK», the previously saved length will be overwritten

Manual buttonhole (all types)

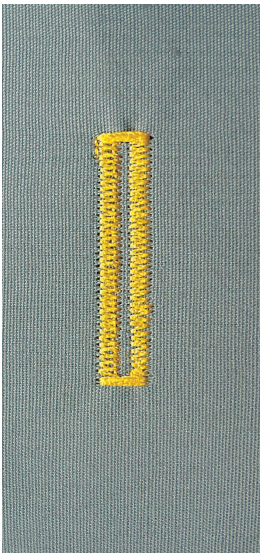

Sewing buttonholes manually is ideal if you only need to sew one; also for repairing existing buttonholes. The number of steps depends on the type of the selected buttonhole. Manual buttonholes cannot be saved.

Buttonhole foot/sole No. 3 */**

Preparation

- select the desired buttonhole
- The display shows:
- ▶ the number of the selected buttonhole
 - ▶ Automatic buttonhole foot No. 3A

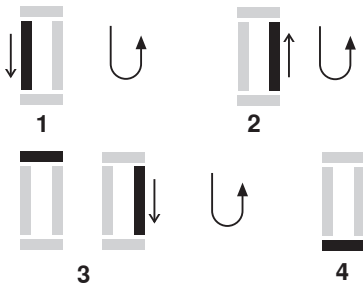

Sewing a manual standard buttonhole

- 1 ■ sew the bead up to the end of the length marking
 - stop sewing computer
 - press «Quick reverse»-button
- 2 ■ sew straight stitch in reverse
 - stop sewing computer at height of the first stitch (buttonhole begin)
 - press «Quick reverse»-button
- 3 ■ sew upper bartack and second bead
 - stop sewing computer
 - press «Quick reverse»-button
- 4 ■ sew lower bartack and securing stitches

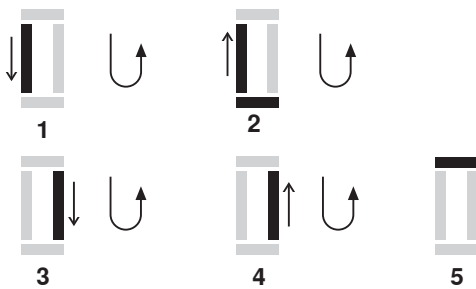

Sewing manual keyhole or round buttonhole

- 1 ■ sew straight stitches forward up to the end of the length marking
 - stop sewing computer
 - press «Quick reverse»-button
- 2 ■ sew keyhole and first bead in reverse
 - stop sewing computer at the height of the first stitch (buttonhole begin)
 - press «Quick reverse»-button
- 3 ■ sew straight stitches forwards
 - stop sewing computer at the keyhole
 - press «Quick reverse»-button
- 4 ■ sew second bead in reverse
 - stop sewing computer at the height of the first stitch (buttonhole begin)
 - press «Quick reverse»-button
- 5 ■ sew bartack and securing stitches



Sew both beads at the same speed.

Button sew-on program

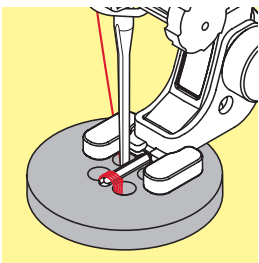
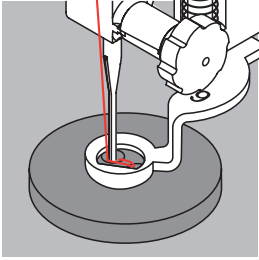
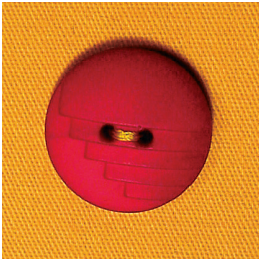

Darning foot No. 9 */**

Button sew-on foot No. 18 */**

Button sew-on program No. 60

For buttons with 2 and 4 holes.

Sewing on buttons

Buttons sewn on for decorative purposes only are stitched without a thread shank.

The length of the shank (= thread between button and fabric) can be made shorter or longer as required with foot No. 18.

Sewing on buttons with darning foot No. 9 */**

- select button sew-on program
- check distances between holes with the handwheel
- adjust stitch width if necessary
- hold the threads when starting to sew
- sew the first securing stitches into the left hole
- sewing the button sew-on program
- ▶ sewing computer stops automatically when program is completed and is ready for the next button

Beginning and ending threads

The threads are secured and can be trimmed.

For secure results

- pull on both bobbin threads until the ends of the upper threads are visible on the wrong side
- pull the threads out and knot the ends additionally
- trim the threads

Sewing on buttons with foot No. 18 */**

- set the shank length with the screw on the foot
- select button sewing-on program and continue as with foot No. 9 */**



Sewing 4-hole button

- sew the front holes first
- carefully move the button forward
- sew the back holes with the same program



For a increased stability the button sew-on program can be sewn twice.

Eyelet program



Reverse pattern foot/sole No. 1

Eyelet with small zig-zag No. 61 *
Straight-stitch eyelet No. 62

Sewing eyelets

- select eyelet
- position fabric under the presser foot and sew eyelet program
- ▶ sewing computer stops automatically and is at the beginning of the eyelet program again

Punching eyelets

- use an awl, punch pliers or a hole punch to open the eyelet



Adjust the roundness of the eyelet if necessary with balance.
For increased stability sew the eyelet twice.

Selecting a decorative stitch



- press «Home»-button



- select «Decorative Stitches»-icon via the «Navigation»-buttons
- press «OK»-button to confirm

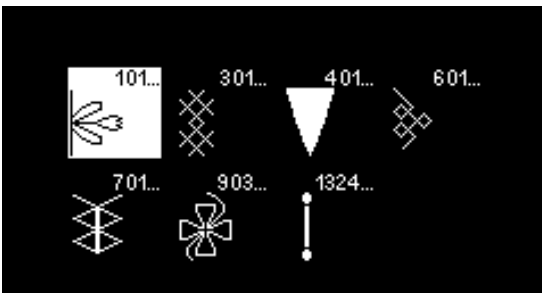

- ▶ display shows an overview of the categories
- select the desired category via the «Navigation»-buttons
- press «OK»-button to confirm
- ▶ the desired category is activated
- select the desired stitch pattern
- press «OK»-button to confirm

Application

Depending on the type of material, simple or more complex decorative stitches should be selected to best suit the material.

- decorative stitches which are programmed with simple straight stitches, are particularly appropriate for light weight materials, e.g. decorative stitch No. 101
- decorative stitches which are programmed with triple straight stitches or with a few satin stitches are particularly appropriate for medium weight materials, e.g. decorative stitch No. 615
- decorative stitches which are programmed with satin stitches are particularly appropriate for medium weight materials, e.g. decorative stitch No. 401



Categories

- Cat. 100 = Florals
- Cat. 300 = Cross stitches
- Cat. 400 = Satin stitches
- Cat. 600 = Ornamental stitches
- Cat. 700 = Heirloom stitches
- Cat. 900 = Novelty
- Cat. 1300 = Quilt stitches



Perfect stitch formation

- use the same thread color for upper and lower thread
- reinforce the fabric on the wrong side using stabilizer
- use an additional, water-soluble stabilizer on the right side of pile or longfiber materials (e.g. wool, velvet etc.) which can be easily removed after sewing

Overview Quilt stitches

Various stitch patterns are available which are used especially in quilting, for patchwork or for appliqué.

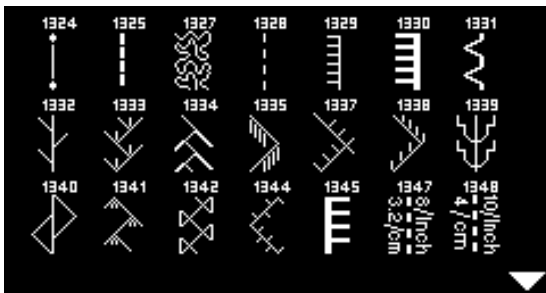

- press «Home»-button
- select «Decorative Stitches»-icon via the «Navigation»-buttons
- press the «OK»-button to confirm
- ▶ display shows an overview of the categories
- select category quilt stitches
- press the «OK»-button to confirm
- select the desired stitch pattern



Quilters' securing program



Feather stitch



Quilting straight stitch *



Feather stitch variations
1333-1338 * (partly)



Stippling stitch

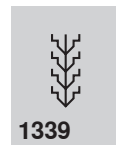

Decorative quilt stitch variations
1339-1342, 1344-1345 * (partly)



Handlook quilt stitch



Handlook quilt stitch variations *
1347-1348



Blanket stitch



Blanket stitch (dual)

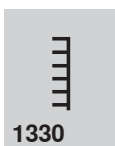

Double blanket stitch



Double blanket stitch (dual) *



Blind stitch (narrow)



Satin stitch

Handlook quilt stitch

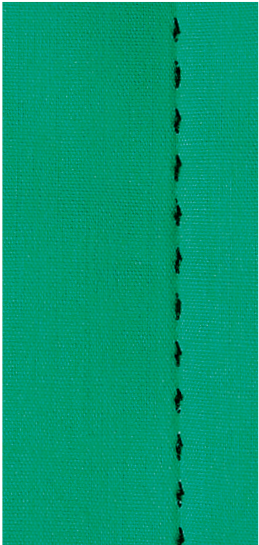

10/inch
4/cm
8/inch
3.2/cm

Reverse pattern foot/sole No. 1

Handlook quilt stitch No. 1328, 1347 *, 1348 *

Suitable for all fabrics and work which should look «hand sewn».

Thread

- Upper thread = Monofilament
- Lower thread = 30/2 cotton thread

Test-sewing

- ▶ the lower thread is pulled up by strong upper thread tension
- **one** stitch is visible (bobbin thread)
- **one** stitch invisible (monofilament) = hand-look effect

Upper thread tension

Depending on the fabric increase the tension (6-9).

Balance

Adjust stitch with the balance if necessary.



Perfect corners

- press «Needle stop»-button, needle down, press «Pattern end/pattern repeat»-button, turn fabric
- when pivoting make sure that the fabric does not become distorted

Monofilament breaks

- sew more slowly
- reduce upper thread tension slightly

Free-motion quilting

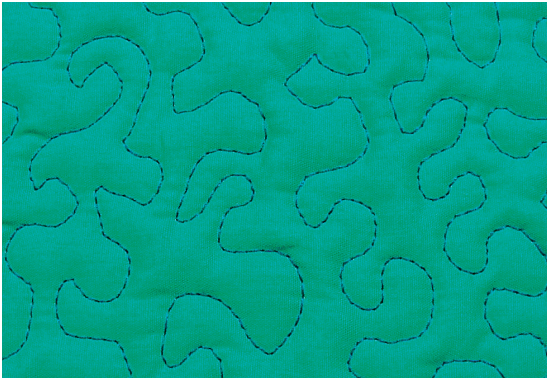

Darning foot No. 9 */**

Straight stitch No. 1

Free-motion quilting

For all types of free motion quilting work.

Preparation

- pin top layer, batting and backing together, or baste if necessary
- attach slide-on table
- use the Free Hand System
- lower the feed dog

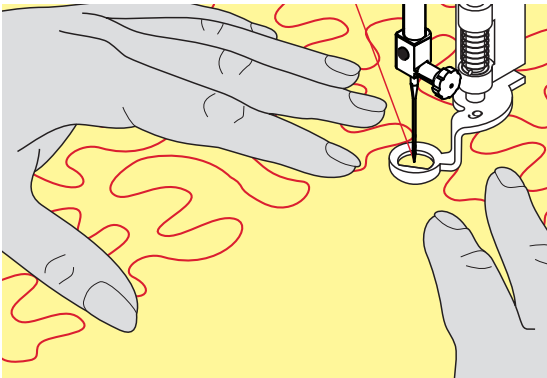

Holding the work

- hold the work with both hands like an embroidery frame



Quilt gloves with rubber fingertips will help when guiding the work.

Quilting a design

- quilt from the center outwards
- guide the work using smooth, round movements to form the design of your choice

Stipple quilting

- this technique covers the entire surface of the fabric with quilt stitches
- the lines of stitching are rounded and never cross one another



Free-motion quilting and darning

The two techniques are based on the same Free Motion principles.

Poor stitch formation

- if thread is lying on top of the fabric, slow down the movement of the material
- if there are knots on the wrong side of the fabric, move the material more quickly

Monofilament thread breaks

Reduce the motor speed and/or loosen the upper thread tension.

Thread breaks

Guide the fabric more consistently.

Quilting with BSR *



BSR-Function

The BSR presser foot reacts to the movement of the fabric under the foot and controls the speed of the sewing computer up to the maximum speed possible. The following applies: the faster the fabric is moved, the higher the speed of the sewing computer.

If the fabric is moved too fast, an acoustic signal (beep sound) is heard, if the Beeper is activated (see page 68).

ATTENTION!

As long as the BSR presser foot is illuminated red, adjustments like threading and changing the needle, for example, must not be carried out, as the needle will engage while fabric is moved unintentionally! Without fabric feed the BSR mode is turned off after approx. 7 seconds and the red light goes off.

Please refer to Safety Instructions!

By activating the BSR function the sewing computer sews either continuously at reduced speed (mode 1, standard), or as soon as the fabric is moved (mode 2).

BSR-function with straight stitch No. 1

This function using the BSR presser foot, allows for free-motion quilting (sewing) using the straight stitch and a pre-selected stitch length up to 4 mm. The regulated set stitch length is maintained within a certain speed, independent of the movement of the fabric.

BSR-function with zig-zag No. 2

The zig-zag can be used e.g. for thread painting. The set stitch length will **not** be maintained when sewing with the zigzag stitch, but the BSR function simplifies the application.

There are two different BSR modes

- **BSR 1-Mode** is the active standard
- the sewing computer runs continuously at a reduced motor speed, as soon as the foot control or the «Start/Stop»-button is pressed
- the sewing speed depends on the movement of the fabric
- through continuous needle movement, securing in the same position is possible without pressing an additional button

- by pressing the «BSR»-button (see page 29) the **BSR 2-Mode** is engaged
- the sewing computer will only engage if the foot control or the «Start/Stop»-button is pressed and the fabric is moved simultaneously
- the movement of the fabric determines the sewing speed
- for securing, the «Securing function»-button must be pressed
- by pressing the «BSR»-button again, mode 1 is engaged



For an even sewing start (the first stitch) the foot control must be pressed and the fabric moved simultaneously. This also applies for sewing points and straight stitching within a round form.

When resuming work with the BSR presser foot after exiting the function, the BSR mode that was active at the time of exiting the BSR function will be activated, even if the sewing computer was turned off in the meantime.

When exceeding a certain speed, adhering to regular stitch length cannot be guaranteed.

Make sure that the lens on the bottom of the BSR foot is clean (no fingerprints, etc.). Clean lens periodically with soft, slightly damp cloth.

Preparation

- lower the feed dog
- presser foot pressure may be reduced depending on the material type and thickness
- use slide-on table
- use the Free Hand System

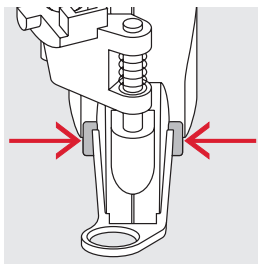

Removing the presser foot sole

- press both buttons together
- slide the sole downwards out of the groove

Attaching the presser foot sole

- slide the desired sole up in the groove until it clicks into its place

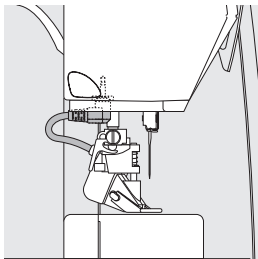

- attach the BSR presser foot to the sewing computer
- plug the cable in the outlet provided

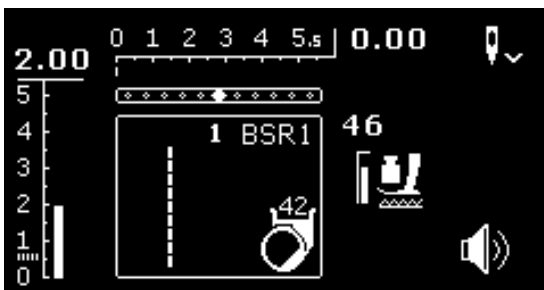

- ▶ BSR-Display is opened automatically
- ▶ straight stitch is activated
- ▶ BSR 1 mode is engaged
- select the zig-zag or the straight stitch again by pressing the «Direct Selection»-button

- set the desired stitch length
 - the basic stitch length is 2 mm
 - when sewing small forms and stippings, stitch length of 1-1.5 mm is suggested

Functions in the BSR mode

Needle stop down (default)

- ▶ the arrow points down on the BSR-Display
- ▶ the sewing computer stops with needle down, when taking foot off foot control or engaging the «Start/Stop»-button

Needle stop up

- press the «Needle stop»-button
- ▶ the arrow points up
- ▶ the sewing computer stops with needle up, when taking foot off foot control or engaging the «Start/Stop»-button

Raise or lower the needle

- press «Needle stop»-button
- ▶ to raise or to lower the needle

Securing with the «Start/Stop»-button (only Mode 1)

- place the fabric under the presser foot
- lower presser foot
- press the «Needle stop»-button twice
 - ▶ the lower thread is brought up
- hold upper and lower thread
- press the «Start/Stop»-button
 - ▶ BSR mode is activated
- sew 5-6 securing stitches
- press the «Start/Stop»-button
 - ▶ BSR mode is deactivated
- cut threads
- press the «Start/Stop»-button
 - ▶ BSR mode is activated
- continue the stitching process

Securing function (only Mode 2)

- press the «Securing function»-button
 - press either the foot control or the «Start/Stop»-button
- By moving the fabric some short securing stitches are sewn, then the set stitch length will be activated and the securing function will be automatically deactivated.

Beeper (Acoustic Signal) Activation/Deactivation

- select the «Setup»-Program
- select the icon «BSR Beep» via the «Navigation»-buttons
- press the «OK»-button to confirm
- select left icon
- press «OK»-button to confirm
 - ▶ Beeper is activated
- select right icon
- press «OK»-button to confirm
 - ▶ Beeper is deactivated
- press the «Back»-button
 - ▶ the main menu appears
- press «BSR»-button
 - ▶ the BSR-Display appears (mode 1 or 2)
- when the Beeper is activated, the signal is heard as soon as the sewing computer sews at maximal speed
- when the BSR mode is quit, the Beeper keeps the current setting (activated or deactivated)

Activating the BSR Sewing Function

Option 1:

BSR-Function via the foot control

- plug in the foot control
- lower the presser foot
- press the foot control
- ▶ BSR mode starts
- ▶ a red light appears on the presser foot
- press foot control while sewing
- the speed of the sewing computer is regulated by the movement of the fabric
- release the foot control
- ▶ the BSR mode is stopped

Option 2:

BSR-Function via the «Start/Stop»-button

- lower the presser foot
- press «Start/Stop»-button
- ▶ BSR mode is activated
- ▶ a red light appears on the presser foot
- the speed of the sewing computer is regulated by the movement of the fabric
- press the «Start/Stop»-button again
- ▶ BSR mode is stopped

Deactivating the BSR Sewing Function by using the «Start/Stop»-button Mode 1

If the fabric is not moved for approx. 7 seconds, the BSR mode is deactivated and the red light on the presser foot goes off.

Mode 2

If the stitching process is ended by no longer moving the fabric, **one** additional stitch is made, depending on the needle position. The sewing computer always stops with needle up, even if the arrow on the display points down.

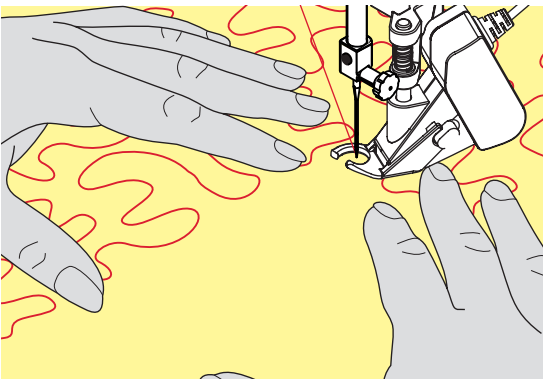

Holding the work

- both hands hold and guide the fabric like a hoop
- abrupt movements (slowing down resp. speeding up) can result in slightly too short or too long stitches
- continuous movement (no abrupt movements) will provide best results
- do not pivot the fabric while sewing



Quilt gloves with rubber fingertips will help when guiding the work.



Application example:

- BSR with zig-zag No. 2
- the zig-zag can be used for thread painting
- areas can be filled and therefore forms or pictures can be created

BSR Function deactivation

- pull out the plug of the BSR presser foot connection cable on the sewing computer
- remove the BSR presser foot

Alphabets



- press «Home»-button

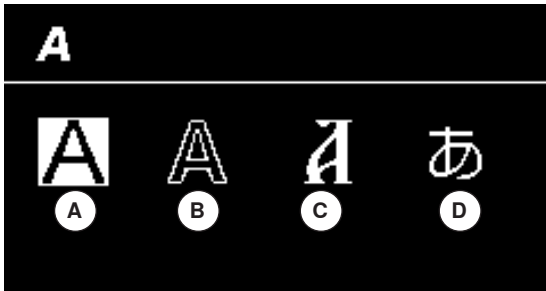

- select the «Alphabet»-icon on the Main Display via the «Navigation»-buttons
- press the «OK»-button to confirm
- ▶ the Alphabet Display providing the following four alphabets appears:
 - A Block alphabet
 - B Double Block alphabet
 - C Cyrillic alphabet
 - D Hiragana



- select the desired alphabet via the «Navigation»-buttons
- press the «OK»-button to confirm
- ▶ the character set appears

Combi mode/memory

Programming practical stitches/decorative stitches/alphabets

100 stitch patterns, lettering or numbers can be combined and saved in the combi mode/memory. The memory is long term. The contents are kept until they are deleted by the user. A power cut or switching off the sewing computer does not have any effect on the stored contents. Alterations concerning stitch length or stitch width as well as needle position can be made at any time. Single stitch patterns, lettering or numbers can be deleted or added.



- press «Home»-button



- select the «Combi mode»-icon via the «Navigation»-buttons
- press the «OK»-button to confirm

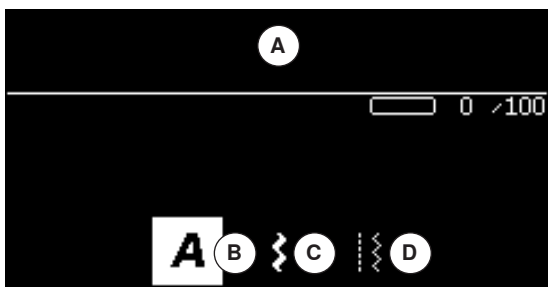

- A Edit-area
- B Alphabets
- C Decorative stitches
- D Practical stitches

- select the desired category and the desired stitch pattern
- press the «OK»-button to confirm

Stitch patterns can also be selected via the «Direct Selection»-buttons.

Application of the «Navigation»-buttons within one stitch pattern category/alphabet

- press and hold one of the «Navigation»-buttons
 - ▶ quick scrolling through the stitch pattern category/alphabet
- press the «right»-button at the end of the line
 - ▶ the first pattern of the next line is activated
- press the «left»-button at the beginning of the line
 - ▶ the last stitch pattern of the previous line is activated
- press the «right»-button at the end of the alphabet/stitch category
 - ▶ the first pattern of the alphabet/stitch category is activated
- press the «left»-button at the beginning of the alphabet/stitch category
 - ▶ the last pattern of the alphabet/stitch category is activated
- ▶ stitch pattern in the last row is activated
- press the «down»-button
 - ▶ letter/stitch pattern at the same position in the first row is activated
- ▶ the letter/stitch pattern in the first row is activated
- press «up»-button
 - ▶ the cursor jumps to the Edit-area



- ▶ the entered stitch patterns/letters are displayed in the Edit-area 1
- ▶ the cursor indicates where the desired stitch pattern/letter is added
- ▶ to the **right** of the cursor you can add, to the **left** of the cursor you can delete
- ▶ the number 2 of the active stitch pattern is shown
- ▶ if the complete combination can't be displayed, it will be indicated by arrow symbols on the right and on the left of the combination
- scroll through the combination via the «Navigation»-buttons «right/left»
- ▶ the occupied memory locations 3 are indicated
- jump from the selected category to the Edit-area and back via the «Navigation»-buttons «up/down»

These stitch patterns and programs can't be programmed:

- Securing program No. 5
- Darning program No. 22
- Basting stitch No. 30
- Buttonholes
- Button sew-on program No. 60
- Eyelets No. 61, No. 62

Sewing a combination

Creating a combination.

- press the «Back»-button twice
- ▶ the Combi-mode-Display appears
- select the «Needle»-Symbol
- press the «OK»-button to confirm
- ▶ the Sewing Display of the combi mode appears
- sew combination
- you can scroll through the combination via the «Navigation»-buttons
- ▶ the displayed stitch pattern can be edited (e.g. mirroring etc.)

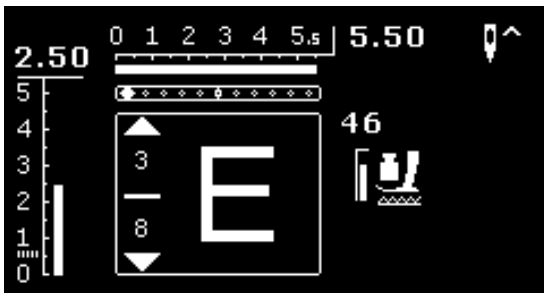

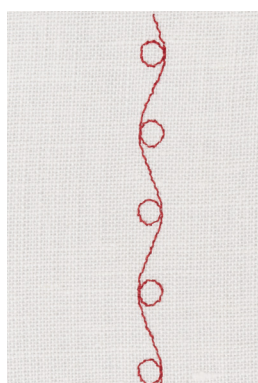

Example A

Continued sewing of the stitch pattern combination.

- select the «Combi mode», see page 71
- select decorative stitches
- press the «OK»-button to confirm
- select the stitch pattern No. 711 in category 700
- press the «OK»-button to confirm
- press the «Back»-button
- select the stitch pattern No. 407 in category 400
- press the «OK»-button to confirm
- press the «Back»-button twice
- choose the sewing mode
- press the «OK»-button to confirm
- sew combination

Example B

Combining stitch pattern and «Mirroring»-Function and sewing continuously.

- select the «Combi mode», see page 71
- select decorative stitches
- press the «OK»-button to confirm
- select stitch pattern No. 730 in category 700
- press the «OK»-button to confirm
- select the stitch pattern No. 730 again
- press the «OK»-button to confirm
- press the «Back»-button twice
- choose the sewing mode
- press the «OK»-button to confirm
- select the second stitch pattern via the «Navigation»-button «down»
- press the «Mirror image»-button
- press the «Pattern begin»-button
- sew combination



Combinations of decorative stitches sewn with embroidery thread

- stitch patterns appear fuller
- thread the bobbin thread into the bobbin finger for best results

Pattern combination on two layers of fabric

Bottom layer does not pucker.

Pattern combination on a single layer of fabric

- always use a (adhesive) stabilizer or a tissue paper as a backing
- remove stabilizer or tissue paper after sewing

Example C

Programming lettering/numbers.

- select «Combi mode»-icon
- select desired alphabet and enter the text
- press the «Back»-button twice
- choose the sewing mode
- press the «Securing»-button
- ▶ the sewing computer sews securing stitches at the beginning of the entered combination
- sew the combination
- press the «Securing»-button while sewing
- ▶ the sewing computer sews securing stitches at the end of the entered combination and stops
- trim connecting threads after sewing

Correcting the combination



Delete the complete combination

- press «Home»-button
- select the «Combi mode»-icon via the «Navigation»-buttons
- press the «OK»-button to confirm
- ▶ the Combi-mode-Display appears
- select the «Delete»-icon
- press the «OK»-button to confirm
- ▶ the complete combination is deleted



Deleting a single stitch pattern/letter

- press the «Navigation»-button «up» until the cursor is in the Edit-area
- place the cursor to the right of the stitch pattern/letter to be deleted via the «Navigation»-buttons «right/left»
- press the «clr»-button
- the stitch pattern/letter to the **left** of the cursor is deleted



Adding stitch patterns/letters

- press the «Navigation»-button «up» until the cursor is in the Edit-area
 - place the cursor at the desired position via the «Navigation»-buttons «right/left»
- Adding the stitch pattern/letter at the beginning of a combination.
- place the cursor to the «left» of the first stitch pattern/letter via the «Navigation»-buttons
 - press the «Navigation»-button «down»
 - select the desired stitch pattern/letter in the selected category
 - press the «OK»-button to confirm
 - ▶ the stitch pattern/letter is inserted to the **right** of the cursor in the Edit-area



Leaving the combi mode/memory

- press «Home»-button
- ▶ the Main Display appears
- ▶ the combination is saved

Cleaning

ATTENTION!

Disconnect plug from the socket before cleaning or lubricating!
Never use alcohol, petrol, white spirit or any type of solvent to clean the sewing computer!



Cleaning the display and the sewing computer

Wipe with a soft, damp cloth.

Feed dog area

Clean the sewing computer after every use - remove any lint from under the stitch plate and in the hook area.

- turn power switch to «0» (off)
- pull out plug from electrical outlet
- remove presser foot and needle
- open the bobbin door
- press the stitch plate down at the right back corner until it flips up
- remove the stitch plate
- clean the area with the lint brush
- replace the stitch plate



Cleaning the hook

- turn power switch to «0» (off)
- pull out plug from electrical outlet
- remove bobbin case
- push the release lever to the left
- let down the locking lever and the black hook race cover
- remove the hook



- clean the hook race with a cloth or brush, never use a sharp instrument
- replace the hook, turning the handwheel if necessary until the hook driver is on the left
- close the hook race cover and secure with the locking lever, the locking pin must engage
- check by turning the handwheel
- insert the bobbin case



Lubricating

- turn power switch to «0» (off)
- pull out plug from electrical outlet
- squeeze 1 or 2 drops of BERNINA oil into the hook race
- turn power switch to «I» (on)
- run the sewing computer for a short time (without thread)
- ▶ this prevents the fabric from getting dirty

Troubleshooting

In most cases you will be able to identify and remedy faults by checking the following.

Check if:

- the upper and lower threads are threaded correctly
- the needle is inserted correctly
- the needle size is correct - check the needle/thread table page 24
- the needle tip and shaft are undamaged
- the sewing computer is clean - brush out any thread lint
- the hook race is clean
- any threads are trapped between the tension discs or under the bobbin case spring

Fault	Cause	Repair
Uneven stitch formation	<ul style="list-style-type: none"> – Upper thread too tight/too slack – Needle blunt or bent – Poor quality needle – Poor quality thread – Needle/thread combination is incorrect – Incorrectly threaded 	<ul style="list-style-type: none"> ■ reduce/increase upper thread tension ■ use new BERNINA quality needles ■ use new BERNINA quality needles ■ use quality thread (Isacord, Mettler, Gütermann etc.) ■ match the needle to the thread size ■ check upper and lower thread
Skipped stitches	<ul style="list-style-type: none"> – Incorrect needle system – Needle bent or blunt – Poor quality needle – Needle inserted incorrectly – Incorrect needle point 	<ul style="list-style-type: none"> ■ use needle system 130/705H ■ use new BERNINA quality needles ■ use new BERNINA quality needles ■ insert needle as far up as it will go ■ match the needle point to the texture of the fabric
Faulty stitching	<ul style="list-style-type: none"> – Remnants of thread between the tension discs – Incorrectly threaded – Remnants of thread under the bobbin case spring 	<ul style="list-style-type: none"> ■ fold a piece of thin material and slide the folded edge (not the raw edges) between the thread tension discs, moving the fabric back and forth to clean the right and left side of the thread tension ■ check upper and lower thread ■ carefully remove any thread remnants from under the spring
Thread is caught in the area of the take-up lever	<ul style="list-style-type: none"> – Upper thread breaks 	<p>If the upper thread breaks and the thread is trapped in the area of the take-up lever, proceed as follows:</p> <ul style="list-style-type: none"> ■ power switch to «0» (off) ■ remove the screw A on the headframe with the angular Torx button ■ turn headframe cover slightly to the left, then slide it upwards and remove ■ remove remnants of thread ■ attach headframe and retighten screw
Upper thread breaks	<ul style="list-style-type: none"> – Upper thread tension too tight – Incorrectly threaded – Poor-quality or old thread – Stitch plate or hook tip damaged 	<ul style="list-style-type: none"> ■ reduce upper thread tension ■ check upper thread ■ use quality threads (Isacord, Mettler, Gütermann) ■ take the sewing computer to the nearest authorized BERNINA dealer

Fault	Cause	Repair
Lower thread breaks	<ul style="list-style-type: none"> – Lower thread tension too tight – Stitch hole in the stitch plate has been damaged – Needle blunt or bent 	<ul style="list-style-type: none"> ■ increase the upper thread tension ■ take the sewing computer to the nearest authorized BERNINA dealer ■ use new needle
Needle breaks	<ul style="list-style-type: none"> – Needle not correctly inserted – Fabric was pulled – Fabric was pushed when thick material used – Poor-quality thread, unevenly wound or knotted 	<ul style="list-style-type: none"> ■ tighten the needle clamp screw ■ do not pull the fabric during sewing ■ use the correct presser foot for thick material (e.g. Jeans foot No. 8) use height compensating tool when sewing over a thick seam ■ use quality thread (Isacord, Mettler, Gütermann etc.)
Sewing computer	<ul style="list-style-type: none"> – Sewing computer fails to run or runs slowly 	<ul style="list-style-type: none"> ■ plug not properly inserted ■ power switch to «0» (off) ■ sewing computer has been standing in a cold room ■ take the sewing computer to the nearest authorized BERNINA dealer
Message Assert in File	<ul style="list-style-type: none"> – Internal calculation error 	<ul style="list-style-type: none"> ■ switch the sewing computer off and on again

Stitch Pattern Summary

BERNINA 530

Practical stitches

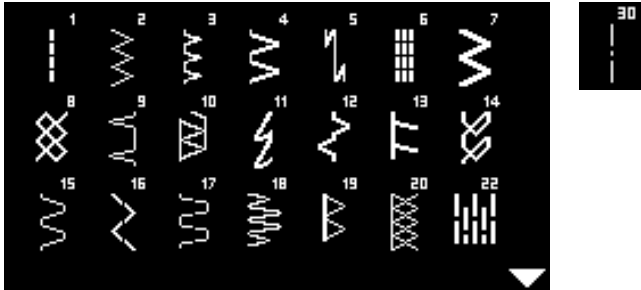

Buttonholes

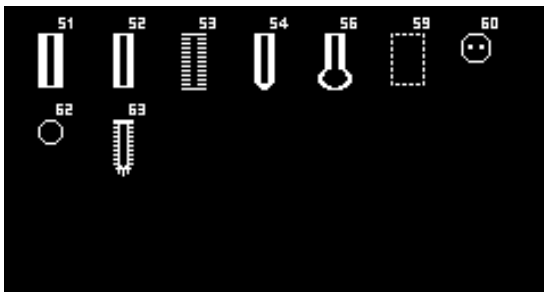

Decorative stitches

Floral stitches

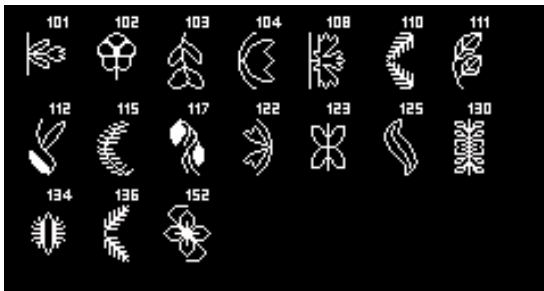

Cross stitches



Satin stitches

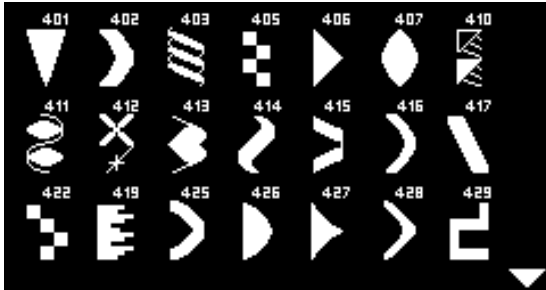

Ornamental stitches



Heirloom stitches



Novelty stitches

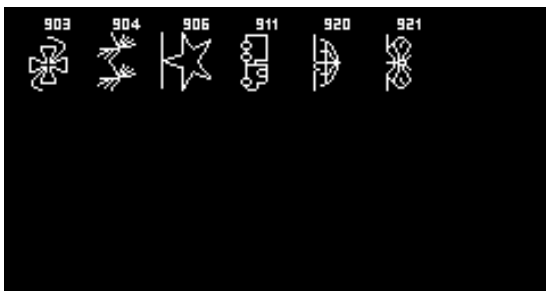

Quilt stitches

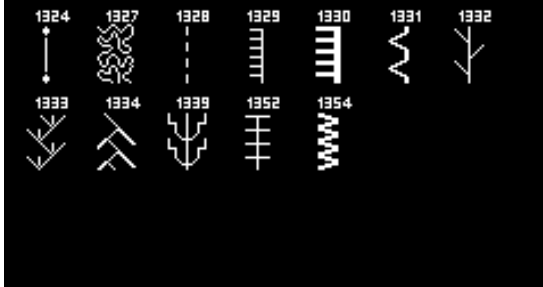

Alphabets

Block alphabet



Double Block alphabet

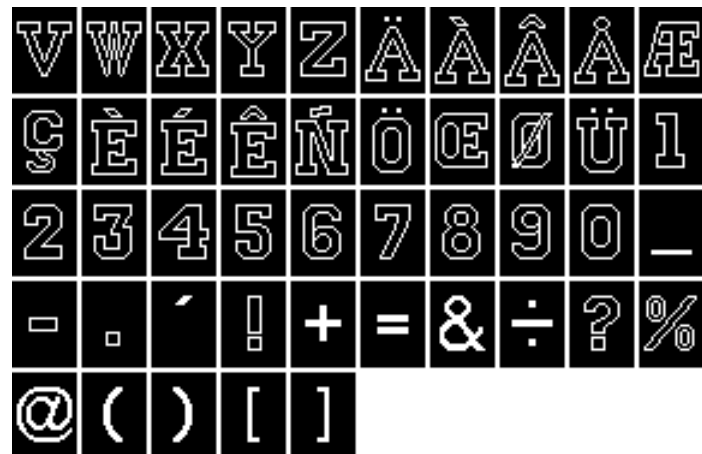

Cyrillic alphabet

А Б В Г Д Е Ё
 Ж З И Й К Л М
 Н О П Р С Т У

Ф Х Ц Ч Ш Щ Ъ Ы Ь Э
 Ю Я

Hiragana

あ い う え お か き
 く け こ さ し す せ
 そ た ち つ て と な

に	ぬ	ね	の	は	ひ	ふ	へ	ほ	ま
み	む	め	も	や	ゆ	よ	ら	り	る
れ	ろ	わ	を	ん	あ	い	う	え	お
や	ゆ	よ	つ	が	ぎ	ぐ	げ	ご	さ
じ	ず	ぜ	そ	た	ち	つ	て	ど	ば
び	ふ	へ	ほ	ぱ	び	ぷ	ぺ	ぽ	

BERNINA 550 QE

Practical stitches

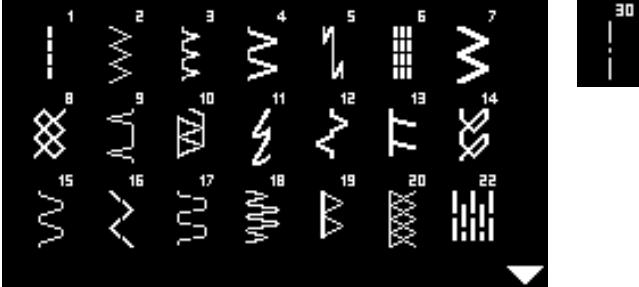

Buttonholes

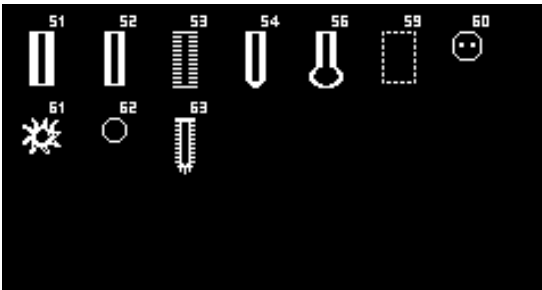

Decorative stitches

Floral stitches

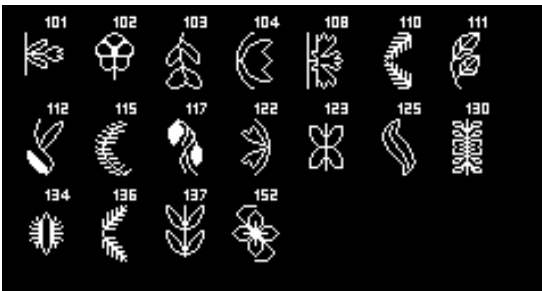

Cross stitches

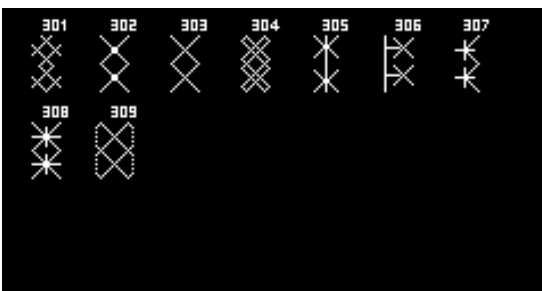

Satin stitches

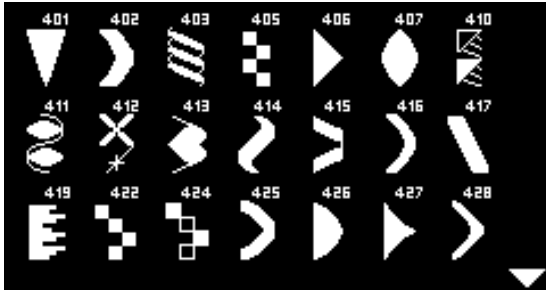

Ornamental stitches



Heirloom stitches

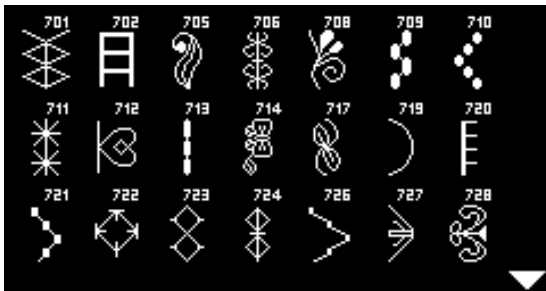

Novelty stitches

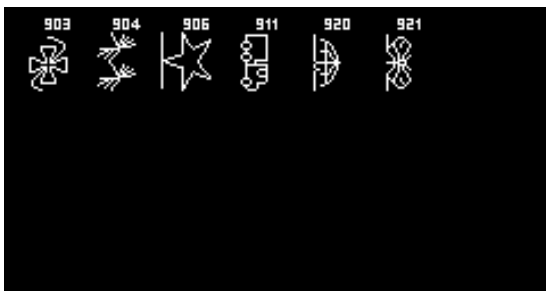

Quilt stitches

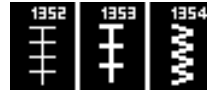
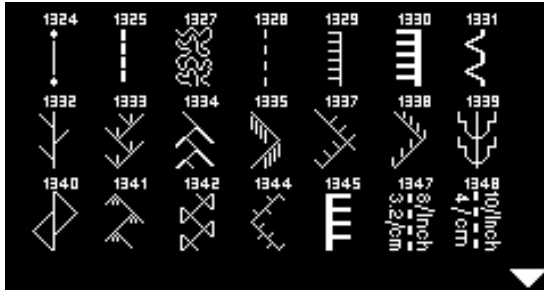

Alphabets

Block alphabet



Double Block alphabet

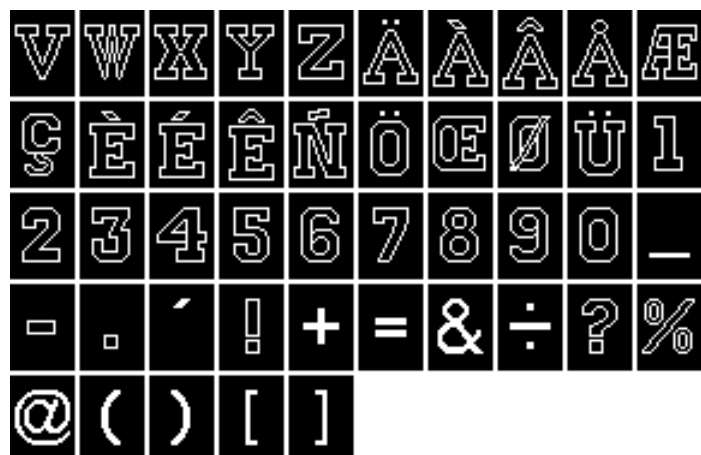

Cyrillic alphabet

А Б В Г Д Е Ё
 Ж З И Й К Л М
 Н О П Р С Т У

Ф Х Ц Ч Ш Щ Ъ Ы Ь Э
 Ю Я

Hiragana

あ い う え お か き
 く け こ さ し す せ
 そ た ち つ て と な

に	ぬ	ね	の	は	ひ	ふ	へ	ほ	ま
み	む	め	も	や	ゆ	よ	ら	り	る
れ	ろ	わ	を	ん	あ	い	う	え	お
や	ゆ	よ	つ	が	ぎ	ぐ	げ	ご	さ
じ	ず	ぜ	そ	た	ち	つ	て	ど	ば
び	ふ	へ	ほ	ぱ	び	ぷ	ぺ	ぽ	

Index

A

Accessories

- Presser foot shank/sole 8
- Presser feet 8
- Standard 7

Accessory box 9

- Possible organization 9

Alphabets 70, 80-81, 84-85

Altering

- Balance 36
- Needle position 27
- Presser foot pressure 21
- Stitch length 27
- Stitch width 27

Altering needle position 27

Altering stitch length 27

Altering stitch width 27

Altering stitches

- Practical-/Decorative stitches 39
- Length 27
- Width 27

Attaching

- Free Hand System 13
- Presser foot 19
- Presser foot sole 18
- Seam guide 12
- Slide-on table 12
- Stitch plate 19

Automatic buttonhole 56-58

Automatic heirloom buttonhole

- Programming 58

Automatic keyhole and round buttonhole

- Programming 57

Automatic standard and stretch buttonhole

- Programming 56

B

Back button 28

Balance

- Buttonhole 55
- Practical and decorative stitches 36

Basting stitch 48

Beeper 32, 33, 68

Blind hem 47

Bobbin case

- Bobbin finger 15
- Changing 15
- Inserting 15
- Removing 15

Bobbin cover 11

Bobbin thread cutter 15

Bobbin winder pre-tension 11, 14

Brightness and contrast 32

BSR 66-69

- Activating 69
- Attaching presser foot 67
- Beeper 68
- Deactivating 69
- Display 67
- Functions 68
- Modes 66
- Preparation 67
- Quilting 69
- Remove/attach presser foot sole 67
- With straight stitch No. 1 66
- With zig-zag No. 2 66

Button sew-on program 51, 60

Buttonhole 51-59

- 4-steps 59
- 5-steps 59
- Altering stitch length 52
- Altering the bead width 52
- Automatic 56-58
- Automatic buttonhole foot with slide No. 3A 8, 56
- Balance 55
- Compensation plate 52
- Cording 54
- Cutting open 54
- Duplicating 56, 57
- Height compensation tool 52
- Heirloom buttonhole 51
- Important information 51
- In long term memory 58
- Keyhole buttonhole 51
- Manual buttonhole 59
- Marking 52
- Overview 51, 78, 82
- Programming 56-58
- Round buttonhole 51
- Stabilizer 53
- Standard buttonhole 51
- Standard buttonhole narrow 51
- Straight stitch buttonhole 51
- Stretch buttonhole 51
- Test sewing 52
- Thread tension 52

C

Cable	
■ Plugging in	12
■ Unwinding/winding	12
Carrying handle	11
Changing	
■ Bobbin case	15
■ Needle	16
■ Presser foot	19
■ Presser foot shank	18
■ Presser foot sole	18
■ Stitch plate	19
Cleaning	
■ Display and sewing computer	75
■ Feed dog area	75
■ Hook	75
■ Lubricating	75
Cleaning symbol	30
clr-button	11, 29
Combi mode	71-74
■ Contents	71
■ Programming practical/decorative stitches	71-72
■ Using the «Navigation»-buttons	71
Combining	
■ Adding a stitch pattern	74
■ Correcting	74
■ Deleting a complete combination	74
■ Deleting a single stitch pattern	74
■ Examples	73
■ Sewing	72
Compensating material	50
Connection	
■ Foot control	11, 12
■ Free Hand System	11, 13
■ Power cable	11
■ Special accessory	11
Contents	5
Contrast and brightness	32
Cording	
■ Automatic buttonhole foot with slide No. 3A	54
■ Buttonhole foot No. 3	54
■ Buttonhole sole No. 3	54
■ Securing	54
Correcting	
■ Fabric layers	50
■ Height of seam	50
■ Practical-/decorative stitches	36
Cotton thread	23
Cover	
■ Thread take-up lever	11

Creative consultant

■ Overview	35
■ Recommendations	35
■ Sewing techniques	35
■ Types of fabrics	35

D**Darning**

■ Automatic	44
■ Manually	43

Darning hoop connection 11**Decorative stitches**

■ Application	62
■ Overview	62, 78-80, 82-83
■ Selecting	62

Detail view

■ Sewing computer	10, 11
-------------------	--------

Direct selection buttons 26, 38**Display**

■ Alphabets	70
■ BSR	67
■ Buttonholes	51
■ Cleaning	75
■ Combi mode	71
■ Decorative stitches	62
■ Main display/main menu	31
■ Overview	30
■ Practical stitches	31

Double overlock 45**E****Edges**

■ Top stitching	46
-----------------	----

Environmental protection 3**Examples of application**

■ Practical stitches	40-49
----------------------	-------

Eyelet

■ With small zig-zag	51, 61
■ With straight stitch	51, 61

F**Fabric feed**

■ Feed dog	22
------------	----

Feed dog

■ Fabric feed	22
■ Lowering	22
■ Position	22
■ Ready to sew	22
■ Symbol	30

FHS 13**Flat joining seam 49**

- Foam pads** 7
- Font** 70
- Foot control**
 - Unwinding/winding the cable 12
 - Connection 11, 12
 - Plugging in 12
 - Sewing speed control 12
- Free Hand System**
 - Connection 13
 - Inserting 13
 - Lower/raise presser foot 13
- Free-motion quilting** 65
- Front view**
 - Sewing computer 10
- Function buttons**
 - Back 28
 - Balance 29
 - BSR 29
 - clr 29
 - Home 28
 - Mirror image left/right 29
 - Navigation 29
 - Needle stop 29
 - OK 29
 - Pattern begin 29
 - Pattern end/pattern repeat 28
 - Quick reverse 28
 - Securing function 29
 - Speed control 28
 - Start/stop 28
 - Stitch selection 26, 38
- Functions**
 - Direct selection buttons 26
 - Needle position 27
 - Stitch category 27
 - Stitch length 27
 - Stitch selection 26, 38
 - Stitch width 27
- G**

- Glossary** 6
- Guidelines**
 - Material/thread/needle size 24
- H**

- Handlook quilt stitch** 63, 64
- Handwheel** 11
- Height compensation of uneven layers** 50
- Height compensation tool** 7, 50, 52
- Heirloom buttonhole** 58
- Hem**
 - Edges 46
 - Blind 47
 - Jersey stitch 47
 - Visible 47
- Horizontal spool pin** 11, 14, 16, 17
- I/J**

- Inserting**
 - Bobbin 15
 - Bobbin case 15
 - Free Hand System 13
 - Needle 16
 - Stitch plate 19
- Inserting a bobbin** 15
- Jersey stitch** 37
- Joining seam** 49
- K**

- Key to signs** 6
- Keyhole buttonhole** 51, 57
- L**

- Long term memory**
 - Buttonhole 58
- Lower thread**
 - Bobbin winding 14
 - Bobbin winding while sewing 14
 - Changing the bobbin case 15
 - Cutting 11, 14, 15
 - Inserting a bobbin 15
 - Threading 15
- Lubricating** 33, 34, 75
- M**

- Main menu** 31
- Main power switch** 11
- Manual buttonholes** 59
- Material, needle and thread** 23
- Materials** 35
- Memory**
 - Adding 74
 - Alphabets 71
 - Application 71
 - Corrections 74
 - Deleting 74
 - Display 72
 - Examples 73
 - Leaving 74

- Opening 71
- Programming 71-72
- Programming alphabets 71
- Programming practical and decorative stitches 71
- Stitch pattern 71
- Temporary altered stitch memory 39

Mirror image 29

Mirror image function 29

N

Navigation-buttons 29

Needle

- Changing 16
- Guidelines 24
- Holder 11
- Important facts about thread and needles 23
- Inserting/removing 16
- Needle-thread-combination 24
- Overview 25
- Position 27
- Raising/lowering 29
- Stop 29
- Threading 17, 18
- Twin and triple needles 25

Needle system 24

Needle threader 18

Needle, thread and fabric 23

Needle-thread-combination 24

O

OK-button 29

Optional accessory

- Connection 11

Overlock

- Double Overlock 45
- Stitches 37

Overview

- Alphabets 70, 80-81, 84-85
- Buttonholes 51, 78, 82
- Creative consultant 35
- Decorative stitches 62, 78-79, 82-83
- Display 30
- Function buttons 26-29
- Needle 25
- Practical stitches 37, 78, 82
- Quilt stitches 63, 80, 84
- Setup Program 32
- Sewing computer 10, 11
- Stitch patterns 78-85

P

Pattern begin 29

Pattern end/pattern repeat 28

PC-connection 11

Polyester thread 23

Power cable

- Connection 11

Practical stitches 37-50

- Blind hem 47
- Blind stitch 37
- Triple straight stitch 37, 40
- Triple zig-zag 37, 41
- Basting stitch 37, 48
- Darning manual/automatic 43, 44
- Double overlock 37, 45
- Edgestitching 46
- Flat joining seam 49
- Gathering stitch 37
- Honeycomb stitch 37
- Jersey stitch 37, 47
- Knit overlock 37
- Lycra stitch 37
- Open seam 40
- Overview 37, 78, 82
- Reinforced overlock 37
- Running stitch 37
- Satin stitch 30, 44
- Securing program 37, 48
- Selecting 26, 31
- Sewn zig-zag 37, 44
- Simple darning program 37
- Stitch selection 26, 27, 38
- Straight stitch 37, 40
- Stretch stitch 37
- Stretch-Overlock 37
- Super stretch 37
- Universal stitch 37
- Vari-overlock 37
- Zig-zag 37, 44
- Zipper 42

Preparation

- Sewing computer 12-25

Presser feet

- Standard 8

Presser foot

- Attaching/removing 19
- BSR 8
- Changing 19
- Overview 8
- Pressure 21
- Display 30
- Raising/lowering 11
- Soles 8
- Standard accessory 8

Presser foot lifter 11

Presser foot pressure			
■ Increasing/reducing		21	
Presser foot pressure-adjusting wheel		21	
Presser foot sole			
■ Changing		18	
Presser foot system		8	
Q	<hr/>		
Quick reverse			
■ Permanent		28	
■ Temporary		28	
Quilt stitches			
■ Overview		63, 80, 84	
Quilting			
■ Free-motion quilting		65	
■ Quilt stitch/hand stitch		64	
■ Stipple quilting		65	
■ With BSR		66-69	
R	<hr/>		
Rayon threads		23	
Rear thread guide		11, 16	
Reinforced overlock		37	
Reinforcing			
■ Presser foot pressure		21	
Removing			
■ Bobbin case		15	
■ Needle		16	
■ Presser foot/sole		18, 19	
■ Slide-on table		12	
■ Stitch plate		19	
Round buttonhole		51, 57	
Running stitch		37	
S	<hr/>		
Safety instructions		2	
Satin stitch		30, 44	
Seam guide			
■ As guide		46	
Seam ripper		7, 54	
Securing function button		29	
Securing program		48	
Selecting			
■ Stitch patterns		26, 38	
Selecting stitch category		27	
Service symbol			30
Setting			
■ Balance			36
■ Needle position			27
■ Presser foot pressure			21
■ Thread tension			20
Setup Program			32-33
■ Beeper for BSR			33
■ Brightness and contrast			32
■ Lubricating the sewing computer			33
■ Overview display			32
■ Software version			33
■ The basic setting			33
Sewing			
■ Accessories			7
■ Alphabets			70
■ Blind hem			47
■ Buttonhole			56-59
■ Combinations			72
■ Corners			50
■ Eyelet			61
■ Function buttons			26-29
■ Reverse sewing			11, 28
■ Sewing on button			60
■ Sewing techniques			35
■ Zipper			42
Sewing computer			
■ Cleaning			75
■ Function buttons			26-29
■ Lubricating			75
■ Overview			10, 11
■ Troubleshooting			76
Sewing corners			50
Sewing on buttons			60
Sewing speed			12, 28
Slide-on table			
■ Attaching/removing			12
Software version			33
Soles			8
Speed			
■ Controlling			28
■ Foot control			12
Spool discs			7
Spool holder			
■ Horizontal			11, 14, 16, 17
■ Vertical			11, 13
Stabilizer			53
Standard accessory			7, 8
Standard buttonhole			56

Start/Stop button	28		
Stipple quilting	65		
Stitch pattern			
■ Overview	78-85		
■ Selecting	26, 38		
■ Temporary altered stitch memory	39		
Stitch pattern selection			
■ Menu selection	27, 38		
■ Stitch number	26, 38		
Stitch plate			
■ Cleaning	75		
■ Inserting/attaching	19		
■ Markings	19		
■ Removing	19		
Stitch selection			
■ Direct selection buttons	26, 38		
Straight stitch	37, 40		
Stretch buttonhole	56		
Stretch-overlock	37		
Submenu	31		
System settings			
■ Balance	36		
■ Creative consultant	35		
■ Setup program	32-33		
■ Tutorial	34		
T			
Temporary altered stitch memory			
■ Long term	39		
■ Temporary	39		
Tension	20		
The basic setting			
■ Presser foot pressure	21		
■ Sewing settings	33		
■ Thread tension	20		
Thread			
■ Important facts about thread and needles	23		
■ Needle-Thread-Combination	24		
Thread cutter			
■ On bobbin winder	14		
■ Lower thread	15		
■ On Head Frame	18		
Thread guide at the back	11, 16		
Thread take-up cover	11		
Thread tension			
■ Adjustment wheel	20		
■ Buttonhole	52		
■ Stitch pattern	20		
■ The basic setting	20		
■ Upper thread	20		
Threader	18		
Threading			
■ Lower thread	15		
■ Double needle/triple needle	17		
■ Needle	18		
■ Upper thread	16		
Threading the triple needle	17		
Threading the double needle	17		
Top stitching			
■ Edges	46		
■ Narrow/wide	46		
Top stitching of outer edges	46		
Triple straight stitch	40		
Triple zig-zag	41		
Troubleshooting	76-77		
Tutorial	34		
U			
Upper thread			
■ Tension	20		
■ Threading	16		
V			
Vari-overlock	37		
Vertical spool pin	11, 13		
Z			
Zig-zag	44		
Zipper			
■ Sewing	42		
■ Sewing both sides	42		

Text

Herbert Stolz/Susanne Ribi

Graphics

www.sculpt.ch

Pictures

Patrice Heilmann, CH-Winterthur

Typesetting, Layout

Susanne Ribi

Copyright

2011 BERNINA International AG, CH-Steckborn

In partnership with

AMANN
GROUP

Mettler®

