

Border Set

RULER KIT

With Fabric Gripping Action®

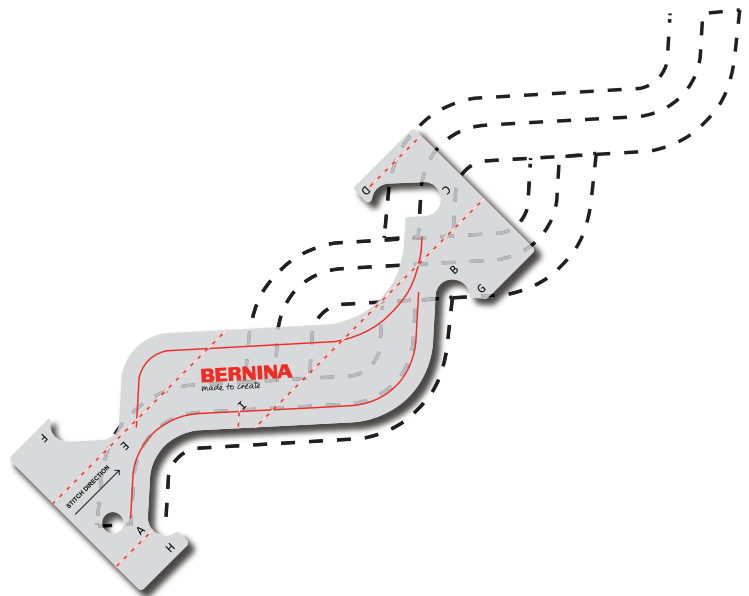
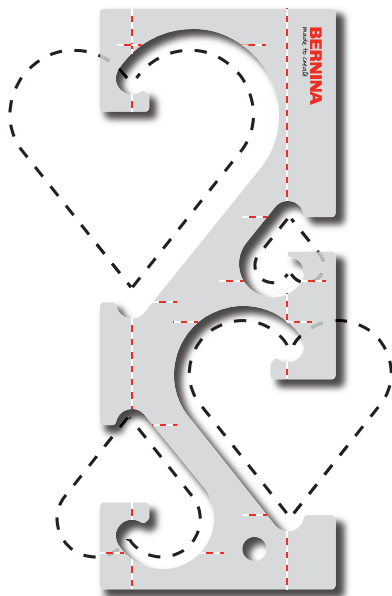
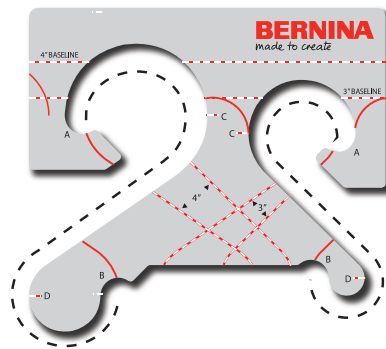

BERNINA *made to create*

Further languages:
Weitere Sprachen:
Autres langues:
Otros idiomas:



Pointed Leaf/Oval Instructions

These tools are designed for machine quilting using either a home machine or a longarm. If you are using the tools on a machine that moves, be sure to have a ruler base attached to your machine. The dimensions of these tools are designed with the #72 or #96 ruler foot in mind. The tools have registration lines for ease in aligning the tool to create designs.

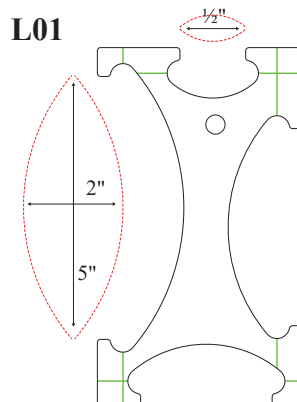

Create A Wave

1) Using either a line drawn (or chalked) on the quilt or a seam, you can create a simple wave. Use the printed lines in the tool to align the chosen size leaf/oval over the seam or line. Stitch from one end of the opening to the other. Needle Down.

2) Swing the tool around the foot (using the foot as a pivot point) until the dashed lines are again lined up on the quilt. Stitch from one end of the opening to the other. Needle Down.

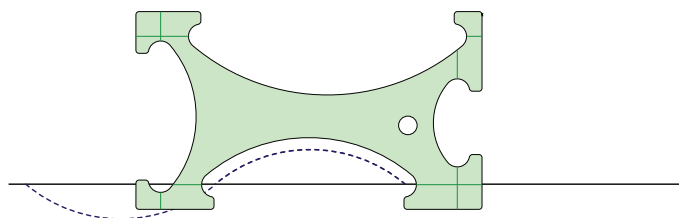
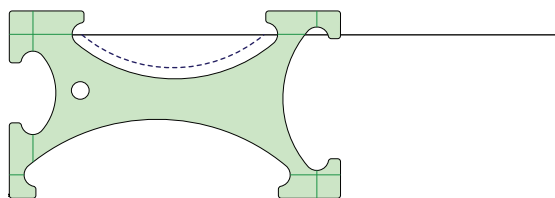

3) Repeat until wave is desired length.

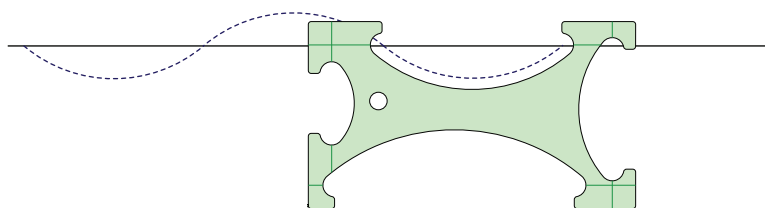

Create a Simple Chain

- 1) Start by creating a wave.
- 2) To create a chain, repeat the wave steps on the opposite side of your wave. (See illustration)

LEAF/OVAL #1

Step 1

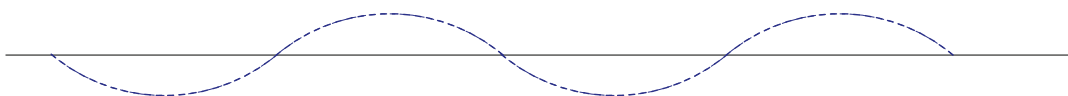

Create a Simple Chain (continued)

Step 2

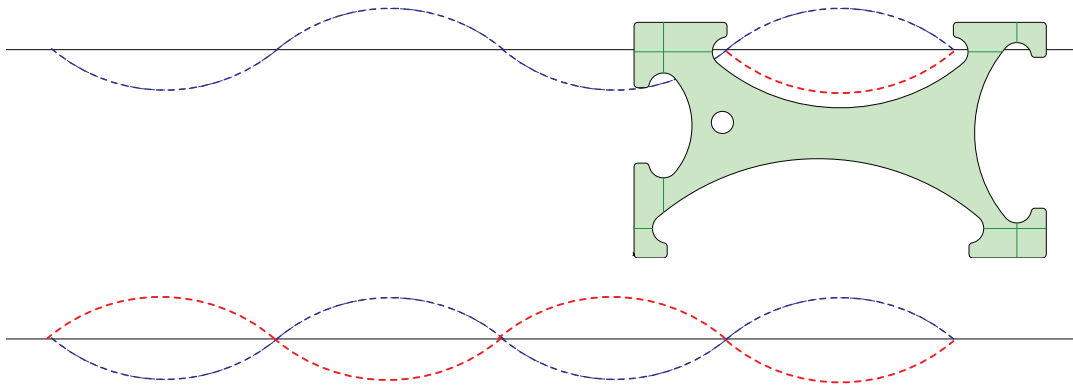

Multiple Sizes

Use multiple sizes of the tool to create a chain with multiple size links.

LEAF/OVAL #1: Step 1

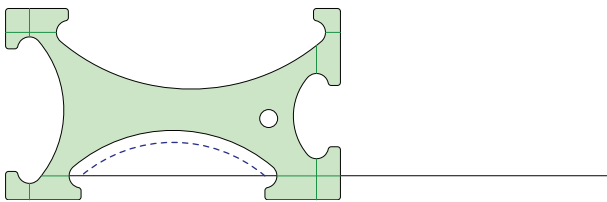

Step 2

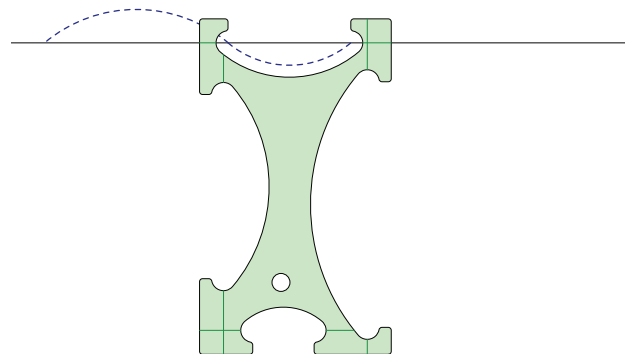

Step 3

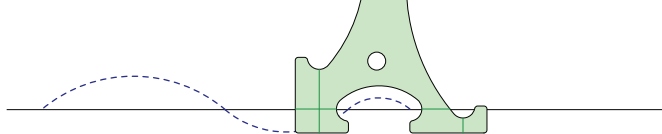

Step 4

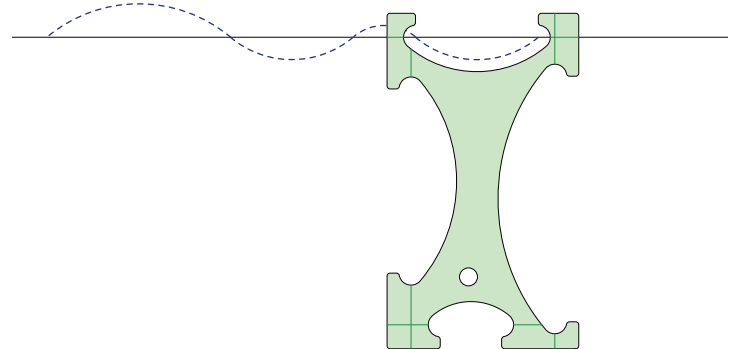

Step 5

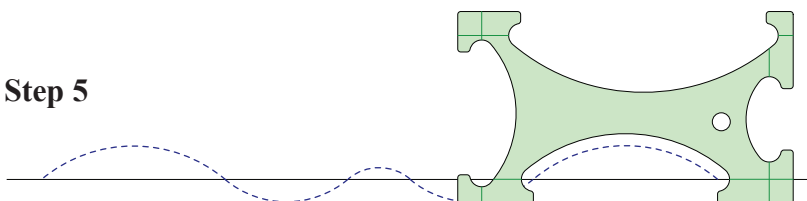

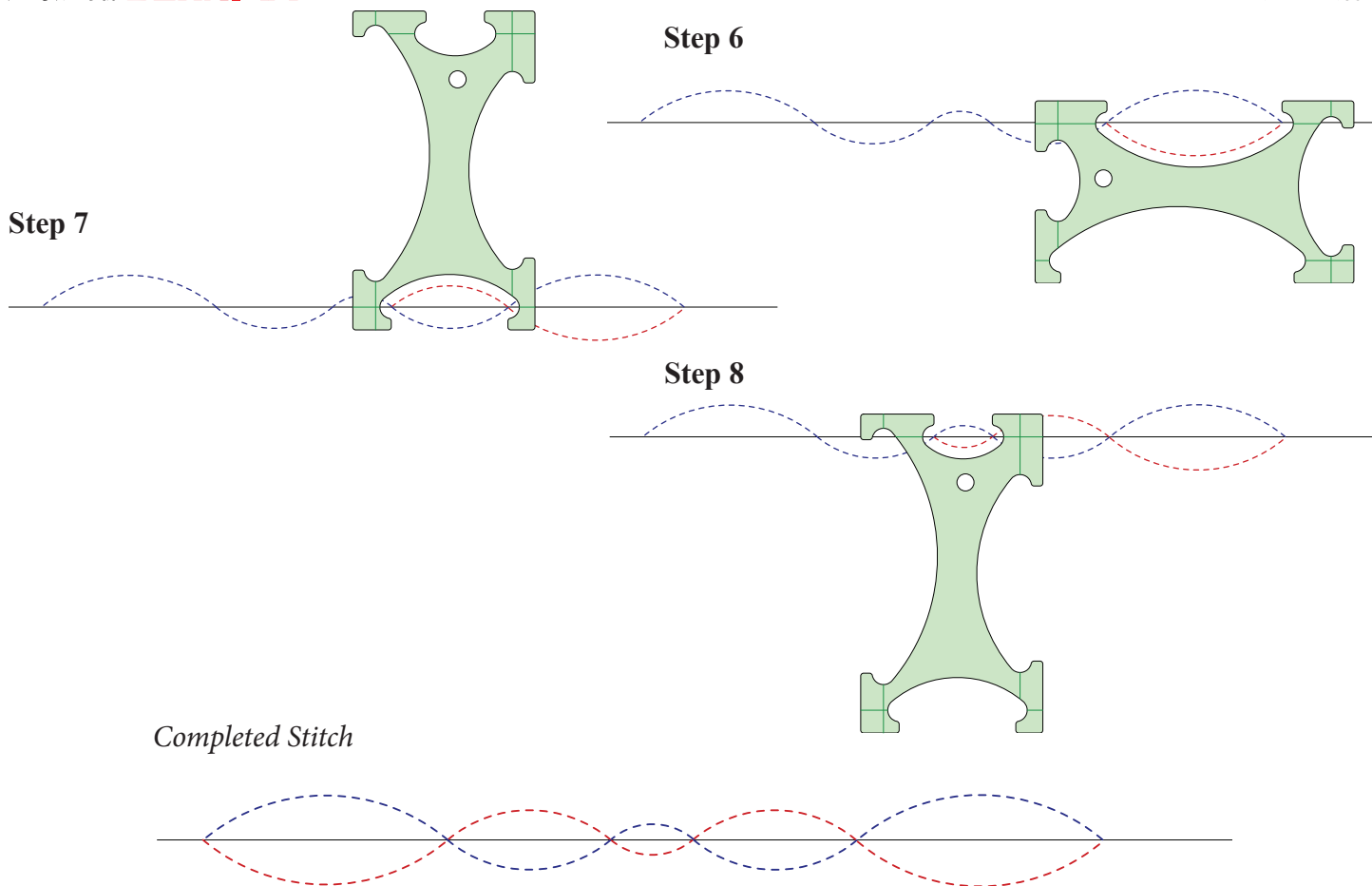

Simple Star Variation

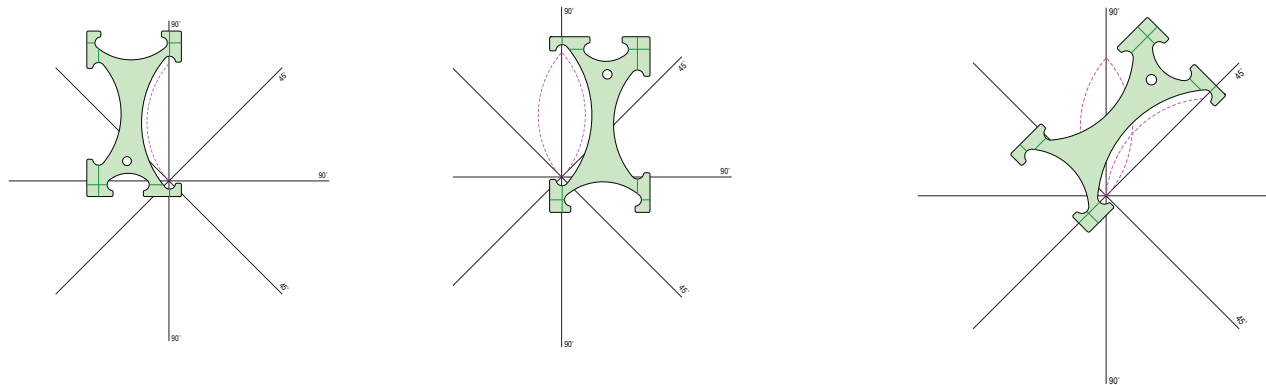

1) Draw or chalk an eight point grid on your block. With your foot at the center, hook one end of an opening around the foot lining up the opposite end on the drawn line. Stitch from the center to the outer edge. Needle down.

2) Flip the tool around the foot lining up the registration lines on the tool with the lines on the block. Stitch from the outer edge to the center. Needle down.

3) Rotate to the next line and repeat.

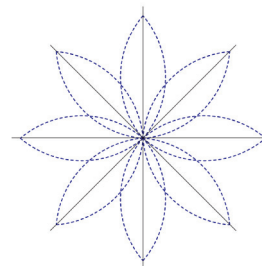

Completed star

ADDITIONAL LEAF/OVAL DESIGNS

For more instructions please visit bernina.com/bordersrulers.

Interlocking Chain

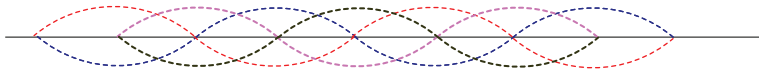

Star Variations

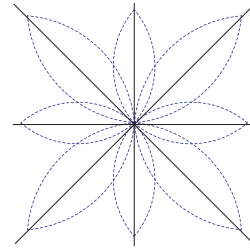

Chain Variations

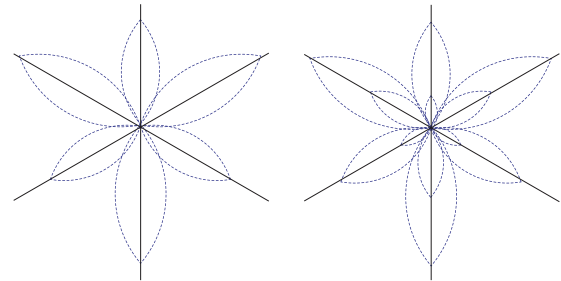
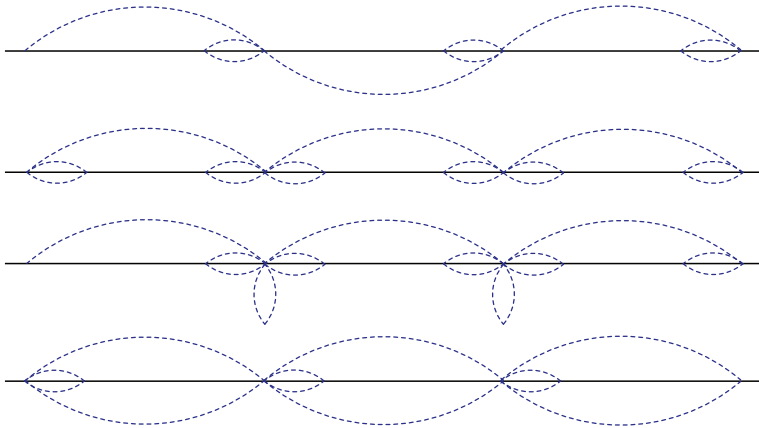

Flame Chain

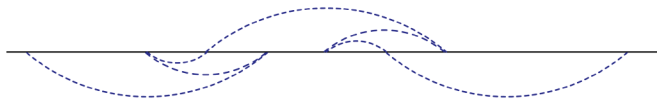

Cable Variation

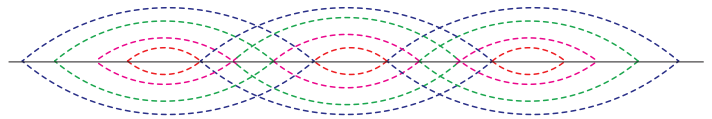

Umbrella

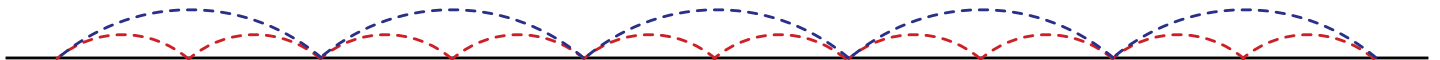

Apostrophe

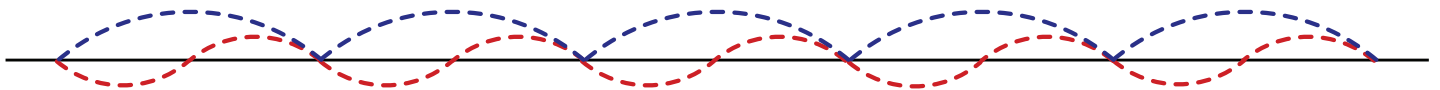

Continuous 3 Arc Interlock

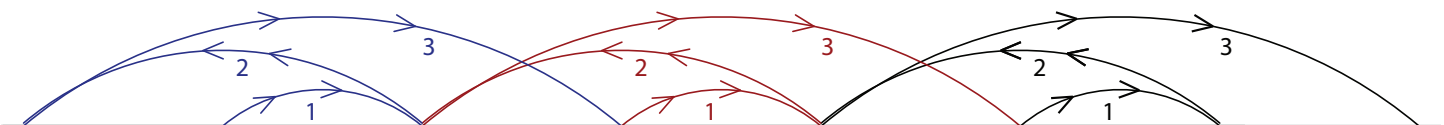

Cable Tool Instructions

This tool is designed to create a 3" cable with 3 lines.

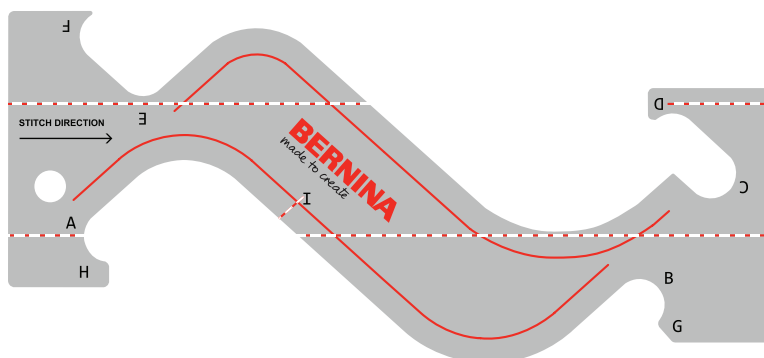

Create a Cable Stitch

1) Using either a line drawn (or chalked) on the quilt border, you can create a 3" cable stitch. Use the printed dashed lines in the tool to align on the drawn line. Make sure the stitch direction arrow is pointed in the direction of travel. Stitch from point A to point B. Needle Down.

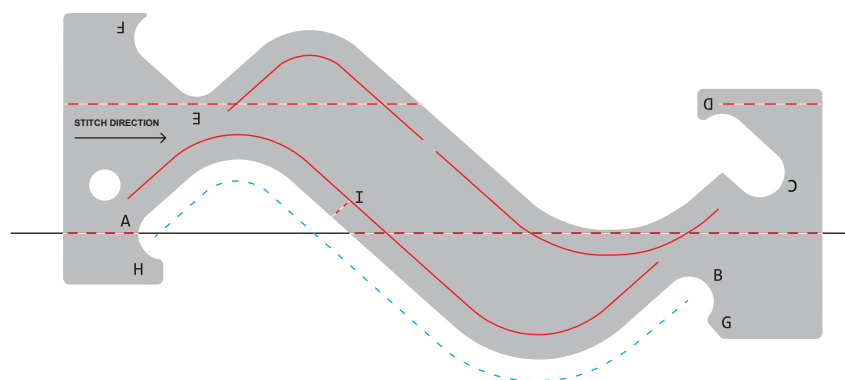

2) Move template to hook C onto the foot and align the dashed line with the line. Stitch from C to D. Be sure to stitch to D and not just around the point (if you stitch around the point you will not have a crisp cable join). Continue to stitch from D to E, then E to F. Needle Down.

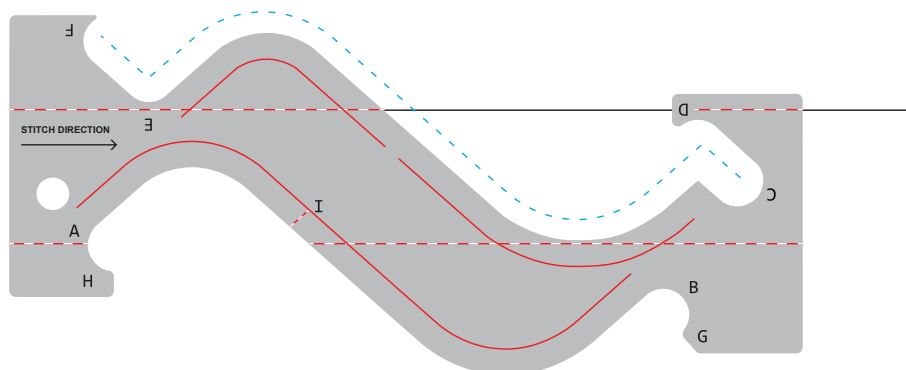

Cable Stitch (continued)

3) Flip the template to line G up with your foot. Line up previous stitch line on solid printed line and dashed line on drawn line. Stitch from G to H, then back stitch to I. Needle down.

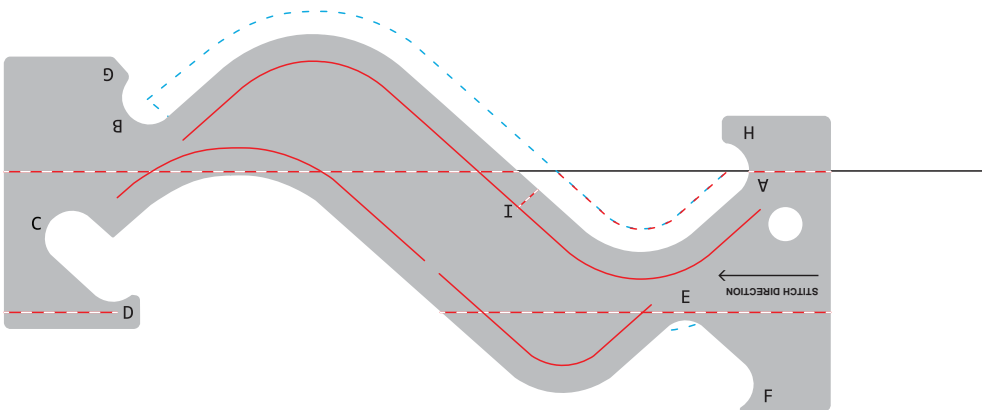
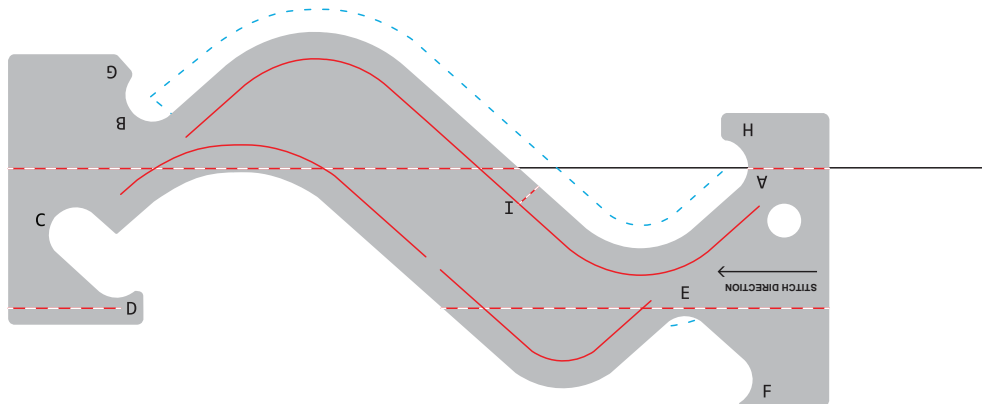

4) Flip template and line up on A. Repeat steps 1 through 4 to finish the cable stitch.

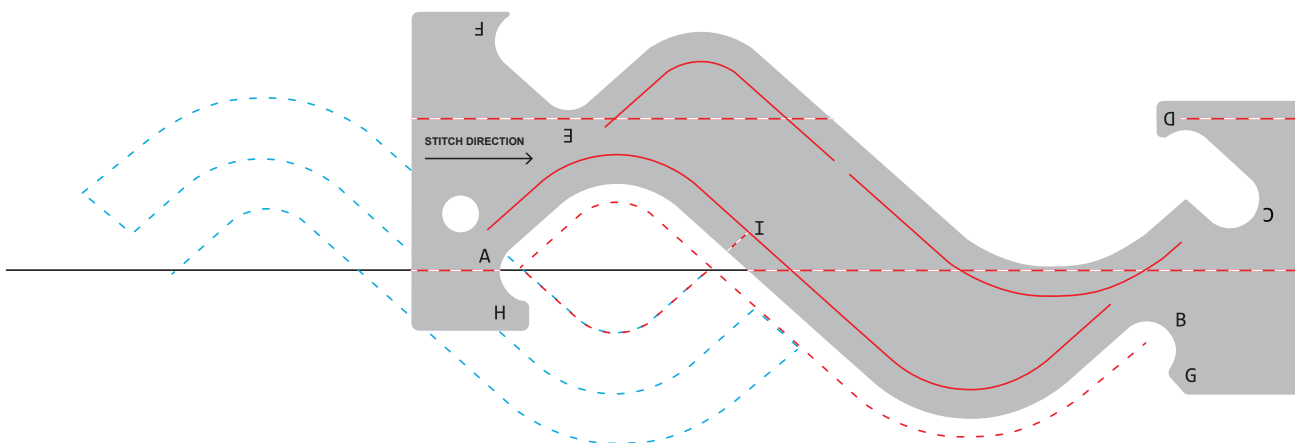

5) Completed cable stitch.

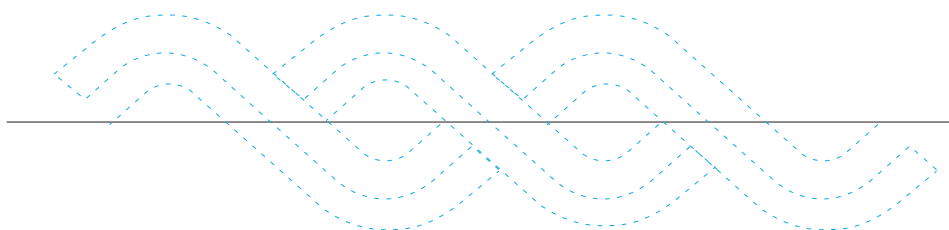

Loop-to-Loop Instructions

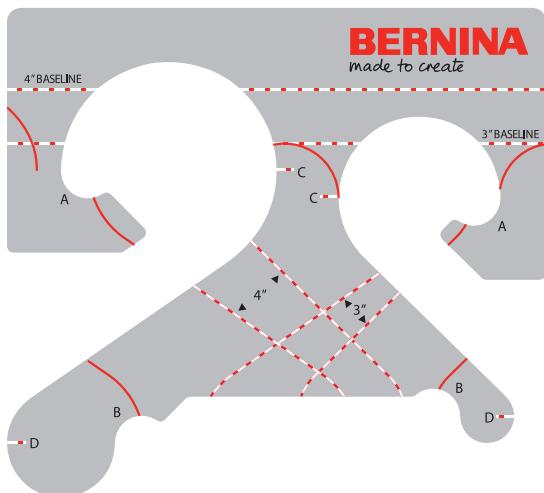

The Loop-to-Loop tool is designed to allow machine quilters to quilt a series of continuous loops along a border. This tool will make 3" and 4" loop-to-loop designs.

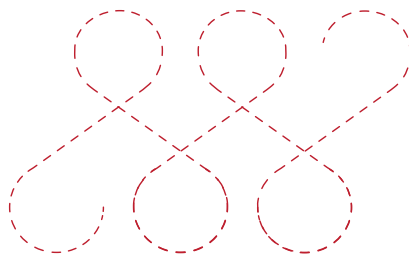

Note: As this design uses both the Fabric Gripping Action® side (bottom) and the non-Fabric Gripping Action® side (top), you may want to spray with Grippy or apply sticky dots to top side.

Create a Loop-to-Loop Chain

1. Use a line drawn (or chalked) on the quilt or a seam to create a Loop-to-Loop chain design. Use the dashed base line on the tool to align the chosen size loop on the drawn line or seam.
2. Starting at point A, sew to point B. Needle down.
3. Flip the Loop-to-Loop tool horizontally. Align the baseline on the tool on the drawn line or seam with the foot at D on the tool.
4. Continue to sew from point D to point A (the crook of the tool). Needle down.
5. Flip the Loop-to-Loop tool horizontally. Align the baseline on the tool on the drawn line or seam with the foot at C on the tool.
6. Continue to sew from point C to point B. Needle down.
7. To continue the loop design, repeat the steps 4-6 until border is filled.

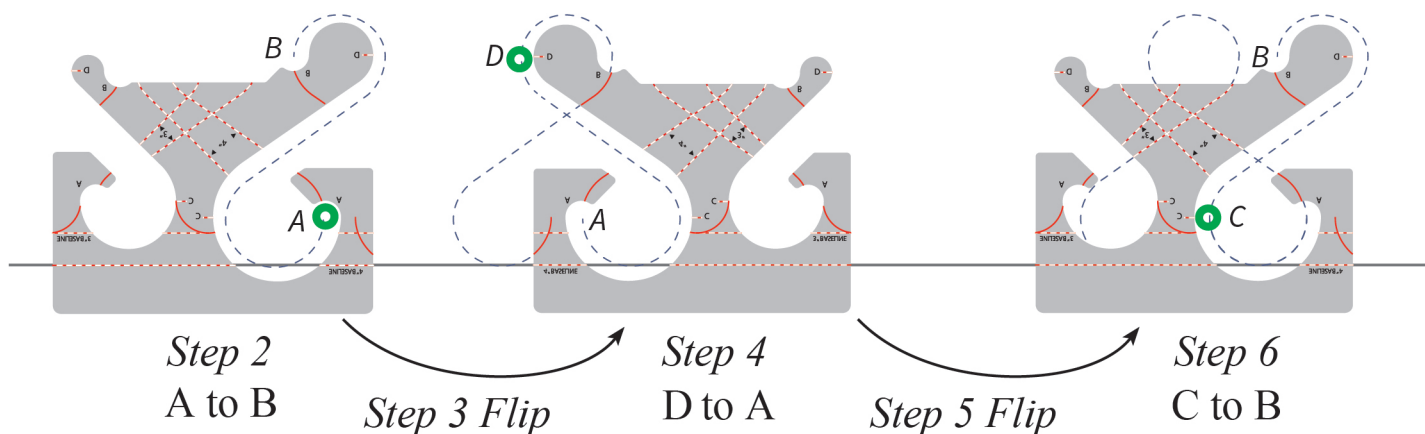

Create High & Low Circles

1. Use a line drawn (or chalked) on the quilt or a seam to create the high/low circles design. Use the front straight edge of the tool to align the chosen size loop over the drawn line or seam. (*Tip 1*)
2. Starting at point A, sew to point B. Needle down.
3. Flip the Loop-to-Loop tool over vertically. Align the front straight edge of the tool on the drawn line or seam with the foot at B.
4. Continue sewing from point B to point A. Needle down.
5. Flip the Loop-to-Loop tool over vertically. Align the front straight edge of the tool on the drawn line or seam with the foot at A.
6. Continue sewing from point A to point B. Needle down.
7. To continue the high/low circles design, repeat the above steps.

Tip 1: Use either edge as a guide.

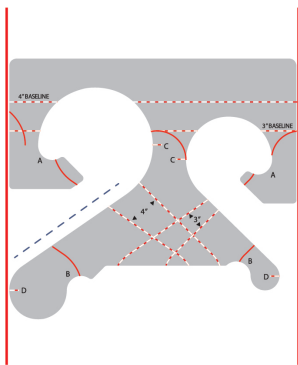

Tip 2: To create a vertical registration line on the tool somewhere other than the edge, use a piece of blue painter's tape.

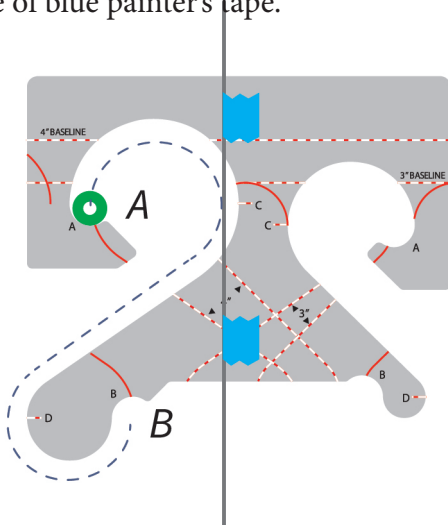

Step 2
A to B

Step 3
Flip

Step 4
B to A

Step 5
Flip

Step 6
A to B

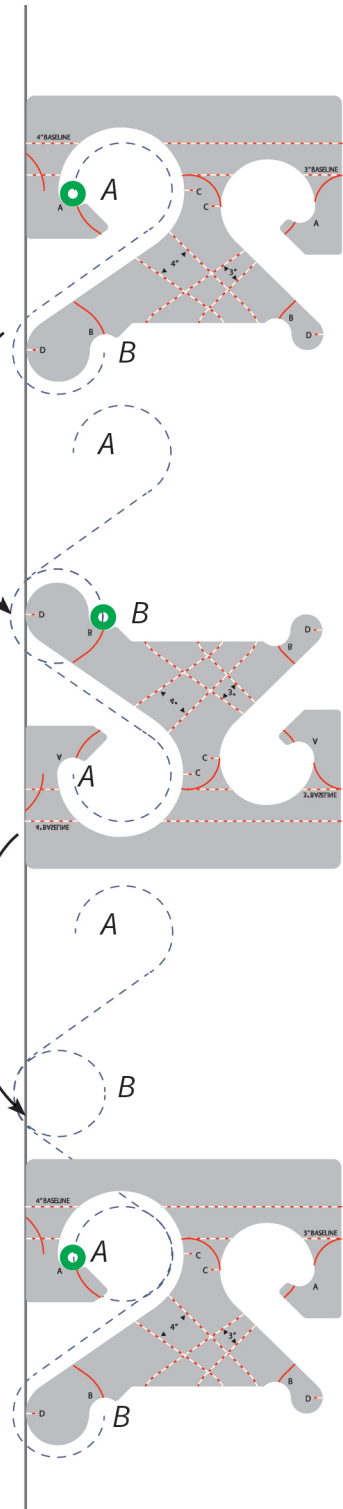

Note: As this design uses both the Fabric Gripping Action® side (bottom) and the non-Fabric Gripping Action® side (top), you may want to spray with Grippy or apply sticky dots to top side.

Create an “S” Chain

1. Use a line drawn (or chalked) on the quilt or a seam to create an “S” chain design. Use the baseline of the tool to align the chosen size loop over the drawn line or seam.
2. Starting at point A, sew to point B. Needle down.
3. Slide the Loop-to-Loop tool sideways until the tool touches the foot at D. Align the baseline on the Loop-to-Loop tool on the drawn line or seam.
4. Sew from point D to point B, then stitch from B to A and backtrack to C. Needle down.
5. Slide the Loop-to-Loop tool sideways until the tool touches the foot at A. Align the baseline on the tool on the drawn line or seam.
6. Sew from point A to point B. Needle down.
7. To continue the “S” chain design, repeat steps 4, 5, and 6.

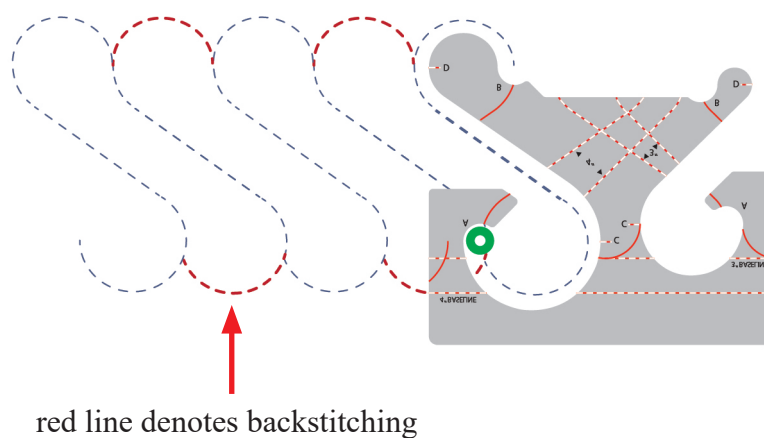
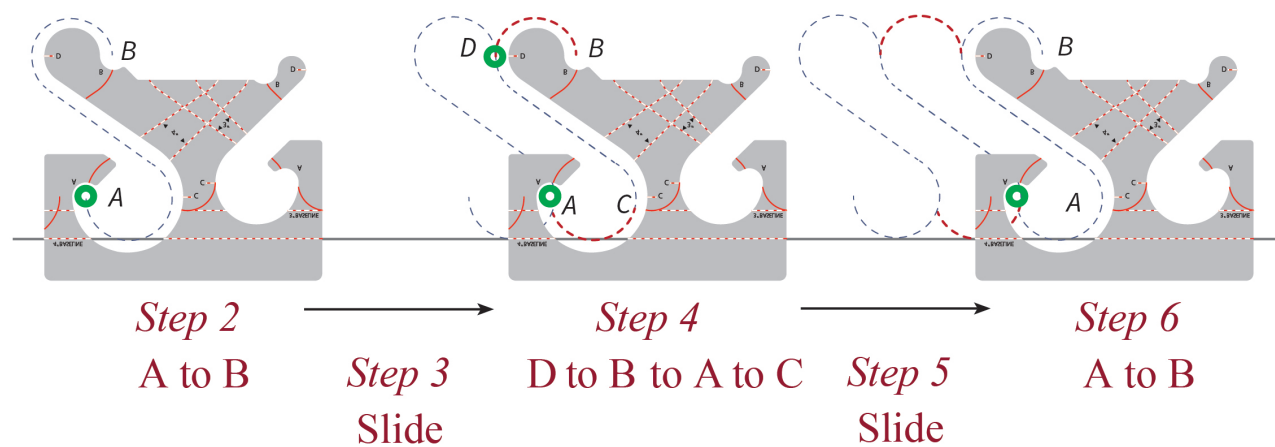

Traditional Heart Instructions

The Traditional Heart Tool is designed to allow machine quilters to quilt a heart with a point at the valley AND the tip. This tool will make 1", 2", 3" and 4" hearts.

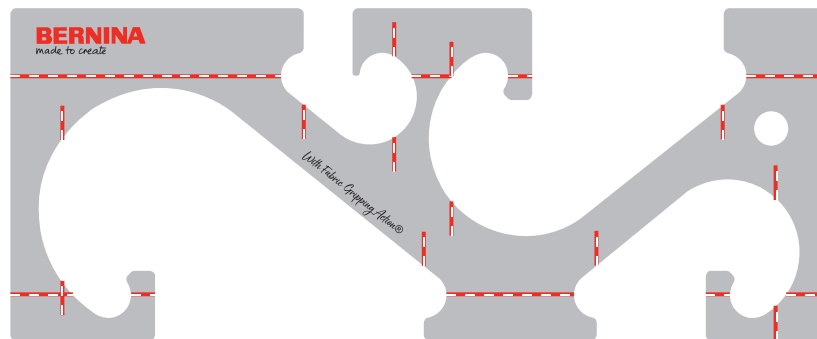

Create a Basic Heart

1. Use either a line drawn (or chalked) on the quilt or a seam to create a basic heart. Use the dashed lines on the tool to align the chosen size heart over the line or seam.
2. Starting at the valley of the heart, sew to the tip of the heart. Needle down.
3. Flip the Heart template over. Start from the tip and stitch to the valley for a complete heart.

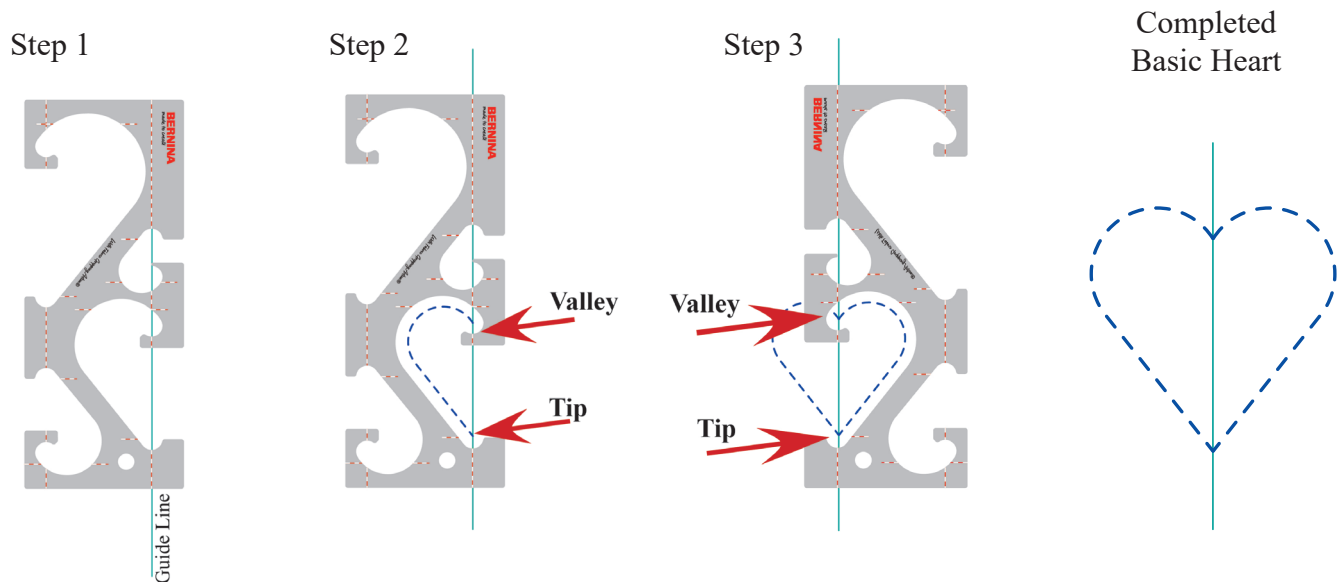

Create a Vertical Heart Border

1. For vertical borders, simply stitch half of the heart on the way down the border and finish the heart on the way up.
2. Mark a center guide line on border. Aligning the template's dashed lines with guide line, start at the valley and stitch to the tip. Needle down.
3. Slide template down so the hopping foot is at the valley, stitch from the valley to the tip. Continue these steps until you complete the length of the border. Needle down.
4. To complete the heart; flip the template and stitch from the tip to the valley. Continue until all the hearts are completed.

Create a Vertical Heart Border (continued)

Step 1

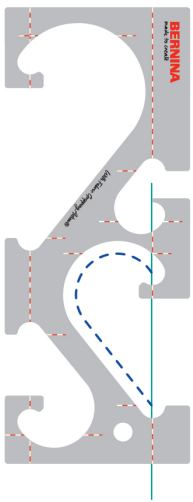

Step 2

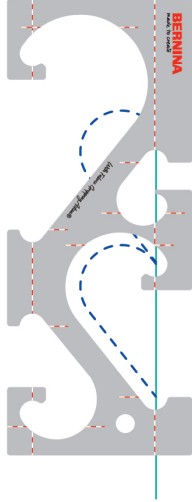

Step 3

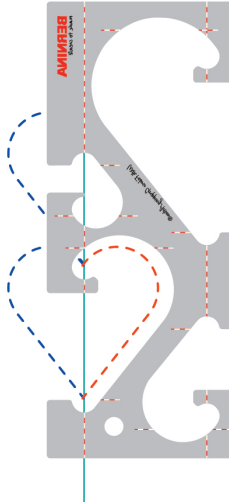

Step 4

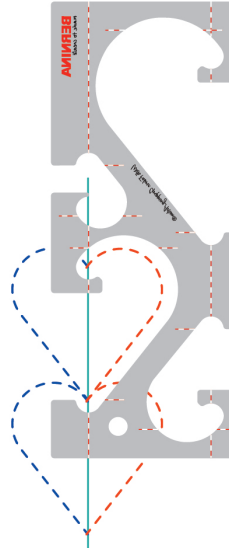

Completed Border

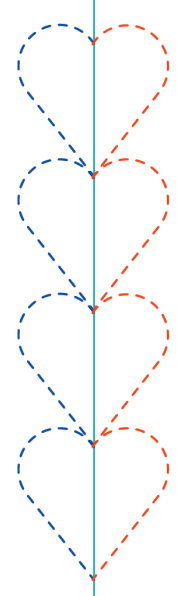

ADDITIONAL HEART DESIGNS

For more instructions please visit bernina.com/bordersrulers.

Graduating Heart Border

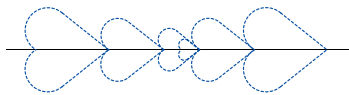

Hanging Hearts

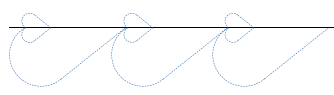

Interlocking Hearts

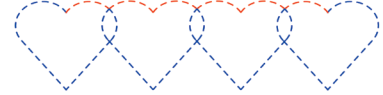

GET ALL THREE RULER KITS!

ESSENTIALS KIT

MULTI CURVE GUIDE



NESTED CIRCLES

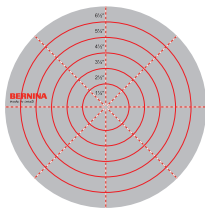

SQUIGGLE #1

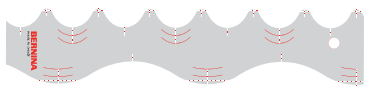

MINI STRAIGHT LINE



BORDER KIT

POINTED LEAF/OVAL



LOOP TO LOOP

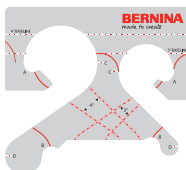

CABLE



HEARTS

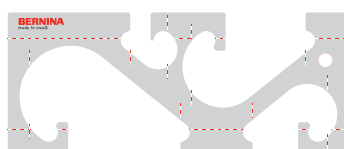

CURVES & CLAMS

CLAMSHELL X4

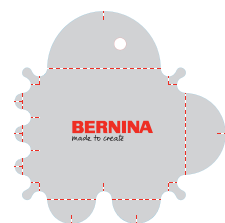

SMALL S-SHAPE



NESTED MINI OVALS

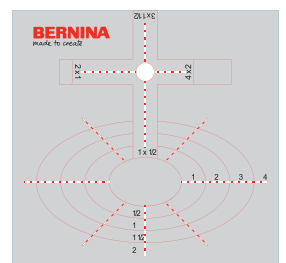

SQUIGGLE #3

