

bernette
sublime

my
city

my
bernette



London 7
London 8

Instruction Manual

IMPORTANT SAFETY INSTRUCTIONS

When using an electrical appliance, basic safety precautions should always be followed, including the following:

Read all instructions before using this sewing machine. Keep the instruction at a suitable place close to the machine, and hand it over if you give the machine to a third party.

DANGER

To reduce the risk of electric shock:

1. An appliance should never be left unattended when plugged in.
2. Always unplug this appliance from the electric outlet immediately after using and before cleaning.

WARNING

To reduce the risk of burns, fire, electric shock, or injury to persons:

1. This appliance is not intended for use by persons (including children) with reduced physical, sensory or mental capabilities, or lack of experience and knowledge, unless they have been given supervision or instruction concerning use of the appliance by a person responsible for their safety.
2. Do not allow to be used as a toy. Close attention is necessary when this appliance is used by or near children and infirm persons.
3. Use this appliance only for its intended use as described in this manual. Use only attachments recommended by the manufacturer as contained in this manual.
4. Children should be supervised to ensure that they do not play with the appliance.
5. Never operate this appliance if it has a damaged cord or plug, if it is not working properly, if it has been dropped or damaged, or dropped into water. Return the appliance to the nearest authorized dealer or service center for examination, repair, electrical or mechanical adjustment.
6. Never operate the appliance with any air openings blocked. Keep ventilation openings of the sewing machine and foot controller free from accumulation of lint, dust, and loose cloth.
7. Keep fingers away from all moving parts. Special care is required around the sewing machine needle.
8. Always use the proper needle plate. The wrong plate can cause the needle to break.
9. Do not use bent needles.
10. Do not pull or push fabric while stitching. It may deflect the needle causing it to break.
11. Switch the sewing machine off ("O") when making any adjustments in the needle area, such as threading needle, changing needle, threading bobbin, or changing presser foot, and the like.
12. Always unplug sewing machine from the electrical outlet when removing covers, lubricating, or when making any other user servicing adjustments mentioned in the instruction manual (pull power plug).
13. Never drop or insert any object into any opening.
14. Do not use outdoors.
15. Do not operate where aerosol spray products are being used or where oxygen is being administered.
16. To disconnect, turn all controls to the off ("O") position, then remove plug from outlet.

17. Do not unplug by pulling on cord. To unplug, grasp the plug, not the cord.
18. If the supply cord fixed with foot controller is damaged, it must be replaced by the manufacturer or its service agent or a similar qualified person in order to avoid a hazard.
19. Never place anything on the foot control.
20. This sewing machine is provided with double insulation (except U.S.A / Canada). Use only identical replacement parts. See instructions for Servicing of double-insulated products.

SERVICING OF DOUBLE-INSULATED PRODUCTS

In a double-insulated product, two systems of insulation are provided instead of grounding. No grounding means is provided on a double-insulated product nor should a means for grounding be added to the product. Servicing a double-insulated product requires extreme care and knowledge of the system and should only be done by qualified service personnel. Replacement parts for a double-insulated product must be identical to those parts in the product. A double insulated product is marked with the words "DOUBLE INSULATION" or "DOUBLE INSULATED".

The symbol  may also be marked on the product.

SAVE THESE INSTRUCTIONS

This sewing machine is intended for household use only.

ENVIRONMENTAL PROTECTION



BERNINA is committed to the protection of the environment. We strive to minimize the environmental impact of our products by continuously improving product design and our technology of manufacturing.

Do not dispose of electrical appliances as unsorted municipal waste, use separate collection facilities.

Contact your local government for information regarding the collection systems available.

If electrical appliances are disposed of in landfills or dumps, hazardous substances can leak into the groundwater and get into the food chain, damaging your health and well-being.

When replacing old appliances with new ones, the retailer is legally obligated to take back your old appliance for disposal at least for free of charge.

LED RADIATION

Do not view directly with optical instruments
Class 1M LED product

**Attention:**

This sewing machine is intended for household use only. If used intensively or commercially, regular cleaning and especially attentive care is required.

Signs of wear and tear owing to intensive or commercial use are not covered automatically, even if they occur within the warranty period. The decision on how to deal with any such cases rests with the local authorised servicing staff.

All rights reserved

For technical and product improvement reasons, the sewing computer's features, parts and accessory are subject to unannounced changes and alterations at any time. The accessory included can differ from country to country.

Safety Instructions	1	Basic Sewing Procedures	35
Contents	4	Useful Skills	35
Machine Overview	5	Straight Stitches and Needle Position	37
Detail of the Machine	5	Zigzag Stitches	37
Accessories - model London 7	6	Stretch Stitch	38
Accessories - model London 8	7	Overcasting Stitches	39
Machine Setup	8	Blind Hem	40
Connecting the Machine	8	Button Sewing	41
Foot Control	8	Buttonhole Stitching	42
Sewing Table	9	Eyelet Stitch	45
Push-Push Top cover	10	Darning Stitch	46
Stitch selector wheel	10	Zipper Insertion	48
Winding the Bobbin	11	Invisible zipper insertion	50
Inserting the Bobbin	13	Narrow Hemming	51
Threading the Upper Thread	14	Cording	52
Needle Threader	16	Satin Stitch Sewing	53
Replacing the Needle	17	Quilting	54
Thread Cutter	17	Fagoting	56
Thread Tension	18	Scallop Stitch	56
Adjusting Presser Foot Pressure	18	Gathering	57
Changing the Presser Foot	19	Smocking	58
Two-Step Presser Foot	20	Free Motion Darning, Embroidery and Monogramming	59
To Raise or Drop the Feed Dog	20	Walking Foot	61
Important Sewing Information	21	Special Functions	62
Needle, Fabric, Thread Selection Guide	21	Mirror Stitch Pattern - model London 8	62
Presser Foot Application Chart- model London 7	22	Twin Needle Sewing - model London 8	63
Presser Foot Application Chart- model London 8	23	Memory - model London 8	65
Display Explanation & Operating Instructions	24	Warning Functions	78
Buttons Explanation - model London 8	24	Maintenance	79
Information on the LED Display	25	Cleaning	79
Function Buttons	28	Replacing the LED Lamp	79
General Operating Principles	30	Trouble Shooting	80
Stitches Overview	32	Trouble Shooting Guide	80
		Appendix	82
		Flow Chart Normal Mode	82
		Flow Chart Memory Mode	83

Detail of the Machine

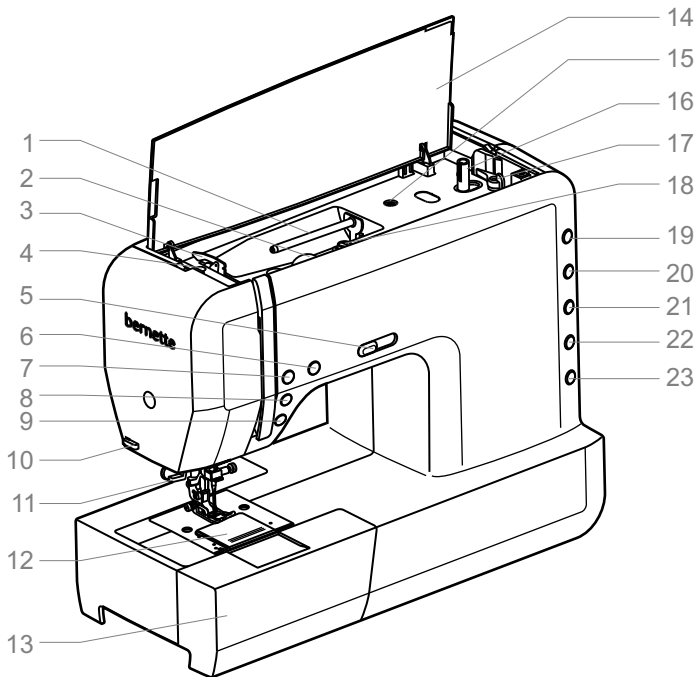

1. Spool pin
2. Thread tension dial
3. Thread guide
4. Presser foot pressure screw
5. Slide speed
6. Start/stop button
7. Auto-lock button
8. Needle up/down button
9. Reverse button
10. Thread cutter

11. Needle threader
12. Needle plate cover
13. Sewing table and accessory box
14. Top cover
15. Hole for second spool pin
16. Bobbin winder
17. Bobbin stopper
18. Bobbin winder pre-tension
19. Pattern group selection button
20. Stitch length button
21. Stitch width button

22. Function button (model London 8)
23. Memory button (model London 8)

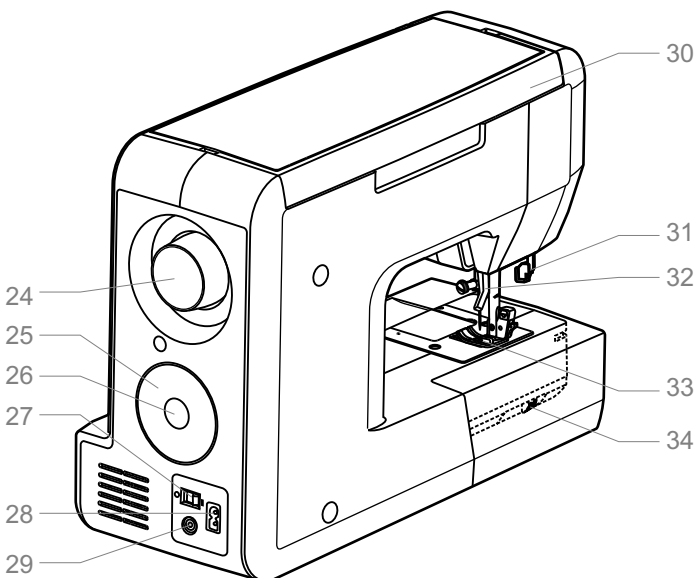

24. Handwheel
25. Selector wheel
26. Set/dispatch button
27. Power switch
28. Mains plug socket
29. Foot controller socket
30. Handle
31. One step buttonhole lever
32. Presser foot lever
33. Presser foot
34. Drop feed lever

Accessories - model London 7

Standard

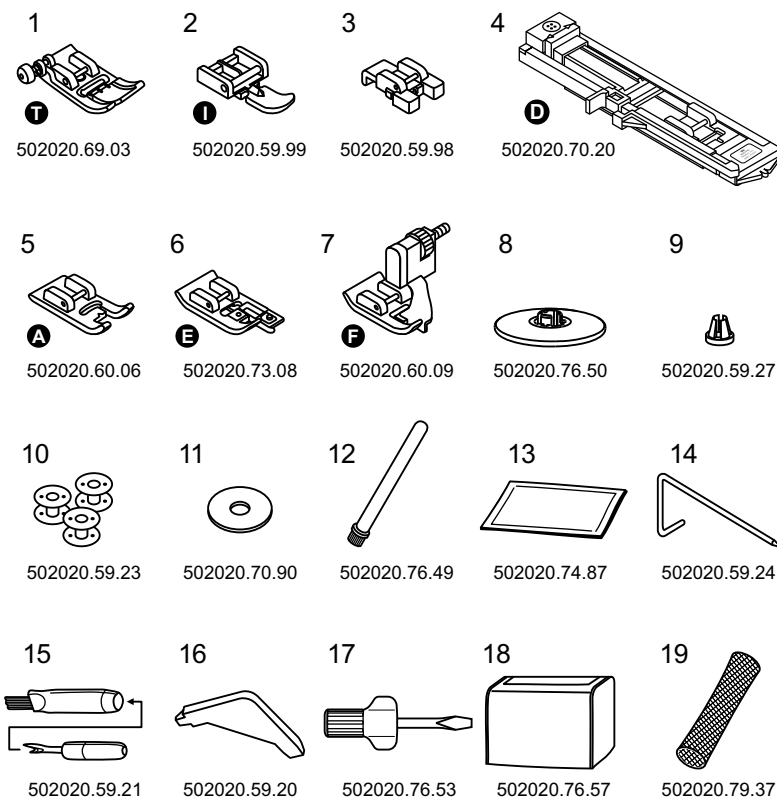

1. All purpose foot (T)
2. Zipper foot (I)
3. Button sewing foot
4. Buttonhole foot (D)
5. Satin stitch foot (A)
6. Overcasting foot (E)
7. Blind hem foot (F)
8. Spool holder (Large)
9. Spool holder (Small)
10. Bobbin (3x)
11. Spool pin felt
12. Second spool pin
13. Pack of needles
14. Edge/quilting guide
15. Brush/ Seam ripper
16. Screwdriver
17. L-Screwdriver
18. Dust cover
19. Spool net (2x)



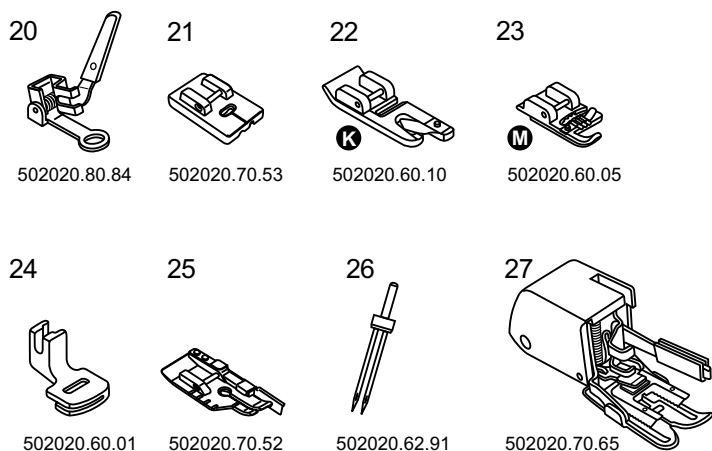







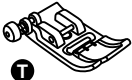

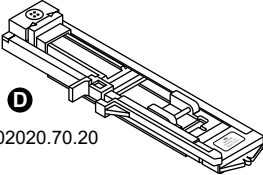
Optional (to be purchased individually)

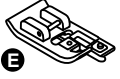
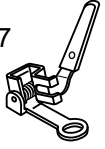
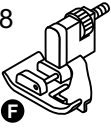



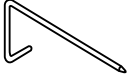
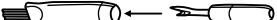

20. Darning/ Embroidery foot
21. Invisible Zipper foot
22. Hemmer foot (K)
23. Cording foot (M)
24. Gathering foot
25. 1/4" Quilting foot
26. Twin needle
27. Walking foot

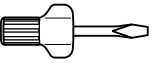
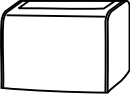
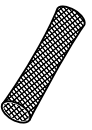
Accessories - model London 8

Standard

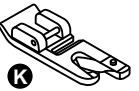
- | | | | | | |
|---|---|--|--|---|--------------------------|
| 1

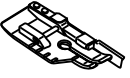
502020.69.03 | 2

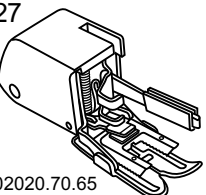
502020.59.99 | 3

502020.59.98 | 4

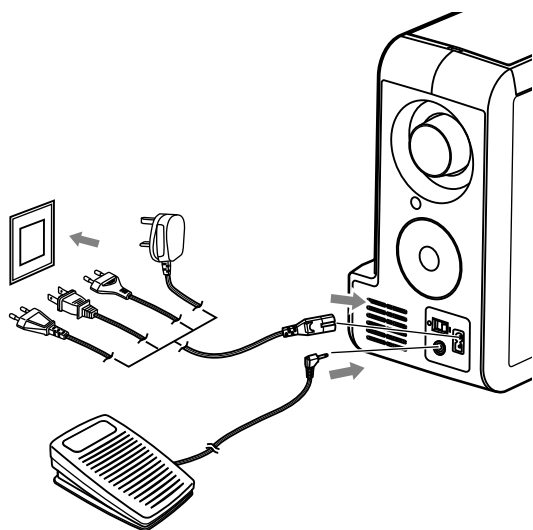
502020.70.20 | 1. All purpose foot (T) | |
| 5

502020.60.06 | 6

502020.73.08 | 7

502020.80.84 | 8

502020.60.09 | 9

502020.76.50 | 2. Zipper foot (I) |
| 10

502020.59.27 | 11

502020.59.23 | 12

502020.70.90 | 13

502020.76.49 | 14

502020.74.87 | 3. Button sewing foot |
| 15

502020.59.24 | 16

502020.59.21 | 17

502020.59.20 | 18

502020.76.53 | 15. Edge/quilting guide | 4. Buttonhole foot (D) |
| 19

502020.76.57 | 20

502020.79.37 | | | 16. Brush/ Seam ripper | 5. Satin stitch foot (A) |

Optional (to be purchased individually)

- | | | | | |
|--|---|---|---|---------------------------|
| 21

502020.70.53 | 22

502020.60.10 | 23

502020.60.05 | 24

502020.60.01 | 21. Invisible Zipper foot |
| 25

502020.70.52 | 26

502020.62.91 | 27

502020.70.65 | | 22. Hemmer foot (K) |

Connecting the Machine



Before connecting the power supply, make sure that the voltage and frequency shown on the rating plate is conforming with your mains power.

Place the machine on a stable table.

1. Connect the power line cord to the machine by inserting the 2-hole plug into the mains plug socket.
2. Connect the power line plug to the wall outlet.
3. Turn on the power switch.
4. The sewing lamp will light up when the switch is turned on.

⚠ Caution:

Always make sure that the machine is unplugged from power source and the main switch is on "O". when the machine is not in use and before inserting or removing parts.

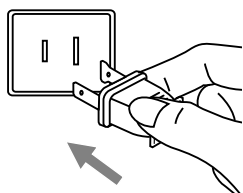

Polarized plug information

This appliance has a polarized plug (one blade wider than the other), to reduce the risk of electrical shock; this plug will fit in a polarized outlet only one way. If the plug does not fit fully in the outlet, reverse the plug. If it still does not fit, contact a qualified electrician to install the proper outlet. Do not modify the plug in any way.

Foot Control

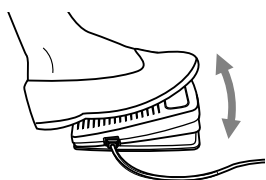

With the sewing machine turned off, insert the foot control plug into its connector on the sewing machine.

Turn on the sewing machine, and then slowly depress the foot control to start sewing. Release the foot control to stop the sewing machine.

⚠ Attention:

Consult a qualified electrician if in doubt as how to connect the machine to the power source. Unplug the power cord when the machine is not in use.

Use only foot controller type C-9000 with sewing machine model London 7 and London 8.

Sewing Table

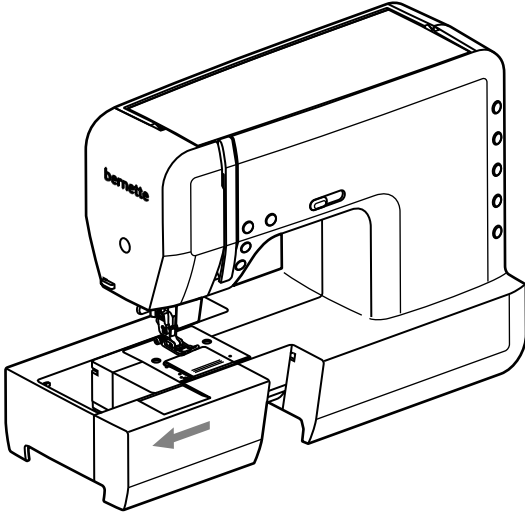

Keep the snap-in sewing table horizontal, and pull it in the direction of the arrow.

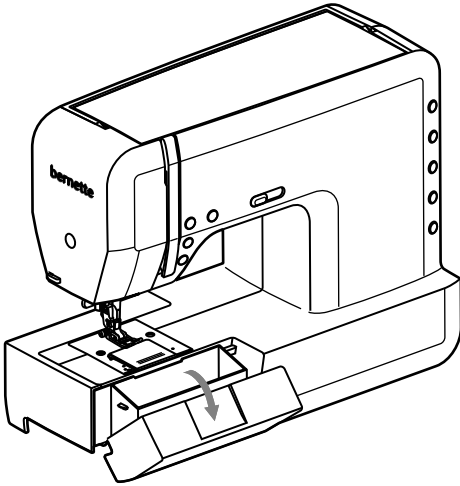

The inside of the snap-in sewing table is used as an accessory box.

To open, tilt the cover towards you.

Push-Push Top cover

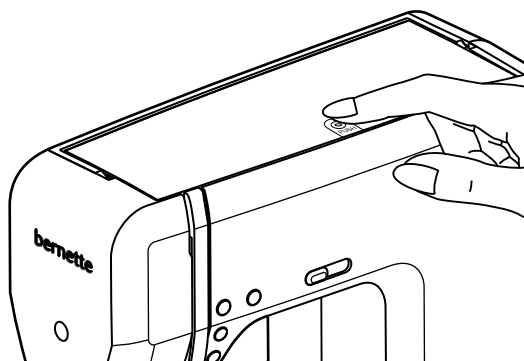

Press with your finger on the symbol "  " and the top cover jumps up.

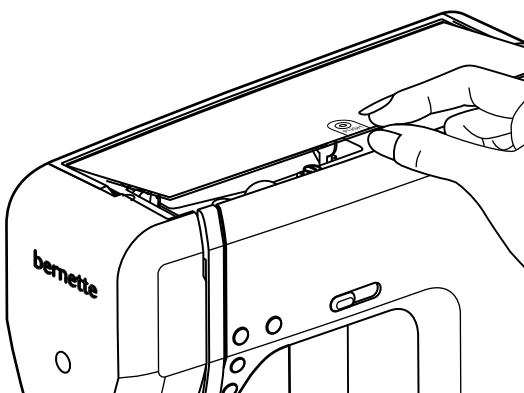

Fold up the top cover.

To close the top cover, fold down the top cover and press again on the symbol "  ".

Stitch selector wheel

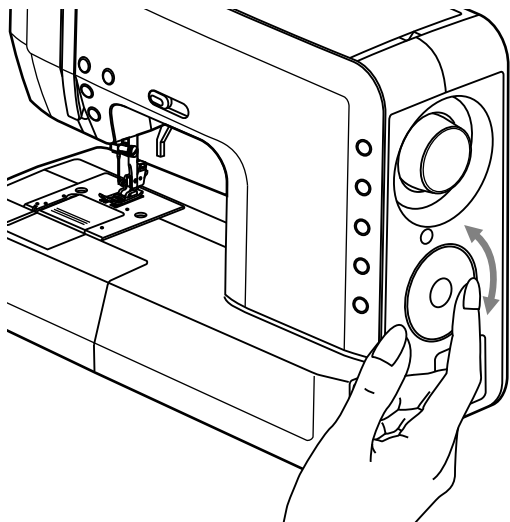

Touch with your finger at the outer rim of the stitch selector wheel and scroll forward / backward.

Winding the Bobbin

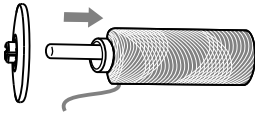
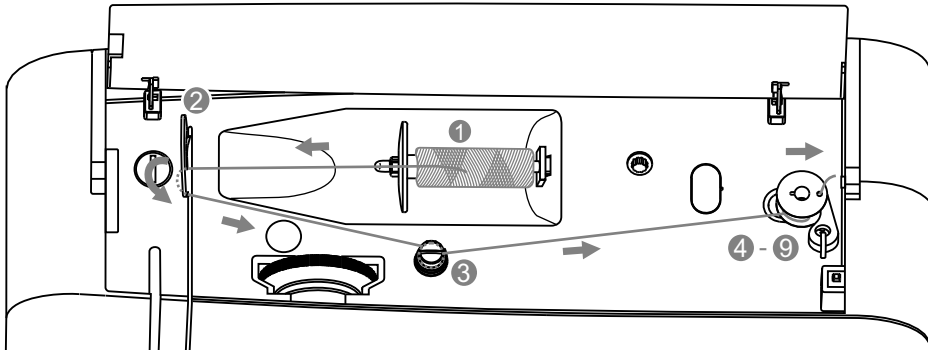

1. Place the thread and spool holder onto the spool pin.
For smaller spools of thread, place spool holder with the small side next to the spool or use the small spool holder.

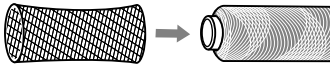

- Note:**
If using special thread which winds quickly off the spool attach a net to the spool before using and use the larger spool holder. Eventually reduce the thread tension as well.

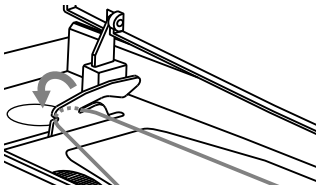

2. Snap the thread into the upper thread guide.

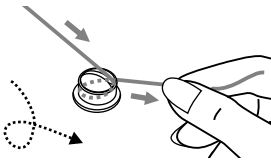

3. Wind the thread clockwise around the bobbin winder tension discs.

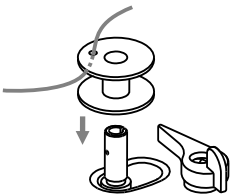

4. Place the thread end through one of the inner holes in the bobbin as illustrated and place empty bobbin on the spindle.

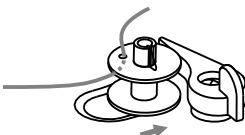

5. Push the bobbin to right.

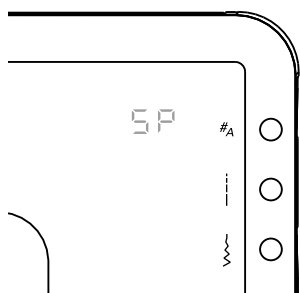

Note:

When the bobbin winder spindle is pushed to the right, the machine will display the symbol "SP"

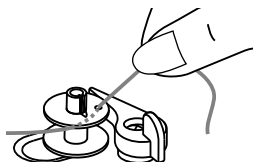

6. Hold the thread tail securely in one hand.

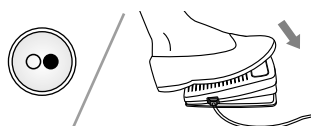

7. Press on the foot control or the Start/Stop button to start winding the bobbin.

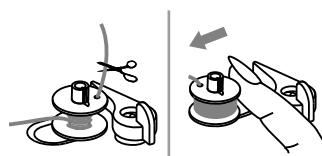

8. After the bobbin has wound a few turns stop the machine and cut the thread near the hole of the bobbin. Continue filling the bobbin until it is full.

The motor stops automatically when the bobbin is full. Stop the machine. Push the bobbin winder spindle to left.

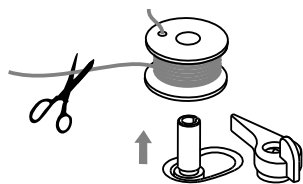

9. Cut the thread and then remove the bobbin.



Note:

When the bobbin winder spindle is placed on the right, "bobbin winding position", the machine will not sew and the handwheel will not turn. To start sewing, push the bobbin winder spindle to the left "sewing position".

Inserting the Bobbin

⚠ Attention:

- Turn power switch to "O" before threading or unthreading the machine.
- The thread take-up lever must be in the highest position when threading.
- A wrong threading in can cause damages to the machine!

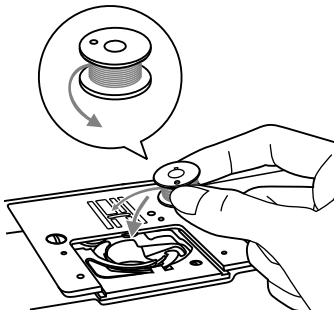

To open the bobbin cover, slide it against you.

Inserting the bobbin in the bobbin holder with the thread running counter clockwise direction.

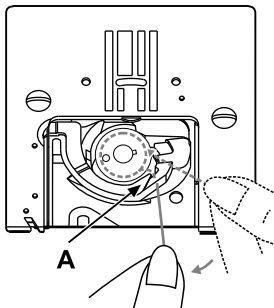

Pull the thread along the arrow marking through the slit under the finger (A) as far as the pulley (B).

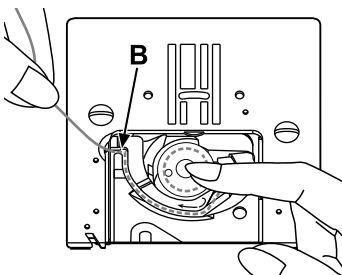

To make sure that the thread is pulled into the tension spring of the bobbin holder, press a finger slightly onto the bobbin while pulling. As a check you must feel a resistance in the thread feed.

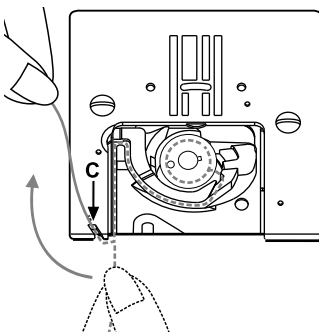

Pull the thread at the arrow markings into the stitch plate thread guide from (B) to (C).

To cut off excess thread pull thread back over the cutting off blade at point (C).

To close the bobbin cover, push it to the back.

Threading the Upper Thread

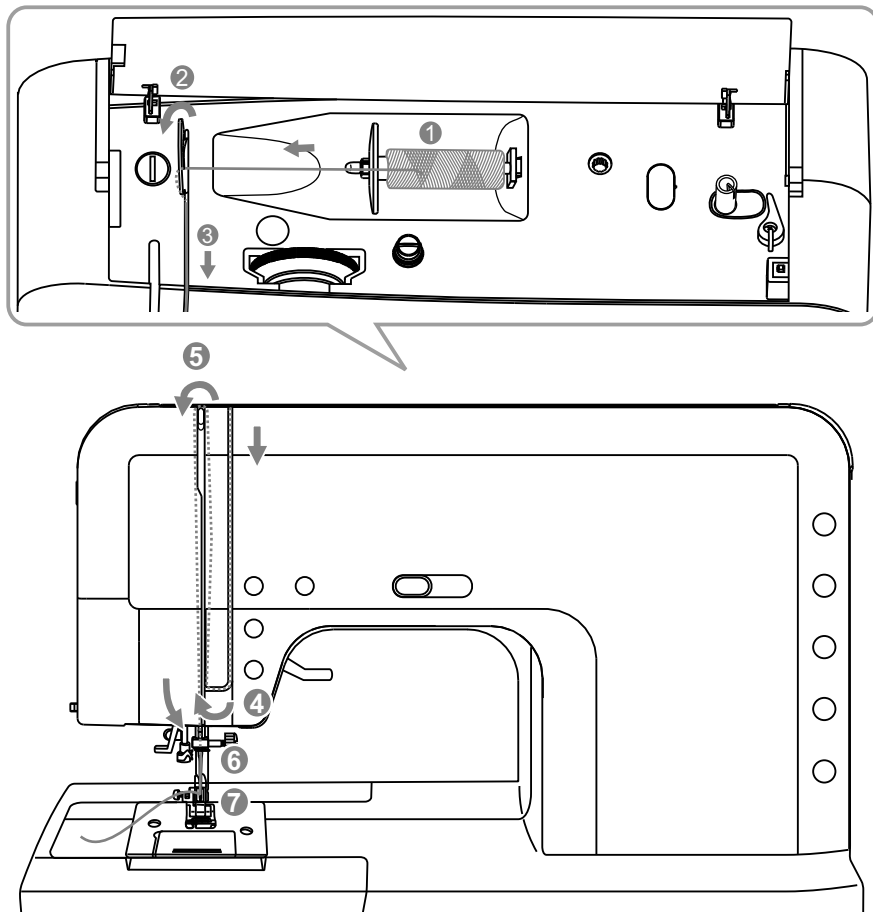

➔ Please Note:

It is important to carry out the threading correctly as by not doing so several sewing problems could result.

Start by raising the needle to its highest point, and also raise the presser foot to release the tension discs.

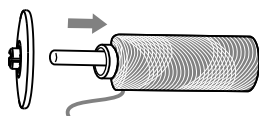

1. Place the thread and spool holder onto the spool pin.
For smaller spools of thread, place spool holder with the small side next to the spool or use the small spool holder.

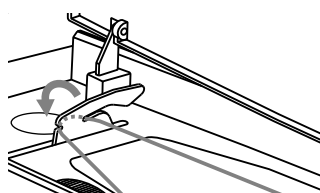

2. Snap the thread into the upper thread guide.

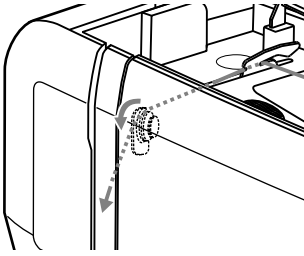

3. Pull the thread forward and down. This operation pulls the thread into the thread tension.

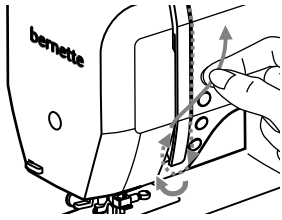

4. Then further down and around the bottom part of the take up lever cover.

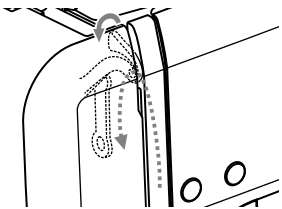

5. At the top of this movement, pass the thread from right to the left through the slotted eye of the take-up lever and then downwards again.

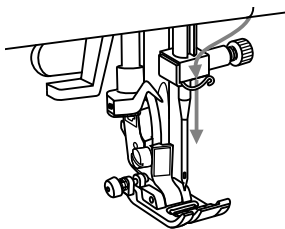

6. Guide the thread through the wire loop.

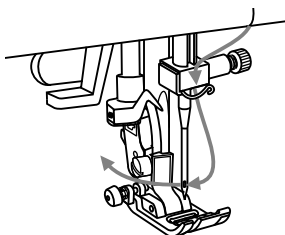

7. Pull the end of the thread through the needle from front to rear, and pull out about 10 cm of thread.
Use the face plate thread cutter to cut excess needle thread.
Use the needle threader to thread the needle (refer to next page for instruction).

Needle Threader

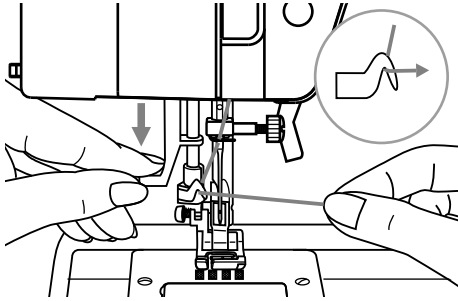

Raise the needle to its highest position and lower the presser foot.

⚠ Attention:

Turn power switch to the off position ("O").

Lower the needle threader lever slowly and draw the thread through the thread guide as illustrated and then to the right.

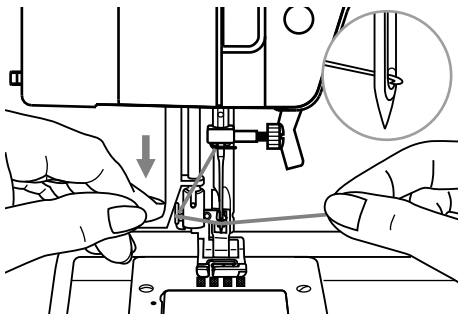

The needle threader automatically turns to the threading position and the hook pin passes through the needle eye.

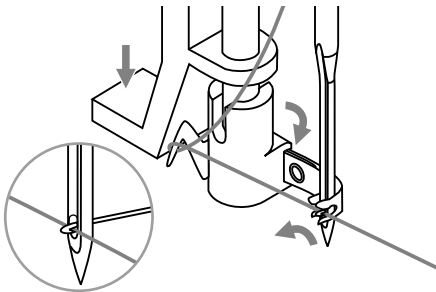

Pull the thread to the right, guiding it to the front of the needle

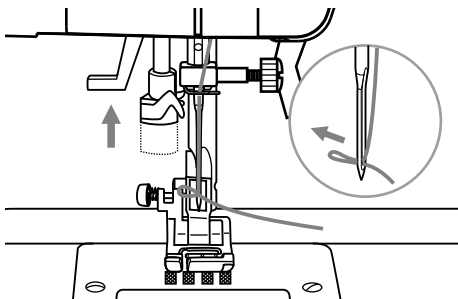

Hold the thread loosely and release the lever slowly.

The hook will turn and pass the thread through the needle eye forming a loop.

Pull the thread through the needle eye.

Replacing the Needle

⚠ Attention:

Turn power switch to off ("O") when carrying out the below operation!

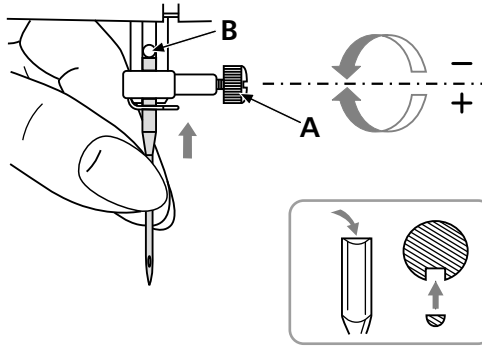

Change the needle regularly, especially if it is showing signs of wear and causing problems.

Insert the needle following the illustrated instructions.

A. Loosen the needle clamp screw and tighten again after inserting the new needle. The flat side of the shaft should be towards the back.

B. Insert the needle as far up as it will go.

Needles must be in perfect condition.

Problems can occur with:

- Bent needles
- Blunt needles
- Damaged points

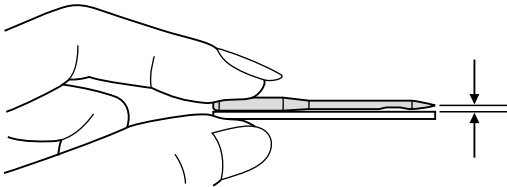

Thread Cutter

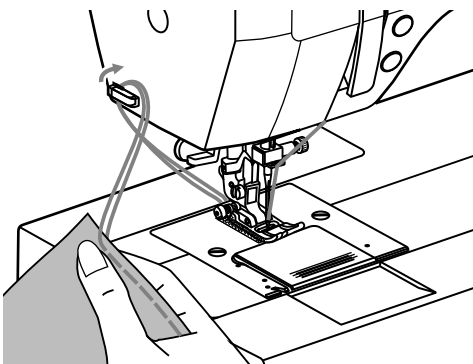

The thread cutter serves two purposes.

1. Cut the thread after threading the needle
2. Cut the thread after finishing a seam.

To cut the thread after completing your work raise the presser foot.

Remove the fabric, draw the threads to the left side of the face cover and cut using the thread cutter.

The threads are cut at the proper length to start the next seam.

Thread Tension

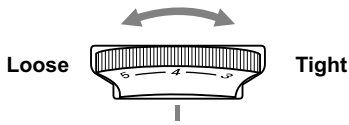

- Basic thread tension setting: "4"
- To increase the tension, turn the dial to the next number up. To reduce the tension, turn the dial to the next number down.
- Proper setting of tension is important to good sewing.
- For all decorative sewing you will always obtain a nicer stitch and less fabric puckering when the upper thread appears on the bottom side of your fabric.

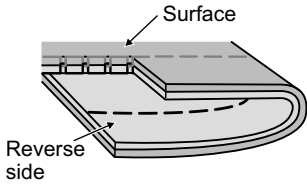

Normal thread tension for straight stitch sewing.

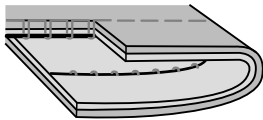
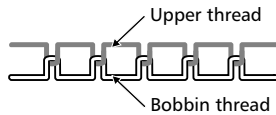

Thread tension is too loose for straight stitch sewing. Turn dial to higher number.

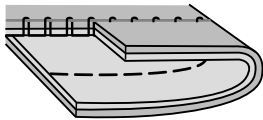

Thread tension is too tight for straight stitch sewing. Turn dial to lower number.

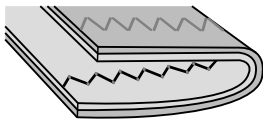

Normal thread tension for zig zag and decorative sewing.



Adjusting Presser Foot Pressure

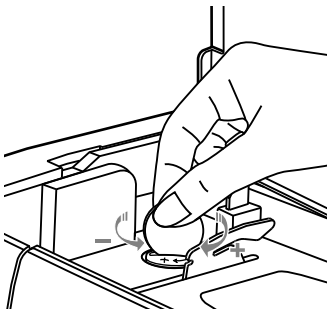

The presser foot pressure of the machine has been pre-set and requires no particular readjustment according to the type of fabric (light-or-heavy weight).

However, if you need to adjust the presser foot pressure, turn the presser adjusting screw with a coin.

For sewing very thin fabric, loosen the pressure by turning the screw counter-clockwise, and for heavy fabric, tighten by turning it clockwise.

To return to initial pressure foot setting turn the pressure adjusting screw to become flush with the face cover.

Changing the Presser Foot

⚠ Attention:

Turn power switch to off ("O") when carrying out any of the below operations!

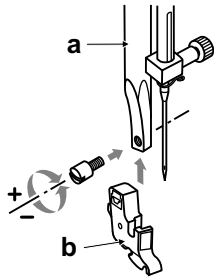

Attaching the presser foot holder

Raise the presser foot bar (a).

Attach the presser foot holder (b) as illustrated.

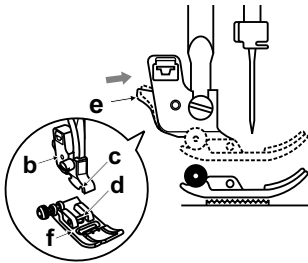

Attaching the presser foot

Lower the presser foot holder (b) until the cut-out (c) is directly above the pin (d).

Press the black lever (e).

Lower the presser foot holder (b) and the presser foot (f) will engage automatically.

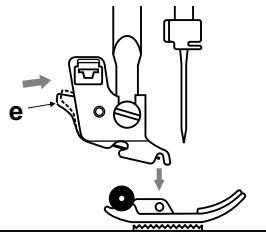

Removing the presser foot

Raise the presser foot.

Press the black lever (e) and the foot will disengage.

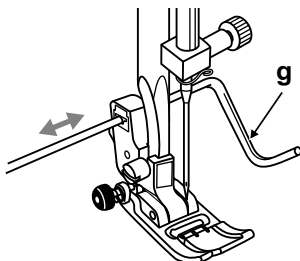

Attaching the edge/quilting guide

Attach the edge/quilting guide (g) in the slot as illustrated.

Adjust according to need for hems, pleats, etc.

Two-Step Presser Foot

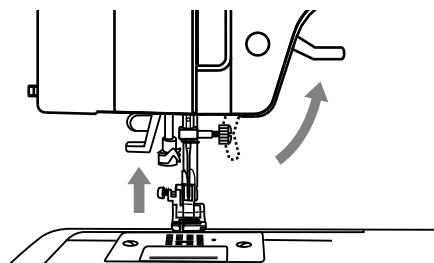

The presser foot lever raises and lowers your presser foot.

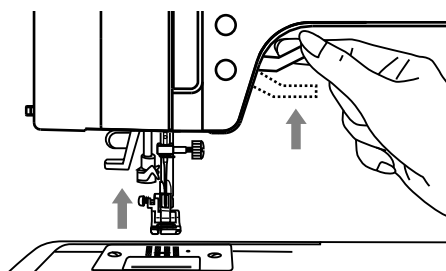

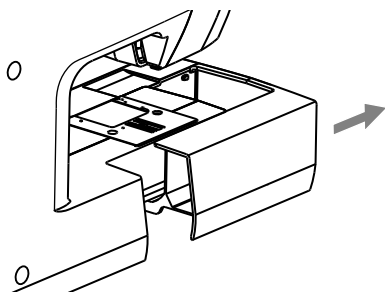

When sewing several layers of thick fabric, the presser foot can be raised to a second stage by pushing the presser foot lever further up. This allows for easy positioning of the work.

To Raise or Drop the Feed Dogs

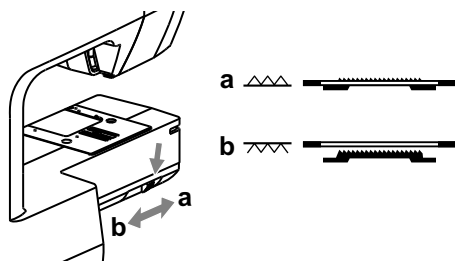

With the sewing table detached, the drop feed lever can be located on the back of the free arm.



Sliding the lever to the "  " (b) will lower the feed dog, for example during button sewing or freehand embroidery.

If you wish to continue sewing normally, slide the lever to the "  " (a) in order to raise the feed dogs.

The feed dog will not rise up if you do not turn the handwheel, even if the lever is slid to the right. Make a complete turn to raise the feed dogs.

Needle, Fabric, Thread Selection Guide

→ Important:

The thread is chosen according to use. For a perfect sewing result, thread and fabric quality play an important role. It is recommended to use quality brands.

Care must be taken when choosing needle and thread. The correct needle size depends on the selected thread and fabric. The fabric weight and type determine the thread weight, needle size and point form.

Needle size	Fabrics	Thread
9-11/65-75	Lightweight fabrics-thin cottons, voile, serge, silk, muslin, Qiana, interlocks, cotton knits, tricots, jerseys, crepes, woven polyester, shirt & blouse fabrics.	Light-duty thread in cotton, nylon or polyester.
12/80	Medium weight fabrics-cotton, satin, kettlecote, sailcloth, double knits, lightweight woollens.	Most threads sold are medium size and suitable for these fabrics and needle sizes. Use polyester threads on synthetic materials and cotton on natural woven fabrics for best results.
14/90	Medium weight fabrics-cotton duck, woolen, heavier knits, terrycloth, denims.	Always use the same thread on top and bottom.
16/100	Heavyweight fabrics-canvas, woollens, outdoor tent and quilted fabrics, denims, upholstery material (light to medium).	
18/110	Heavy woollens, overcoat fabrics, upholstery fabrics, some leathers and vinyls.	Heavy duty thread, carpet thread. (Use heavy foot pressurelarge numbers.)

NEEDLE, FABRIC SELECTION

Needles	Explanation	Type of fabric
HA x 1 15 x 1	Standard sharp needles. Sizes range thin to large. 9 (65) to 18 (110)	Natural woven fabrics-wool, cotton, silk, etc. Qiana. Not recommended for double knits.
15 x 1/ 130/ 705H	Semi-ball point needle, scarfed. 9 (65) to 18 (110)	Natural and synthetic woven fabrics, polyester blends. Knits-polyesters, interlocks, tricot, single and double knits. Can be used instead of 15x1 for sewing all fabrics.
15 x 1/ 130/ 705H (SUK)	Full ball point needle 9 (65) to 18 (110)	Sweater knits, Lycra, swimsuit fabric, elastic.
130PCL/ 705H-LR/LL	Leather needles. 12 (80) to 18 (110)	Leather, vinyl, upholstery. (Leaves smaller hole than standard large needle.)

→ Note:

- Twin needles can be purchased for utility and decorative work.
- European needles show sizes 65, 70, 80 etc. American and Japanese needles show size 9, 11, 12 etc.
- Replace needle often (approximately every other garment) and / or at first thread breakage or skipped stitches.

Presser Foot Application Chart - model London 7

Double needle is being suggested for certain stitches for more creativity

PRESSER FOOT	APPLICATION	NEEDLE	PRESSER FOOT	APPLICATION	NEEDLE
<p>All purpose foot (T)</p>	General sewing, Patchwork stitches, Decorative stitching, Smocking, Fagoting, etc.		<p>Blind hem foot (F)</p>	Blind hem stitching	
<p>Zipper foot (I)</p>	Inserting zippers		<p>Hemmer foot (K) *</p>	Narrow hemming	
<p>Button sewing foot</p>	Button sewing		<p>Cording foot (M) *</p>	Cording	
<p>Buttonhole foot (D)</p>	Buttonhole sewing		<p>Invisible Zipper foot *</p>	Inserting invisible zippers	
<p>Satin stitch foot (A)</p>	Satin stitch sewing		<p>Gathering foot *</p>	Gathering	
<p>Overcasting foot (E)</p>	Overcasting		<p>Walking foot *</p>	This foot helps to prevent uneven feeding of very difficult fabrics	
<p>1/4" Quilting foot *</p>	Quilting and patchwork sewing				
<p>Darning/Embroidery foot *</p>	Darning Free embroidery Monogramming		<p>Twin needle *</p>		

* Available as optional accessories

Presser Foot Application Chart - model London 8

Double needle is being suggested for certain stitches for more creativity

PRESSER FOOT	APPLICATION	NEEDLE	PRESSER FOOT	APPLICATION	NEEDLE
<p>All purpose foot (T)</p>	General sewing, Patchwork stitches, Decorative stitching, Smocking, Fagoting, etc.		<p>Blind hem foot (F)</p>	Blind hem stitching	
<p>Zipper foot (I)</p>	Inserting zippers		<p>Hemmer foot (K) *</p>	Narrow hemming	
<p>Button sewing foot</p>	Button sewing		<p>Cording foot (M) *</p>	Cording	
<p>Buttonhole foot (D)</p>	Buttonhole sewing		<p>Invisible Zipper foot *</p>	Inserting invisible zippers	
<p>Satin stitch foot (A)</p>	Satin stitch sewing		<p>Gathering foot *</p>	Gathering	
<p>Overcasting foot (E)</p>	Overcasting		<p>Walking foot *</p>	This foot helps to prevent uneven feeding of very difficult fabrics	
<p>1/4" Quilting foot *</p>	Quilting and patchwork sewing				
<p>Darning/Embroidery foot</p>	Darning Free embroidery Monogramming		<p>Twin needle *</p>		

* Available as optional accessories

Buttons Explanation - model London 8

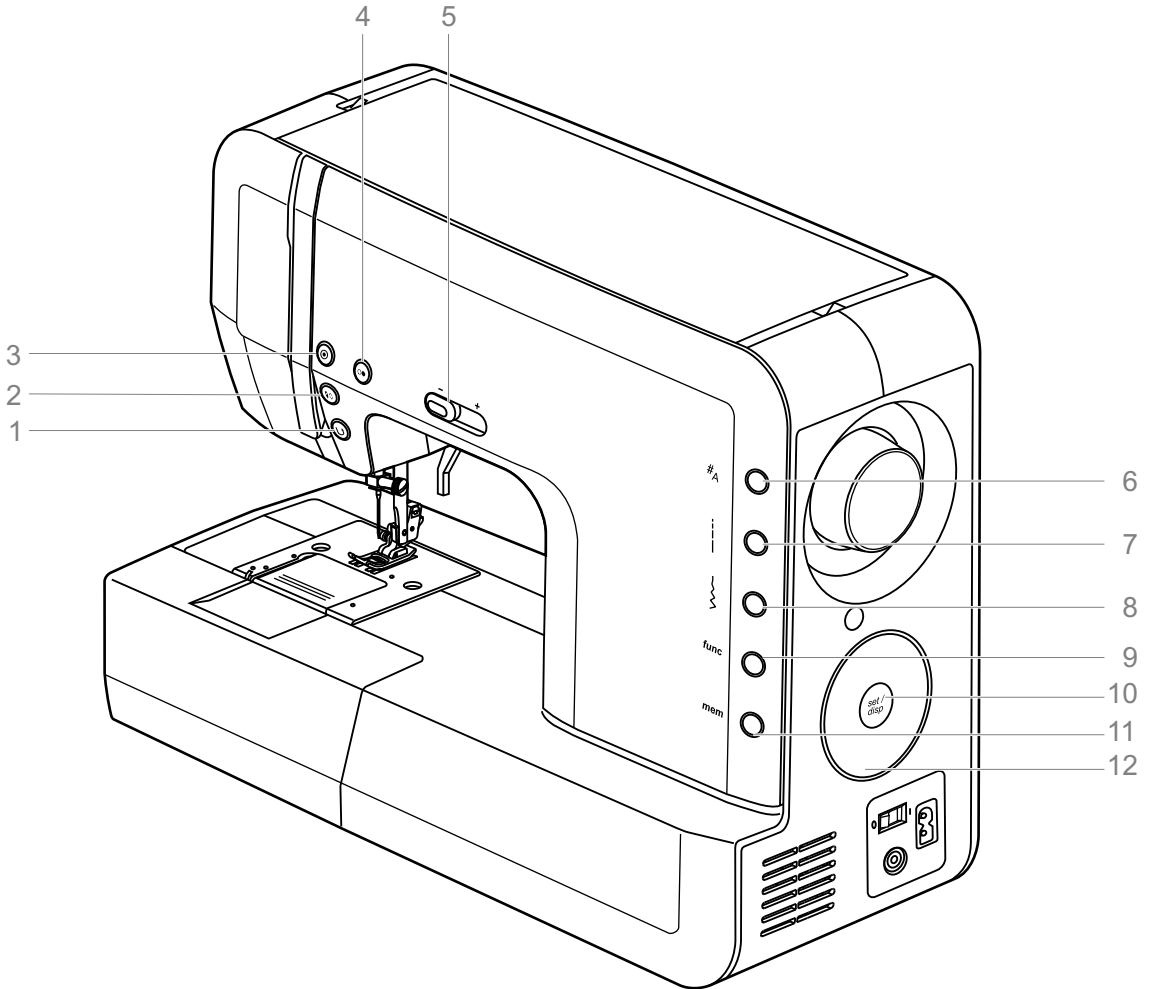

1. Reverse button
2. Needle up/ down button
3. Auto-lock button
4. Start/stop button
5. Slide speed
6. Pattern group selection button
7. Stitch length button
8. Stitch width button
9. Function button (model London 8)
10. Set/disp button
11. Memory button (model London 8)
12. Selector wheel

Information on the LED Display

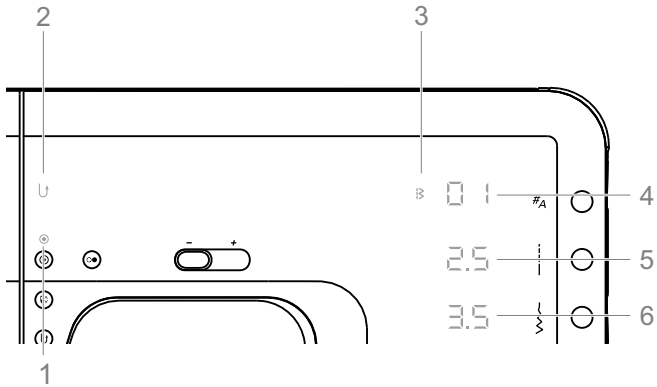

Normal mode display - model London 8

1. Auto-lock
2. Reverse
3. Pattern group
4. Stitch number
5. Stitch length
6. Stitch width
7. Needle stop down
8. Auto-stop on pattern end
9. Machine running
10. Pattern Mirrored function
11. Twin needle function
12. Alphabets group

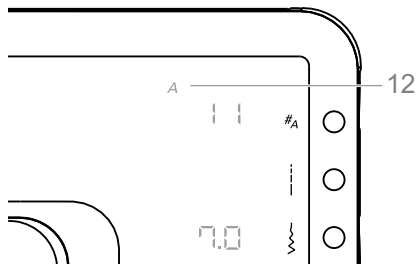
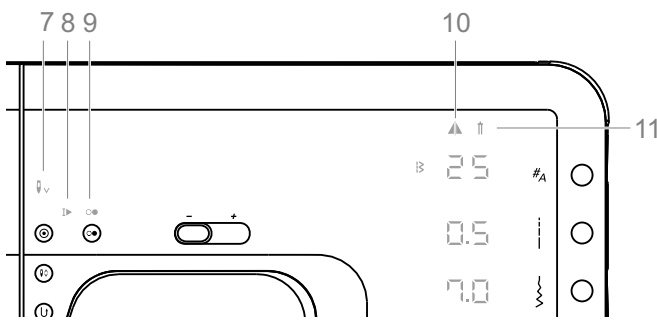

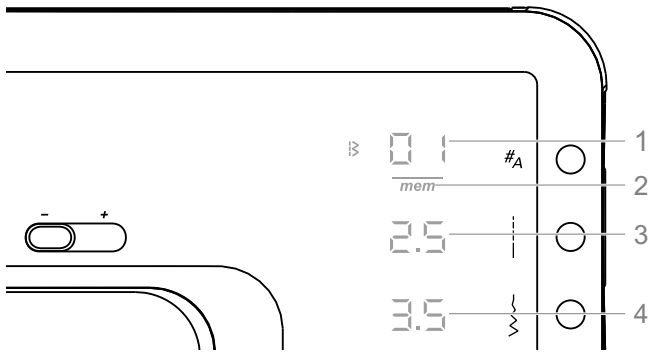

Memory mode display - model London 8

1. Stitch number
2. Memory mode active
3. Stitch length
4. Stitch width
5. Memory position display
6. Memory position
7. Memory insert function
8. Memory delete/delete ALL function

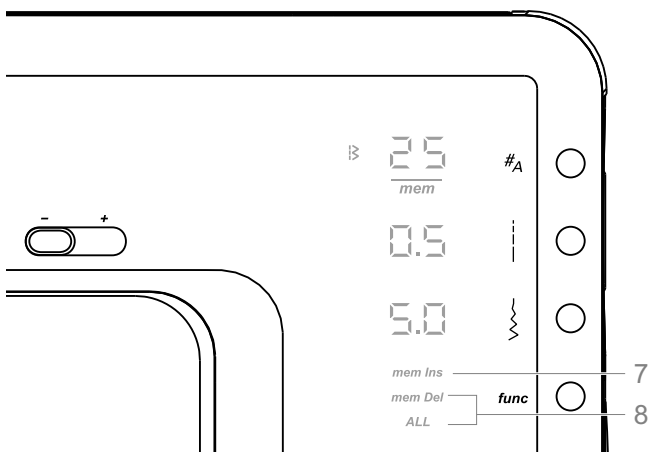
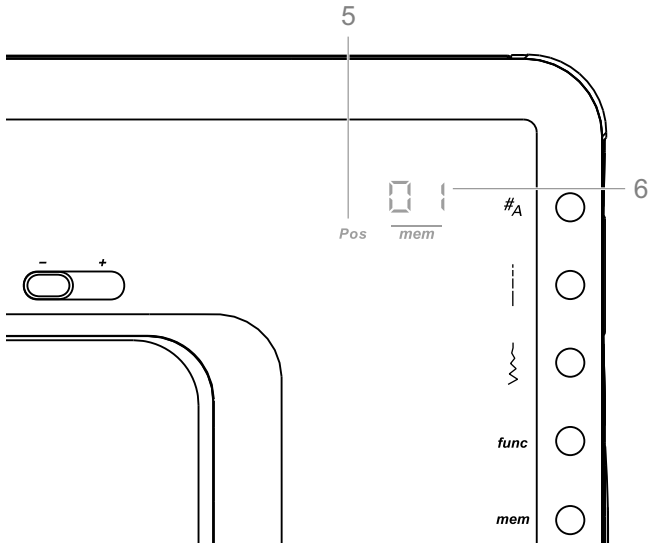

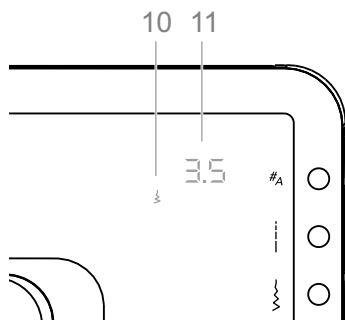
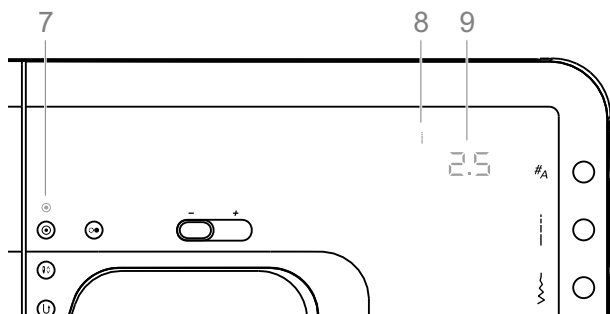
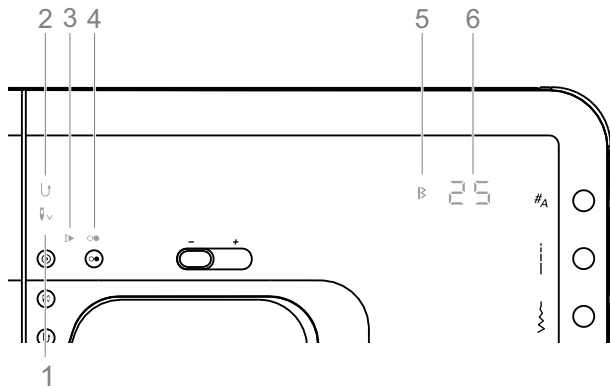

Normal mode display - model London 7

1. Needle stop down
2. Reverse
3. Auto-stop on pattern end
4. Machine running
5. Pattern group
6. Stitch number
7. Auto-lock
8. Stitch length mode
9. Stitch length
10. Stitch width mode
11. Stitch width

Note:

- To display stitch length or stitch width, press the corresponding button.
- The symbol on the left of the display indicates which value is shown in the display.

Function Buttons

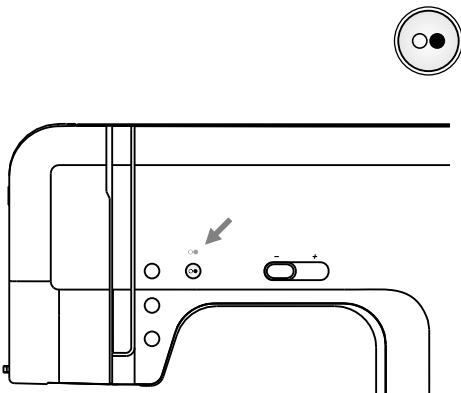

Start/stop button

Press the start /stop button to start the machine. Press again to stop it. The machine will rotate slowly at start of sewing. This way you may operate the machine without foot control.

When the machine is sewing or winding the bobbin, the start /stop symbol will display.

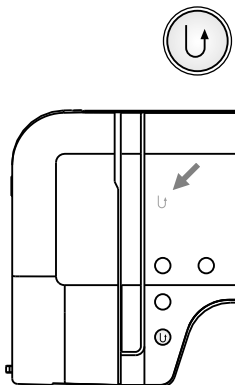

Reverse button

Reverse is pressed to sew in reverse. The machine will display the symbol "↶" indicates reverse sewing.

Only the pattern 01-05 and 24 can be sewn in reverse.

The machine will permanently sew in reverse. Press the button again to sew forward.

If you press and release the button before starting to sew, the machine will permanently sew in reverse and press the button again to sew forward.

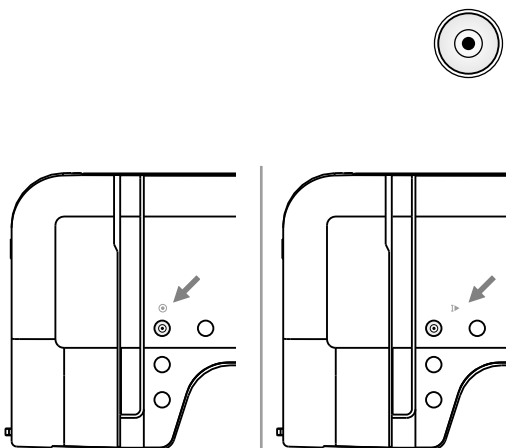

Auto-lock button and single pattern

When the patterns 01-05 and 24 are selected, the machine will immediately sew 3 locking stitches when the auto-lock button is pressed, then automatically stop.

The machine will display the symbol "●" until the machine is stopped.

Except for the pattern 01-05, 10, 24 and 50-60, press the auto-lock button, the machine will sew 3 locking stitches at the end of the current pattern and automatically stop.

The machine will display the symbol "▶" until the machine is stopped. The function will be cancelled if you press the button once again or select another pattern.

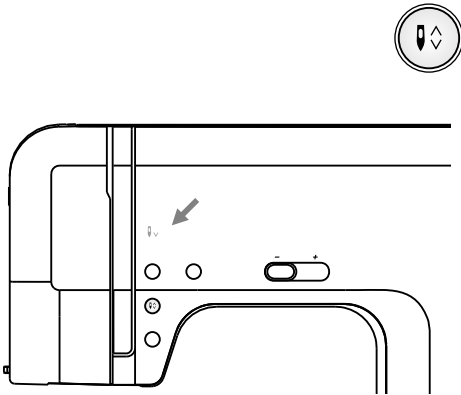

Needle up/down button

By pressing the needle up/down button the needle will make half a stitch. Depending on the actual needle position it will stop in the opposite position, either at the highest or the lowest position. At the same time the needle stop position after sewing is permanently set.

When the needle stops down, the needle down symbol "↓" will display.

➔ Please Note

During sewing, press the needle up/down button, the machine will stop automatically.

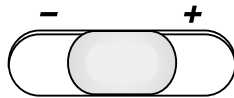

Slide speed

By adjusting the position of the slide speed the top speed during sewing may be limited. The position of the slider defines the sewing speed at full stroke of the foot controller.

For slower speed: Slide toward (-)

For higher speed: Slide toward (+)

When the machine is run with the start/stop button the position of the slide speed defines the actual sewing speed.



Set/disp button

In the Normal Mode press this button to memorize stitch pattern number and save the stitch length and width value.

In the function mode press this button to toggle selected function and memorize it.

In the Memory Mode press this button to memorize a pattern or to switch display from stitch number to memory position and back.

General Operating Principles

Whatever value or setting is blinking can be adjusted by the Selector Wheel.

- **Select function** by pressing a button once
- **Safe adjustments** by pressing Set or the button near the flashing value. Alternatively in most functions pressing start/stop or the foot controller will save the changes as well
- For **special functions** (Alphabet, switch from Memory Enter Mode to Memory Review/Edit Mode, Delete ALL) there are special keystroke combinations
- **Error Beep** = 3 short beeps

Normal Mode: Select stitch and sew. There are two Pattern groups available, the Pattern group and Alphabet group (only model London 8).

Memory Mode: Program a sequence of stitches and sew mem indicator " *mem* " on = memory mode active. (For detailed Memory Mode descriptions see from page 65)

Normal Mode - model London 8

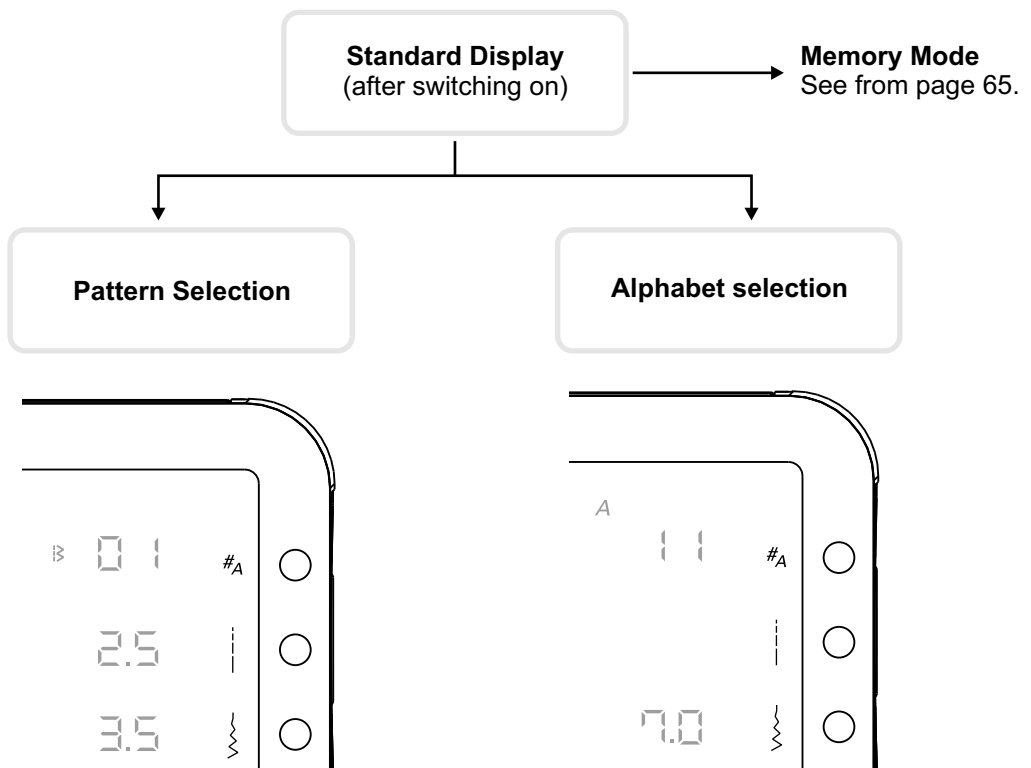

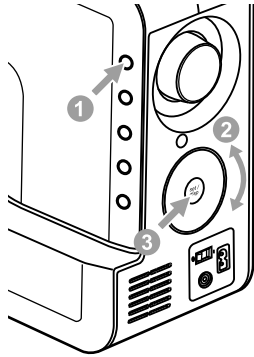

Setting a pattern

1. Press the pattern group selection button once to enter a stitch pattern selection.
2. Use selector wheel to select desired stitch.
3. Press set/dispatch button to memorize it.

Note:

Other parameters, i.e. stitch length and stitch width can be changed before or after memorizing the pattern by pressing the corresponding button and following point 2 and 3.

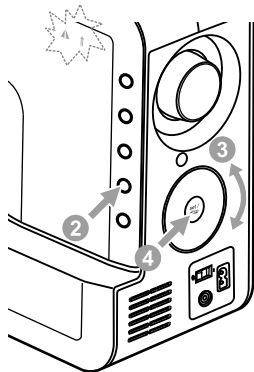

Setting an additional function

1. Select the pattern.
2. Press the function button to open the function program.
3. Use selector wheel to scroll to Twin Needle or to Mirror function.
4. Press set/dispatch button to toggle chosen function.

Note:

Initially both symbols are flashing. When starting to scroll only the selected function is flashing.



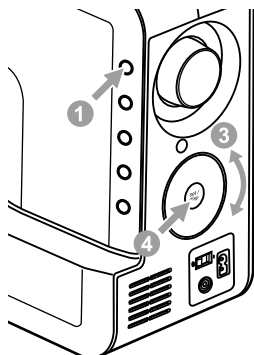



























See Page 62 / 63 for details.



Setting Alphabets

1. Double click the pattern group selection button to enter Alphabet selection.
2. Press pattern group selection button once again to start the stitch number flashing.
3. Use selector wheel to select desired stitch.
4. Press set/dispatch button to memorize it.

Stitches

Stitch Pattern		Width (mm)		Length (mm)		Presser Foot	Functions				
		Auto	Manual	Auto	Manual		Reverse	Auto-lock	Mirror/ Presser foot (For London 8)	Twin needle (For London 8)	Memory (For London 8)
Straight Stitch	01 	3.5	0.0-7.0	2.5	0.0-4.5	T	*	*		*	*
	02 	0.0	0.0-7.0	2.5	0.0-4.5	T	*	*		*	*
Tripple Straight	03 	3.5	0.0-7.0	2.5	1.0-3.0	T	*	*		*	*
Zig-Zag	04 	5.0	0.0-7.0	2.0	0.3-4.5	T	*	*		*	*
3 Step Zig-Zag	05 	5.0	2.0-7.0	1.0	0.3-4.5	T	*	*		*	*
Double Overlock	06 	5.0	3.5-7.0	2.5	1.0-3.0	E		*	*/T	*	*
Blind Hem	07 	3.5	2.5-7.0	1.0	0.5-4.5	F		*	*/T	*	*
Overlock	08 	3.5	3.5-7.0	1.0	0.5-4.5	E		*	*/T	*	*
Stretch stitich	09 	2.0	1.0-6.0	2.5	1.0-3.0	T		*	*	*	*
1 step BH	10 	5.0	2.5-7.0	0.5	0.3-1.0	D					
Tripple Zig-Zag	11 	5.0	2.5-7.0	2.5	1.0-3.0	T		*		*	*
Stretch Overlock	12 	5.0	3.5-7.0	2.5	1.0-3.0	E		*	*/T	*	*
Honeycomb	13 	7.0	2.5-7.0	2.5	1.0-3.0	A		*		*	*
Universal	14 	5.0	2.5-7.0	2.0	1.0-3.0	T		*		*	*
Bridging Stitich	15 	6.0	2.5-7.0	1.5	1.0-4.5	T		*		*	*
Stretch Blindhem	16 	3.5	2.5-7.0	1.5	0.5-4.5	F		*	*/T	*	*
Universal	17 	5.0	2.5-7.0	2.0	1.0-4.5	T		*		*	*
Superstretch (Comb Stitich)	18 	4.0	2.5-7.0	2.0	1.0-3.0	T		*	*	*	*
Single Overlock	19 	4.0	2.5-7.0	1.0	1.0-3.0	T		*	*	*	*
Fagoting	20 	5.0	2.5-7.0	2.5	1.0-3.0	T		*		*	*
Standard Overlock	21 	5.0	3.5-7.0	2.5	1.0-3.0	E		*	*/T	*	*
Blanket (Quilting Applique)	22 	3.5	2.5-7.0	2.5	1.5-3.0	T		*	*	*	*
Feather	23 	5.0	2.5-7.0	2.5	1.0-3.0	A		*		*	*
Hand Look Quilting	24 	3.5	0.0-7.0	2.5	1.0-3.0	T	*	*		*	*
Scallop	25 	7.0	2.5-7.0	0.5	0.3-1.0	A		*	*	*	*
Trapeze	26 	7.0	2.5-7.0	0.5	0.3-1.0	A		*		*	*
Cross Stitich	27 	6.0	3.0-7.0	1.0	1.0-3.0	A		*	*	*	*
Squares	28 	7.0	2.5-7.0	0.5	0.3-1.0	A		*		*	*
Satin Stitich	29 	7.0	2.5-7.0	0.5	0.3-1.0	A		*	*	*	*
	30 	7.0	2.5-7.0	0.5	0.3-1.0	A		*	*	*	*

Please Note:

The portion marked in **gray** colored on the chart below shows the one unit of each pattern.

* : Adjustments can be made.

Stitch Pattern		Width (mm)		Length (mm)		Presser Foot	Functions				
		Auto	Manual	Auto	Manual		Reverse	Auto-lock	Mirror/ Presser foot (For London 8)	Twin needle (For London 8)	Memory (For London 8)
Satin Stitch	31	7.0	2.5-7.0	0.5	0.3-1.0	A		*	*	*	*
	32	7.0	2.5-7.0	0.5	0.3-1.0	A		*	*	*	*
Decorative Satin Stitch	33	7.0	2.5-7.0	0.5	0.3-1.0	A		*	*	*	*
	34	7.0	4.0-7.0	0.5	0.3-1.0	A		*		*	*
	35	7.0	4.0-7.0	0.5	0.3-1.0	A		*	*	*	*
	36	7.0	4.0-7.0	0.5	0.3-1.0	A		*		*	*
Quilting Stitch (for stippling)	37	6.0	4.5-7.0	1.0	1.0-3.0	A		*		*	*
Decorative Stitch	38	5.0	3.0-7.0	2.5	1.5-4.5	A		*		*	*
Cross Stitch	39	6.0	5.0-7.0	1.0	1.0-3.0	A		*		*	*
	40	6.0	5.0-7.0	1.0	1.0-3.0	A		*	*	*	*
Decorative Stitch	41	7.0	3.0-7.0	2.0	1.0-3.0	T		*		*	*
	42	7.0	4.0-7.0	2.5	1.5-3.0	A		*		*	*
	43	7.0	5.0-7.0	2.0	2.0-3.0	A		*		*	*
	44	7.0	4.0-7.0	3.0	2.5-4.5	A		*		*	*
Satin Stitch	45	7.0	2.5-7.0	0.5	0.3-1.0	A		*	*	*	*
	46	7.0	2.5-7.0	0.5	0.3-1.0	A		*	*	*	*
Decorative Stitch	47	5.0	2.5-7.0	2.5	1.5-3.0	T		*	*	*	*
	48	7.0	3.5-7.0	2.0	1.5-3.0	T		*	*	*	*
	49	7.0	3.0-7.0	2.0	1.5-3.0	A		*	*	*	*
Darning Stitch	50	7.0	3.5-7.0	2.0	1.0-2.0	D					
	51	7.0	3.5-7.0	2.0	1.0-2.0	D					
1 step BH	52	5.5	3.0-7.0	0.5	0.3-1.0	D					
	53	5.0	2.5-5.5	0.5	0.3-1.0	D					
	54	6.0	3.0-7.0	0.5	0.3-1.0	D					
	55	5.0	2.5-5.5	0.5	0.3-1.0	D					
	56	5.0	2.5-5.5	0.5	0.3-1.0	D					
	57	7.0	5.5-7.0	0.5	0.3-1.0	D					
	58	7.0	5.5-7.0	0.5	0.3-1.0	D					
	59	6.0	3.0-7.0	1.5	1.0-3.0	D					
Eyelet Stitch	60	7.0	5.0,6.0,7.0	-	-	A					

* : Adjustments can be made.

Please Note:

The portion marked in **gray** colored on the chart below shows the one unit of each pattern.

Alphabets - model London 8

01 02 03 04 05 06 07 08 09 10
1 2 3 4 5 6 7 8 9 0

11 12 13 14 15 16 17 18 19 20 21 22 23 24 25 26 27 28 29 30 31 32 33 34 35 36
A B C D E F G H I J K L M N O P Q R S T U V W X Y Z

37 38 39 40 41 42 43 44 45 46 47 48 49 50 51 52 53 54 55 56 57 58 59 60 61 62
a b c d e f g h i j k l m n o p q r s t u v w x y z

63 64 65 66 67 68 69 70 71 72 73 74 75 76 77 78 79 80 81 82 83 84 85 86 87 88
Ă Ā Æ Ñ Ö Ø Ç Ü ä ã å æ ë è é ê ñ ö õ ø ì ç ü ù ß &

89 90 91 92 93 94 95
? ! _ ' , . -

➔ Please Note:

- In normal mode all letters are sewn in the maximum height of 7mm. The user must line up the letters if a sequence of letters is sewn.

E I J a b g h i j p y Å Æ è ø Ç ü 

- If a sequence of letters is stored in memory, the machine will sew capital letters with a reduced height of 5.5mm. This way all letters line up automatically.

E I J a b g h i j p q y Å Æ è ø Ç ü 

- If only the capital letters are stored in memory, the machine will sew in the maximum height of 7mm.

A B C D E F G H I J K L M N 

Useful Skills

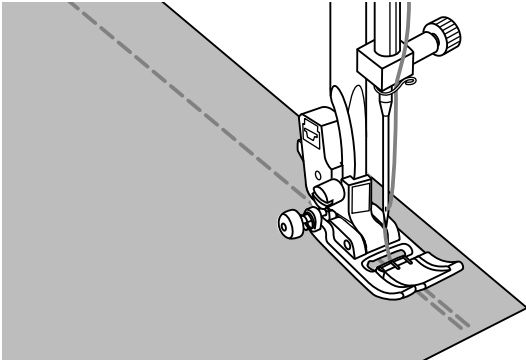

Reverse

Reverse stitching is used to secure the threads at the beginning and at the end of a seam.

Press the reverse button and sew 4-5 stitches.

The machine will sew forward when the button is released.

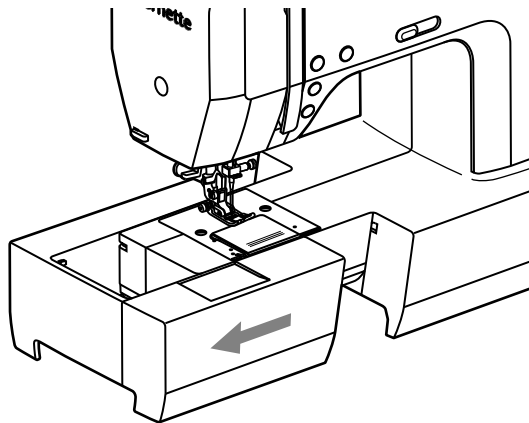

Free arm

Free-arm sewing is convenient for sewing tubular areas such as pant hems and cuffs.

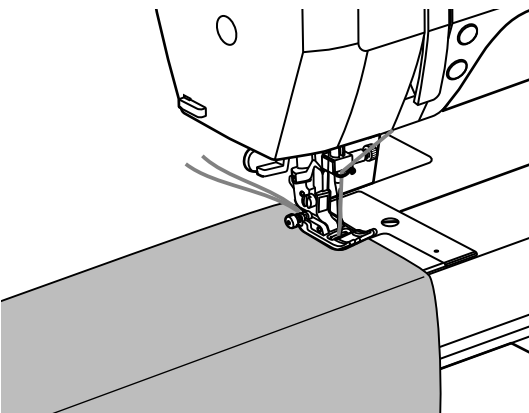

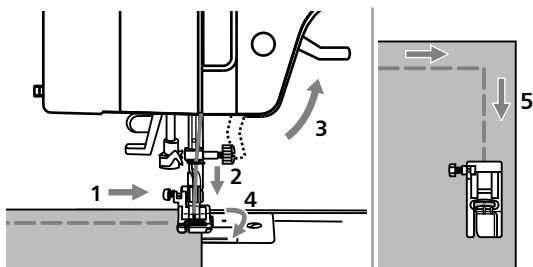

Sewing corners

1. Stop the sewing machine when you reach a corner.
2. Lower the needle into the fabric manually or by pressing the needle up/ down button once.
3. Raise the presser foot.
4. Use the needle as a pivot and turn the fabric.
5. Lower the presser foot and resume sewing.

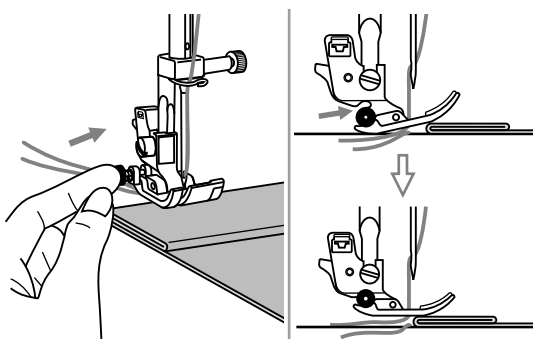

Sewing on the heavy fabric

The black button on the left side of the presser foot will lock the presser foot in a horizontal position if you push it in before lowering the presser foot. This ensures even feeding at the beginning of a seam and helps when sewing multiple layers of fabric such as sewing over seams when hemming jeans.

When you reach the point of an increased thickness, lower the needle and raise the presser foot. Press the toe of the foot and push in the black button, then lower the foot and continue sewing.

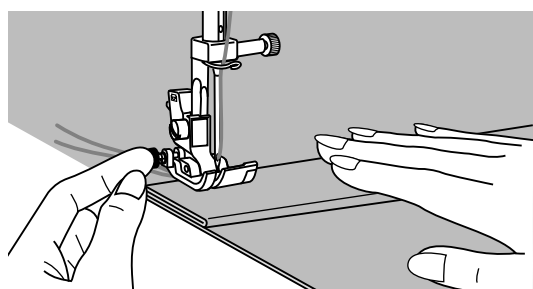

The black button releases automatically after sewing few stitches.

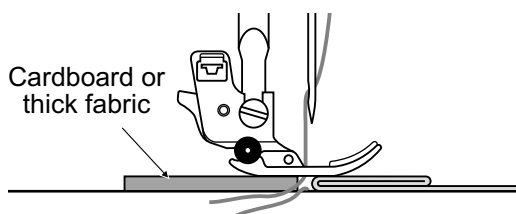

You also can place another piece of fabric with the same thickness at the back of the seam. Or support the presser foot while feeding by hand and sewing toward the folded side.

Straight Stitches and Needle Position

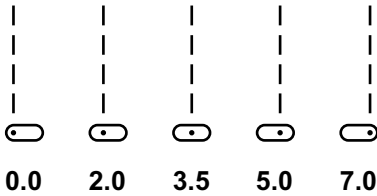
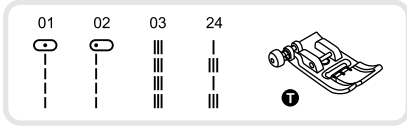

Changing the needle position

These settings apply only to pattern 01-03, 24. The pre-set position is "3.5", center position. Press the stitch width button to enter stitch width adjustment mode. When you turn the selector wheel counter clockwise, the needle position will move to the left. When you turn the selector wheel clockwise, the needle position will move to the right.

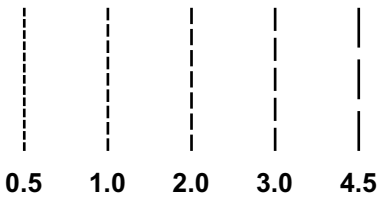

Changing the stitch length

Press the stitch length button to enter stitch length adjustment mode. To shorten the stitch length, turn the selector wheel counter clockwise. For a longer stitch length, turn the selector wheel clockwise. Generally speaking, the thicker the fabric, thread and needle, the longer the stitch should be.

Zigzag Stitches

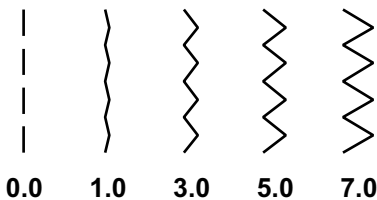
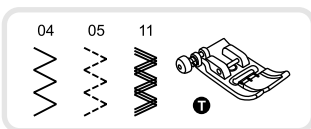

Adjusting the stitch width

The maximum zigzag stitch width for zigzag stitching is "7.0"; however, the width can be reduced on any patterns. Press the stitch width button to enter stitch width adjustment mode, the stitch width can be adjusted between "0.0-7.0 mm".

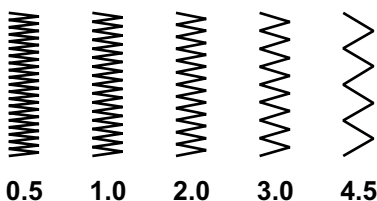

Adjusting the stitch length

The density of zigzag stitches increase as the setting of stitch length approaches "0.3". Neat zigzag stitches are usually achieved at "1.0-2.5". Closed up zigzag stitches (close together) are referred to as a satin stitch.

Stretch Stitch

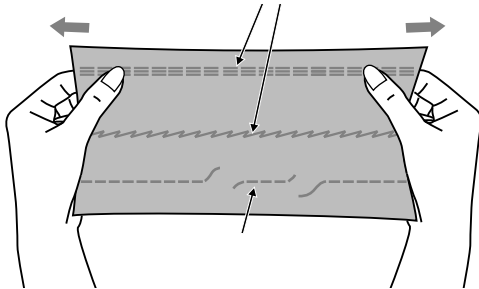
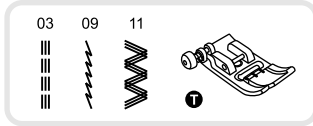

It assures you of a stitch that is strong and flexible and will give with the fabric without breaking. Good for easy to ravel and knit fabrics. It is good for joining durable fabric such as denims.

These stitches can also be used as a decorative top stitch.

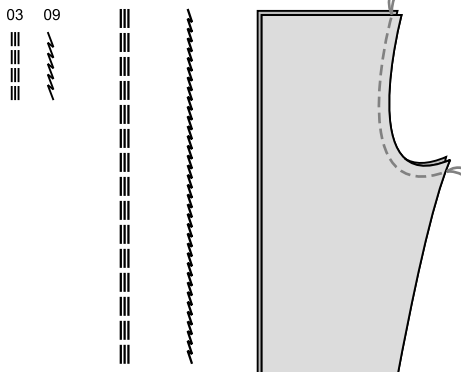

Straight stretch stitch is used to add triple reinforcement to stretch and hardwearing seams.

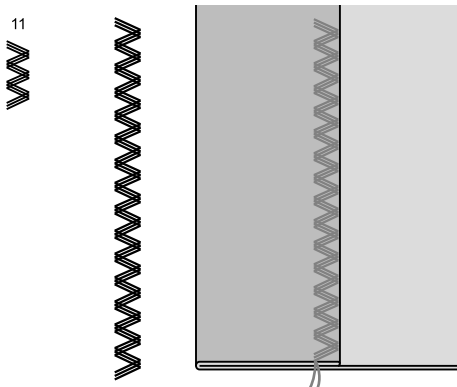

Triple zigzag stretch stitch is suitable for firm fabrics like denim, poplin, duck, etc.

Overcasting Stitches

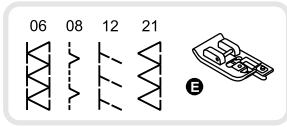

3.5~7.0	2.0~3.0

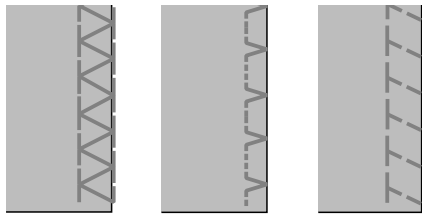
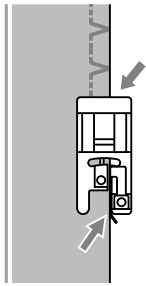
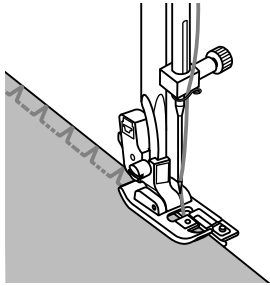

Using the overcasting foot

Change the presser foot to the overcasting foot (E).

Sew the fabric with the fabric edge against the guide of the overcasting foot.

⚠ Attention:

The overcasting foot should be used to sew with patterns 06, 08, 12 and 21 only and do not set the stitch width narrower than "3.5". It is possible that needle could hit the presser foot and break when sewing other patterns and width.

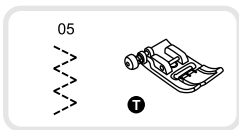

2.5~4.5	2.0~3.0

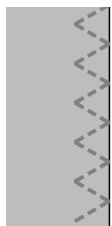
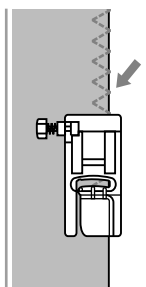
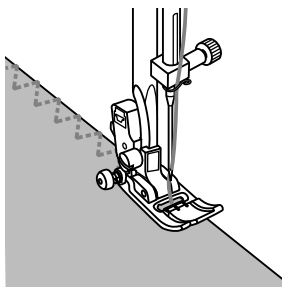

Using the all purpose foot

Change the presser foot to the all purpose foot (T).

Sewing the overcasting along the edge of the fabric so that the needle drops over the edge of the fabric on the right side.

Blind Hem

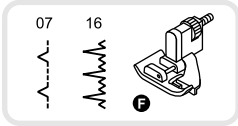

2.5~4.0	1.0~2.0

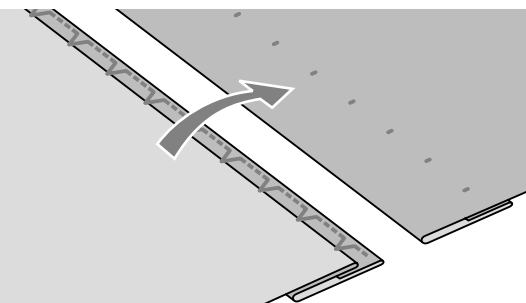
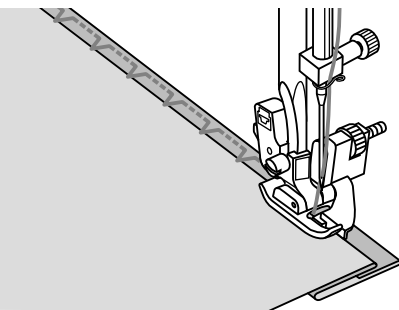
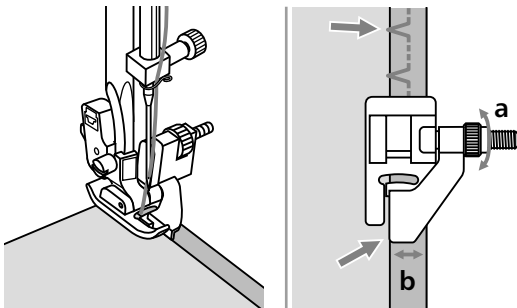
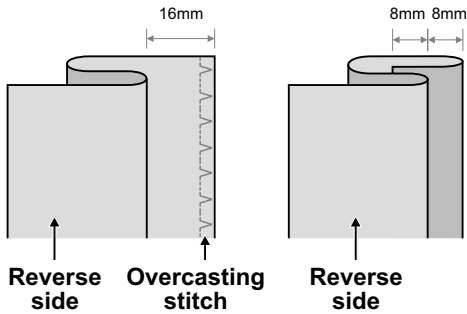

07: Blind hem/lingerie for firm fabrics

16: Blind hem for stretch fabrics

Fold the fabric as illustrated with the reverse side uppermost.

First carry out an overcasting stitch as shown in left picture.

➔ Please Note:

It takes practice to sew blind hem. Always make a sewing test first.

Place the fabric under the foot. Turn the handwheel forwards by hand until the needle swings fully to the left. It should just pierce the fold of the fabric. If it does not, adjust the stitch width accordingly.

Adjust the guide (b) by turning the knob (a) so that the guide just rests against the fold.

Sew slowly, guiding the fabric carefully along the edge of the guide.

Turn over the fabric.

Button Sewing

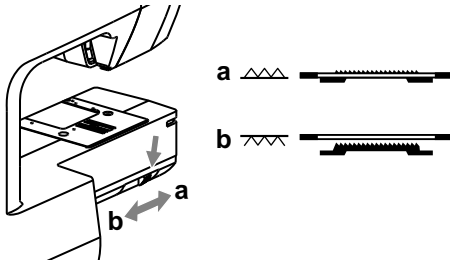

Change the presser foot to the button sewing foot.

Move the drop feed control to "  " to lower the feed dogs.

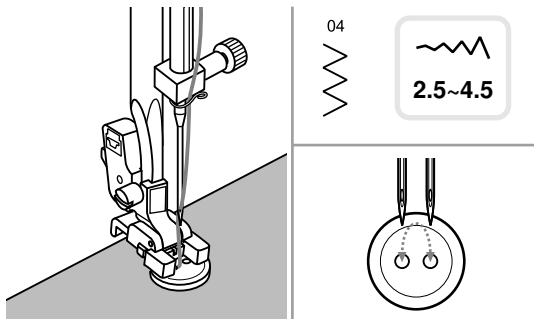

Position the work under the foot. Place the button in the desired position, lower the foot.

Select zig zag pattern. Adjust the stitch width to "2.5-4.5" according to the distance between the two holes of the button.

Turn the handwheel to check that the needle goes cleanly into the left and right holes of the button.

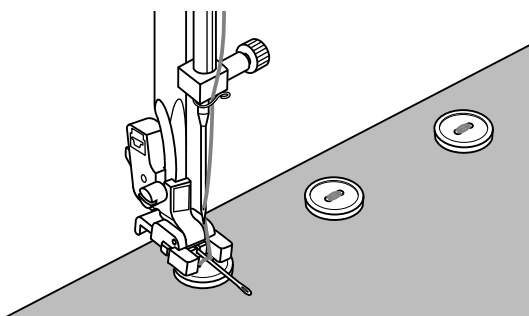

Before sewing, press the Auto-lock button to sew reinforcement stitches automatically at the beginning and at the end of the stitch.

If a shank is required, place a darning needle on top of the button and sew.

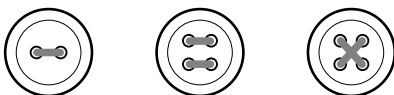

For buttons with 4 holes, sew through the front two holes first, push work forward and then sew through the back two holes.

Buttonhole Stitching

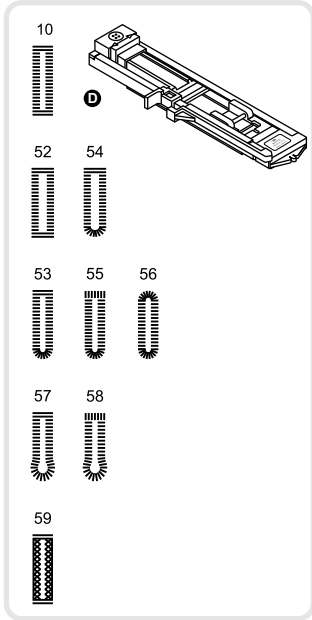

2.5~7.0	0.3~1.0

3.0~7.0	0.3~1.0

2.5~5.5	0.3~1.0

3.0~7.0	0.3~1.0

3.0~7.0	1.0~2.0

- 10: For thin or medium fabrics
- 52: For horizontal holes on blouses or shirts made from thin or medium fabrics
- 53: For thin or medium fabrics
- 54: For horizontal holes on blouses or shirts made from thin or medium fabrics
- 55: For horizontal buttonholes on thick fabrics
- 56: For thin or medium fabric
- 57: For suits or overcoats
- 58: For thick coats
- 59: For jeans or stretch fabrics with a coarse weave

Please Note:

Before sewing a buttonhole on your project, practice on a scrap piece of the same type of fabrics.

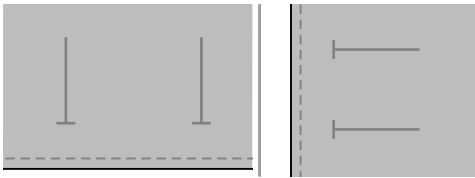

Mark the positions of the buttonhole on the fabric. The maximum buttonhole length is 3cm (1 3/16 inch). (Total of diameter + thickness of button.)

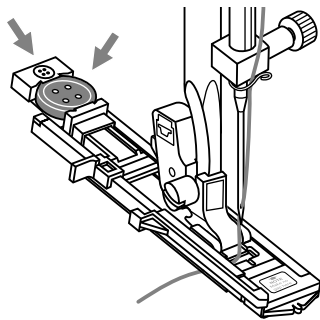

Attach the buttonhole foot, then pull out the button holder plate and insert the button. The size of the buttonhole is determined by the button inserted in the button plate. The thread should be passed through the hole in the presser foot, then be placed under the foot.

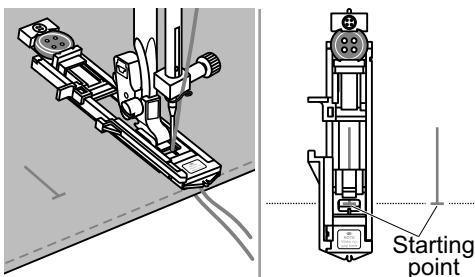

Select the buttonhole stitch. Adjust the stitch width and the stitch length to the desired width and density.

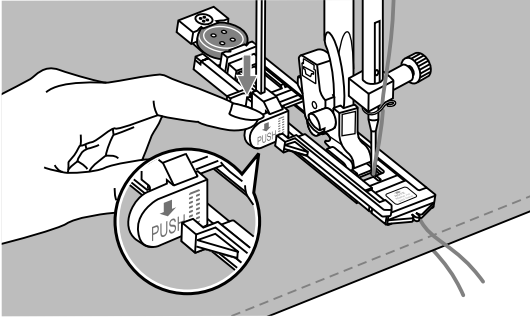

Position the fabric under the presser foot so that the centerline's mark is aligning with the center of the buttonhole foot.
Lower the buttonhole lever.

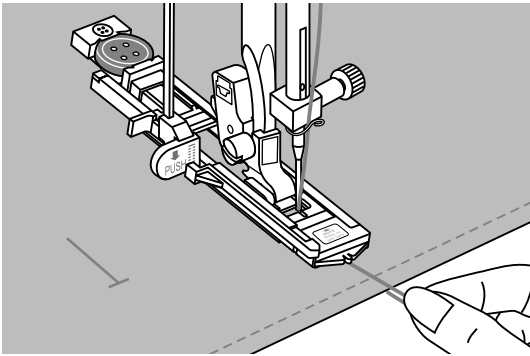

While lightly holding the end of upper thread and start sewing.

Please Note:

Gently feed the fabric by hand.
Before stopping, the machine will automatically sew a reinforcement stitch after the buttonhole is sewn.

* Buttonholes are sewn from the front of the presser foot to the back, as shown.

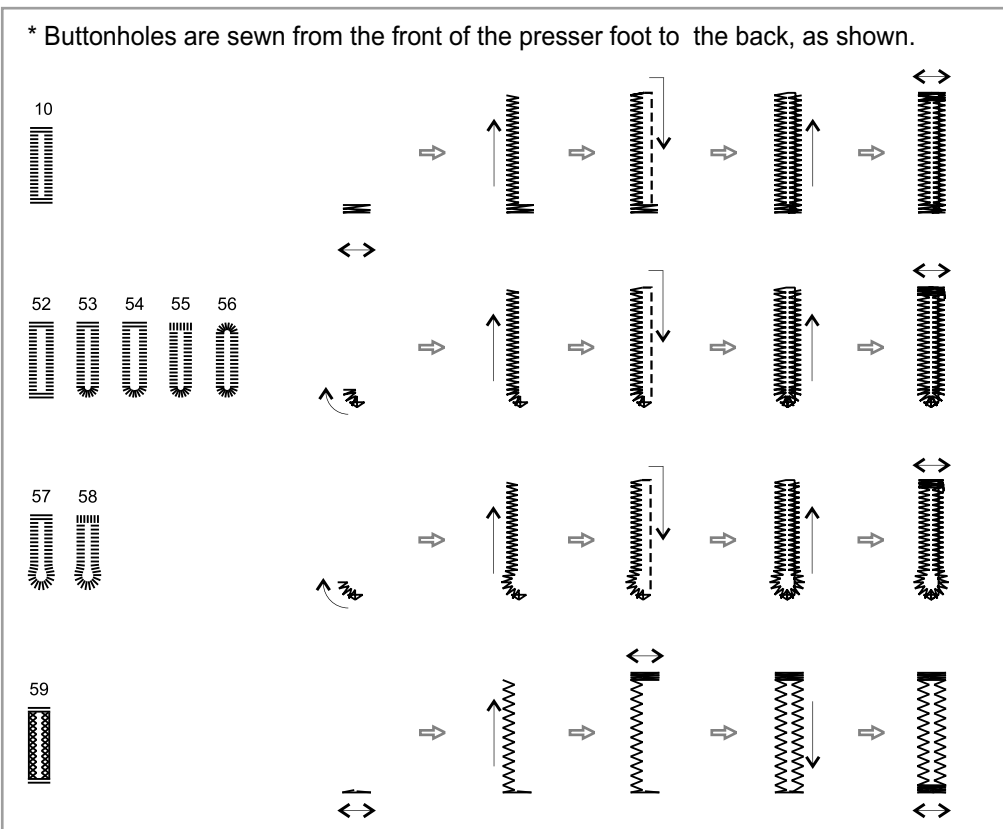

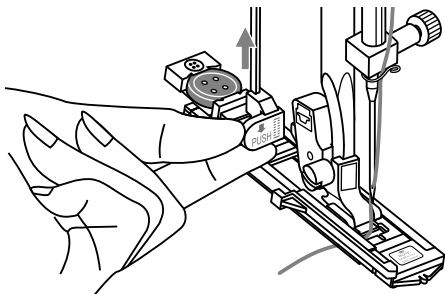

Raise the presser foot and cut thread.

To sew over same buttonhole, raise the presser foot (will return to original position). After sewing the buttonhole stitch, raise the buttonhole lever until it stops.

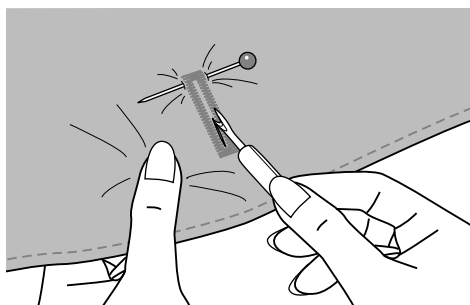

Cut the center of the buttonhole being careful not to cut any stitches on either side. Use a pin as a stopper at the bar tack so you do not cut too much.

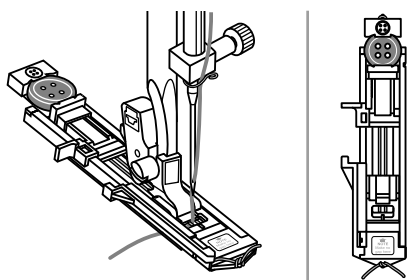

Making a buttonhole on stretch fabrics

When sewing buttonholes on stretch fabric, hook heavy thread or cord under the buttonhole foot.

Attach the buttonhole foot and hook the gimp thread onto the back of the presser foot.

Bring the two gimp thread ends to the front of the foot and insert them into the grooves, then temporarily tie them there. Lower the presser foot and start sewing.

Set the stitch width to match the diameter of the gimp thread.

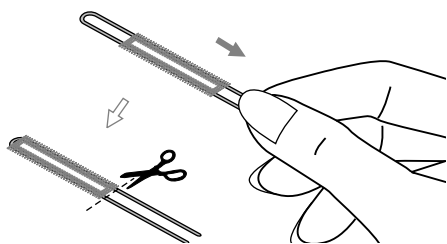

Once sewing is completed, pull the gimp thread gently to remove any slack, then trim off any excess.

➔ Please Note:

It is suggested that you use interfacing on the backside of the fabric.

Eyelet Stitch



Select pattern 60 to get the eyelet stitch.
Attach satin stitch foot (A).

Press the "-" or "+" stitch width adjustment to
button select the eyelet size.

Size of eyelet.

A. Small: 5.0mm (3/16 inch).

B. Medium: 6.0mm (15/64 inch).

C. Large: 7.0mm (1/4 inch).

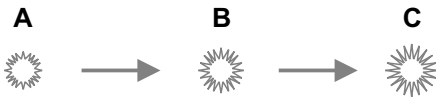

Lower the needle into the fabric at the
beginning of the stitching, and then lower
the presser foot lever.

Once sewing is completed, the machine
automatically sews reinforcement stitches,
then stops.

Make a hole at the center using an eyelet
punch.

* Eyelet punch is not included with the
machine.

Please Note:

If thin thread is used, the stitching may be
coarse. If this occurs, sew the eyelet twice
one on top of the other.

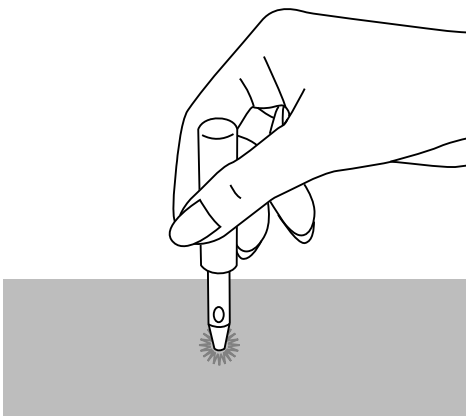

Darning Stitch

<p>50 51</p>	<p>3.5~7.0</p>	<p>1.0~2.0</p>
--------------	----------------	----------------

- 50: Simple darning stitch in thin and medium fabrics
- 51: Reinforced darning stitch in heavy fabrics

Select stitch pattern 50 or 51 to get the darning stitch.
Change the presser foot to the buttonhole foot.

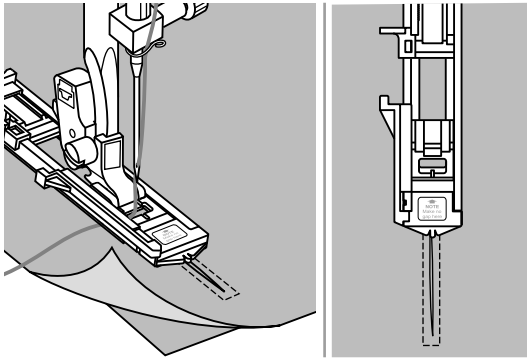

Baste the upper fabric and the under fabric together.
Select the needle position. Lower the presser foot over the center of the tear.

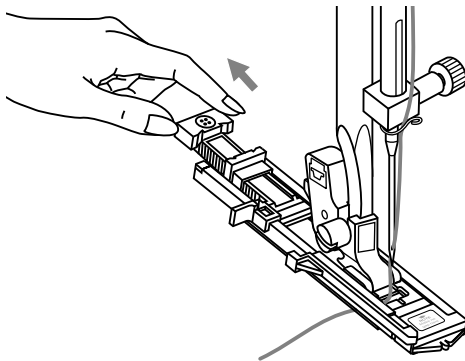

Pull the button holder to rear.
Set the button guide plate on buttonhole foot to the desired length.

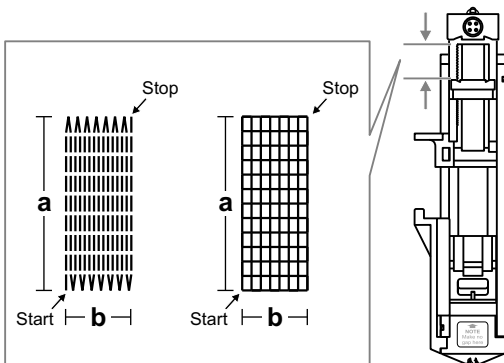

The size of one darn cycle is variable. However, the maximum stitch length is 2.6cm (1 inch) and the maximum stitch width is 7mm (9/32 inch).

- a. The length of sewing.
- b. The width of sewing.

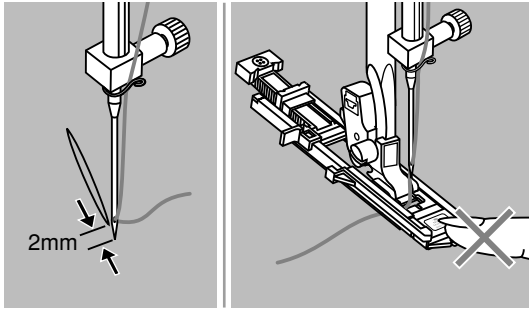

Position the fabric so that the needle is 2mm (1/16 inch) in front of the area to be darned, and then lower the presser foot lever.

➔ Please Note:

When lowering the presser foot, do not push in the front of the presser foot, otherwise the darning will not be sewn with the correct size.

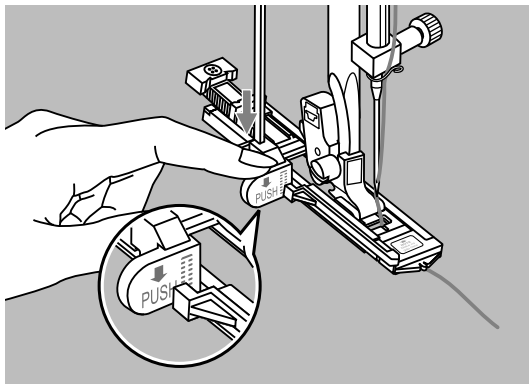

Pass the upper thread down through the hole in the presser foot. Pull down the buttonhole lever .

The buttonhole lever is positioned behind the bracket on the buttonhole foot. Gently hold the end of the upper thread in your left hand, and then start sewing.

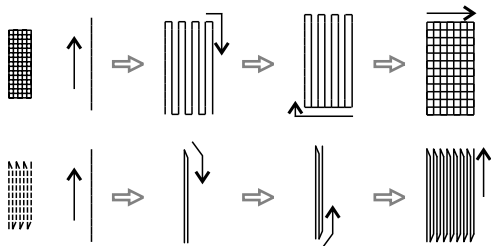

Darning stitches are sewn from the front of the presser foot to the back, as shown.

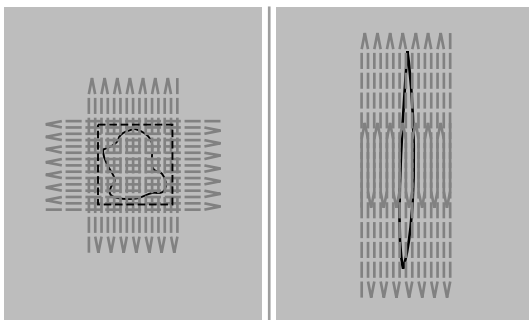

If the sewing range is too big to sew, then we suggest you can sew several times (or cross sew) to get better sewing result.

Zipper Insertion



⚠ Attention:

Zipper foot should be used for sewing width center needle position straight stitch only. It is possible that needle could hit the presser foot and break when sewing other patterns.

Inserting a centered zipper

- Baste the zipper opening on the garment.
- Press open the seam allowance. Place the zipper face down on the seam allowance with the teeth against the seam line. Baste the zipper tape.

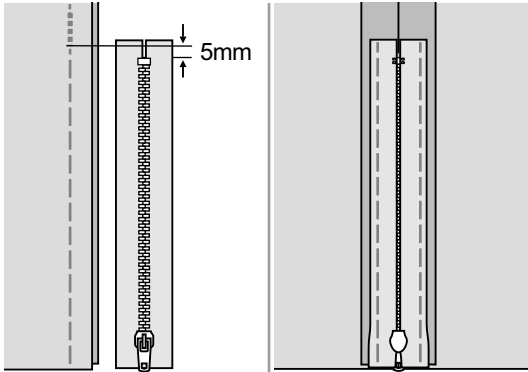

- Attach the zipper foot. Attach the right side of the presser foot pin to the holder when sewing the left side of the zipper.
- Attach the left side of the presser foot pin to the presser foot holder when sewing the right side of the zipper.

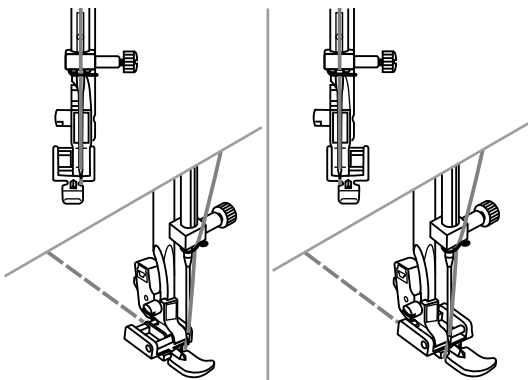

- Stitch left side of the zipper from top to bottom.
- Stitch across the lower end and right side of zipper. Remove the basting and press.

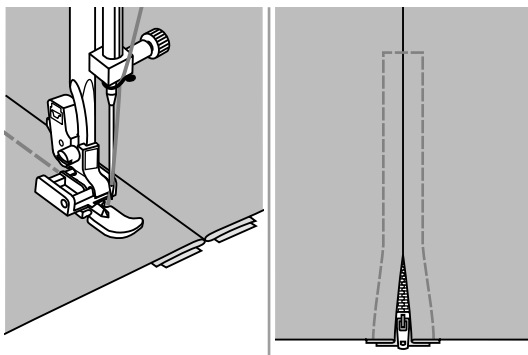

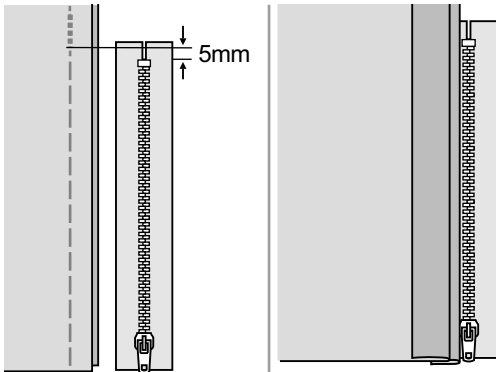

Inserting a side zipper

- Baste the zipper opening on the garment.
- Fold back to the left seam allowance. Turn under the right seam allowance to form 3mm fold.

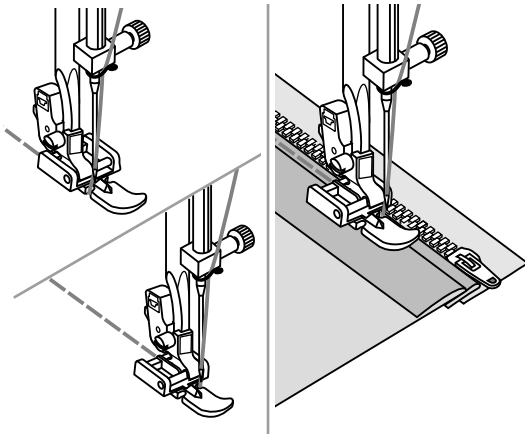

- Attach the zipper foot. Attach the right side of the presser foot pin to the holder when sewing the left side of the zipper. Attach the left side of the presser foot pin to the presser foot holder when sewing the right side of the zipper.

- Stitch the left side of zipper from bottom to top.

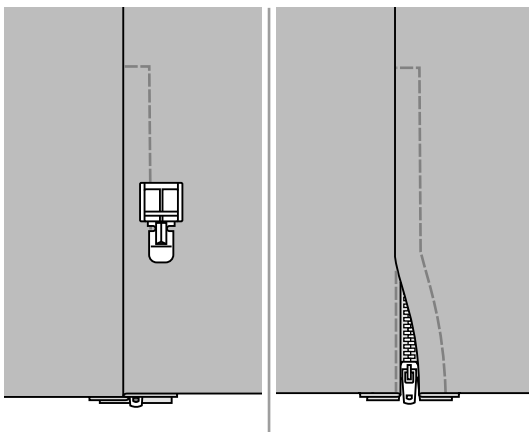

- Turn the fabric right side out, stitch across the lower end and right side of zipper.

- Stop about 5cm (2 inches) from the top of zipper. Remove the basting and open the zipper. Stitch the remainder of the seam.

Invisible zipper insertion



* The invisible zipper foot accessory is optional. It is not included with this machine.

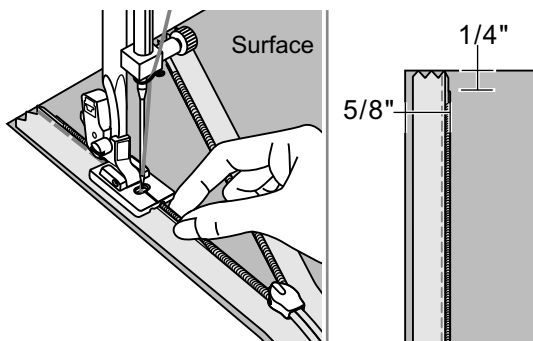

This foot is used to insert invisible zippers so that they are covered by the seam, and thus hidden.

Attach the invisible zipper foot to the machine. Adjust needle center position and straight stitch. Stitch length depends from the fabric. Adjust 1,0 - 3,0 mm.

Place open zipper face - down on right side of fabric as shown picture.

Place the fabric edge at the 5/8 inch marking line on the needle plate surface.

Place the zipper 1/4 inch below raw edge of garment.

With right-hand groove of foot over coil, stitch zipper until the foot hits the slider. Remove the garment from the machine.

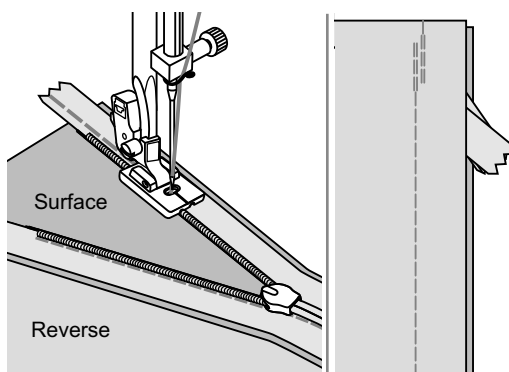

To attach the other half of the zipper, place the fabric edge on the 5/8 inch marking line on the needle plate as shown in picture.

With the left-hand groove of foot over coil, stitch zipper until the foot hits the slider.

Close zipper. Fold the fabric that the zipper is on ride - hand side out of the way as shown in picture.

Use a pin for fixing the fabric. Change to regular sewing foot and saw as close as possible with straight stitch against the zipper.

At last carry out tie off with some forward and reverse stitches.

Narrow Hemming

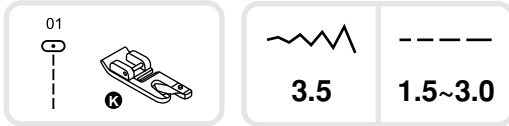

* The hemmer foot accessory is optional. It is not included with this machine.

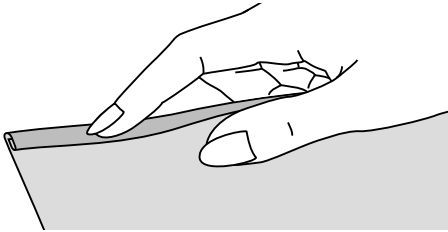

Fold edge of fabric over about 3mm, then fold it over again 3mm for about 5cm along the edge of the fabric.

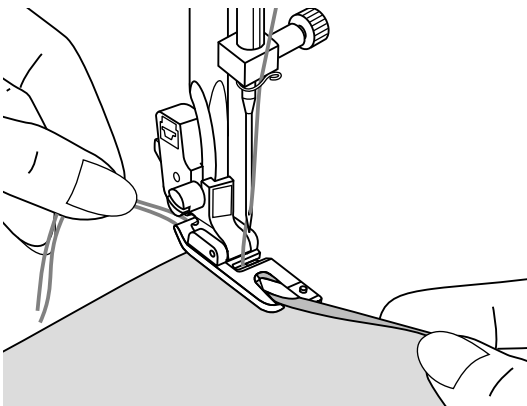

Insert the needle into the fold by rotating the handwheel toward you, and lower the presser foot. Sew several stitches and raise the presser foot.

Insert the fabric fold into the spiral opening of hemmer foot. Move fabric back and forth until the fold forms a scroll shape.

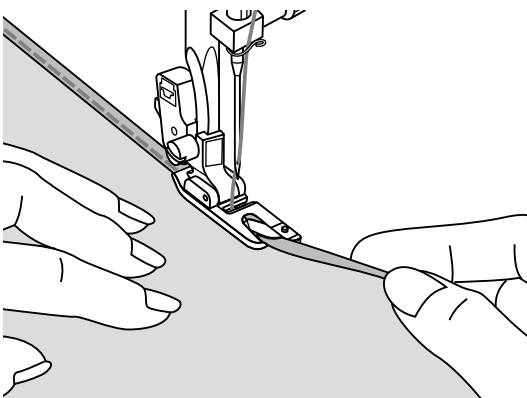

Lower the presser foot and start sewing slowly guiding the raw edge of the fabric in front of the hemmer foot evenly into the scroll of the foot.

Cording

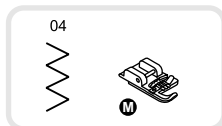

* The cording foot accessory is optional. It is not included with this machine.

Sew over one strand of cording to create a pretty swirled design on a jacket or vest or sew over three strands of cording for border trims. Pearl cotton, knitting yarn, embroidery floss, lace thread, fine wool or lily yarn can be used for cording.

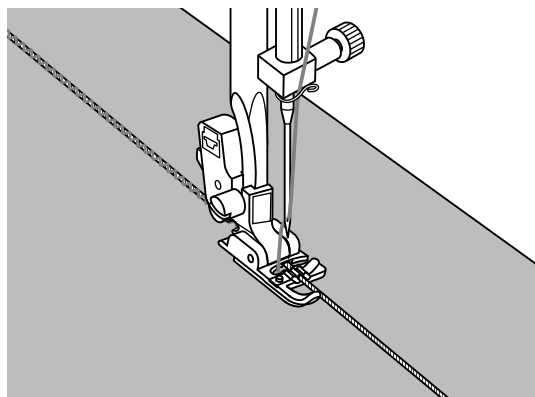

Single cording

Mark the design on the fabric. Insert the cord in the center groove of the cording foot from the right side opening. Pull the cord about 5cm (2 inches) behind the foot.

The grooves under the foot will hold the length of the cord in place while the stitches are being formed over the cord.

Select the stitch and adjust the stitch width so that the stitches are just covering the cord. Lower the foot and sew slowly, guiding the cord over the design.

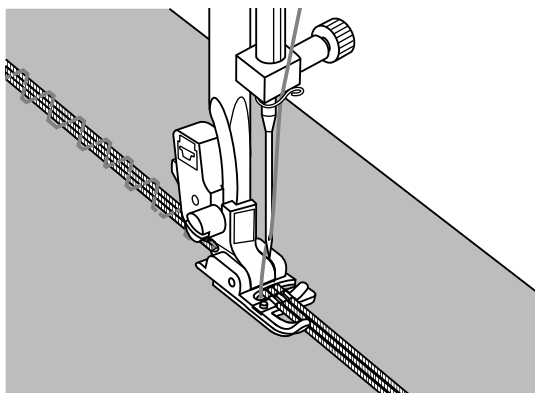
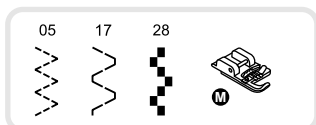

Triple cording

Push the sewing thread to the left and insert three cords into the grooves of the foot and pull about 5cm (2 inches) of the cords behind the foot.

Select the desired pattern and adjust the stitch width so that the stitches are just covering the cords. Lower the foot and sew slowly guiding the cords.

Satin Stitch Sewing

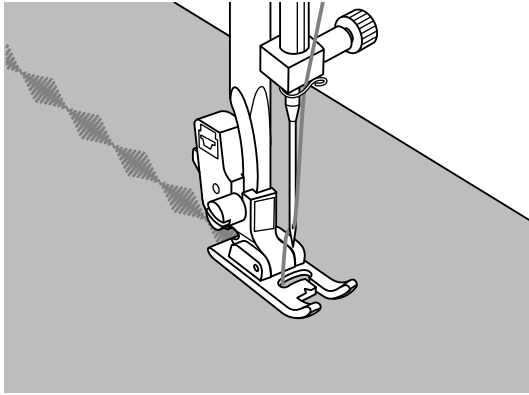
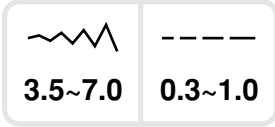
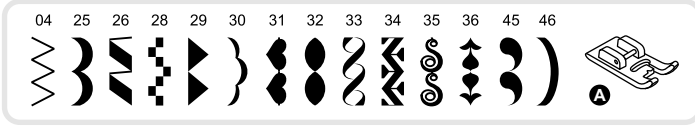

Use the satin stitch foot for satin stitching and sewing decorative stitches. This foot has a full indentation on the underside to allow easy sewing over the thickness of the stitches formed by closely spaced zigzag stitches, and even feeding of the fabric.

To tailor the satin or decorative stitch pattern, you may adjust the length and width of the pattern by pressing the stitch length and width adjustment buttons. Experiment with fabric scraps until you get the desired length and width.

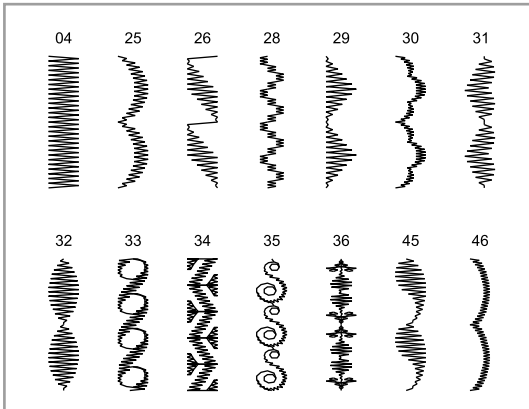

Please Note:

When sewing very thin fabrics, it is suggested that you use interfacing on the backside of the fabric.

Quilting

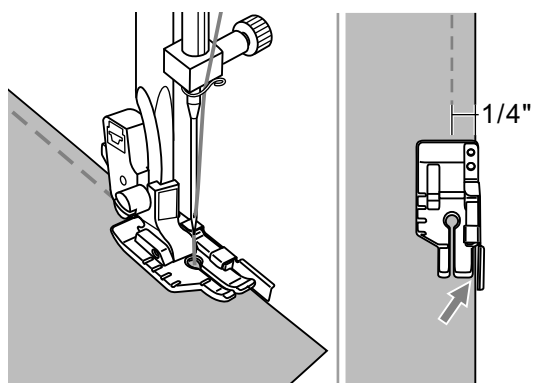
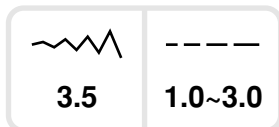
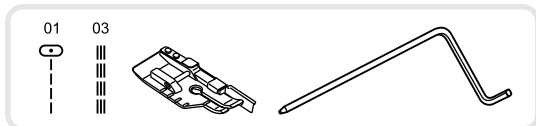

* The 1/4" quilting foot accessory is optional. It is not included with this machine.

Patchwork stitching

Align the edges of the fabric with inside edge of guide on the side of the foot for accurate 1/4" piecing.

➔ Note:

Only the straight stitch in the center position can be used.

The inside of the toes provides an accurate 1/8" seaming guide.

The foot has 1/4" markings both behind the needle and in front of the needle for accurate pivoting of corners.

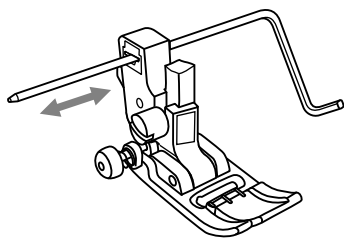

Using the edge/quilting guide

Insert the edge/quilting in the presser foot holder as illustrated and set the space as you desire.

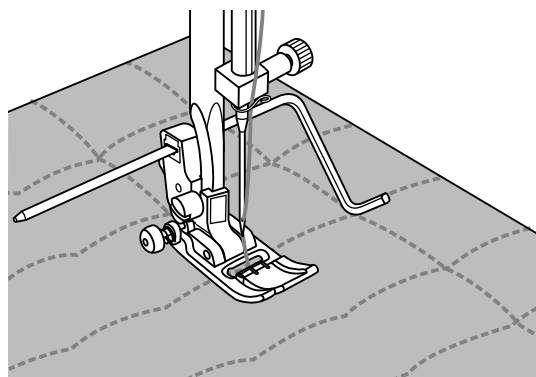

Sew the first row and move over the fabric to sew successive rows with the guide riding along the previous row of stitching.

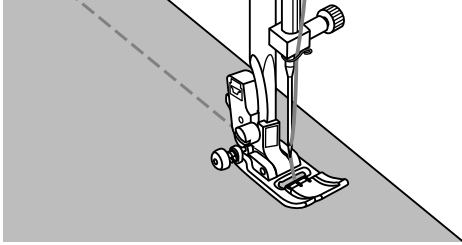

Hand look quilting

You can duplicate the look of a hand look quilt stitch by using monofilament thread in the needle, 30 or 40 weight cotton thread in the bobbin, and increasing the needle tension.

The needle tension will need to be determined by the thickness of your batting.

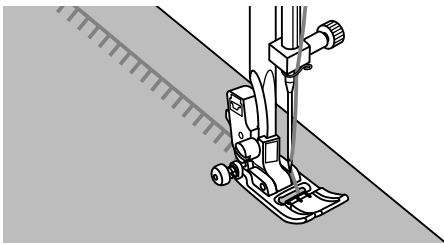

Blanket (Quilting Applique)

For all fabrics and all types of work.

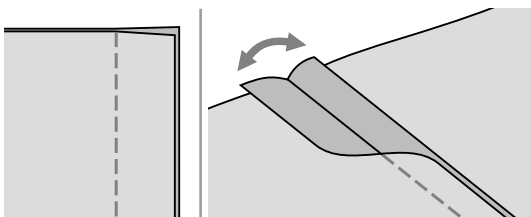
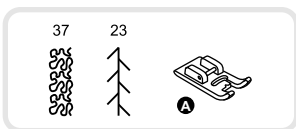

Patchwork stitching

Place the two pieces of fabric with the right side together and sew with the straight stitch.

Open the seam allowance and press it flat.

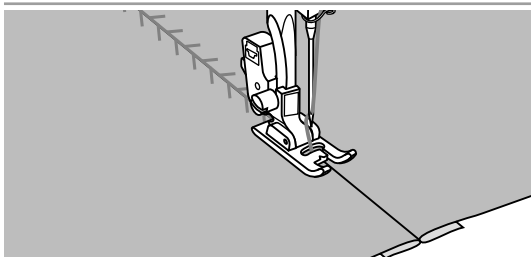

Place the center of the presser foot on the seam line of the joined pieces of fabric and sew over the seam.

Fagoting

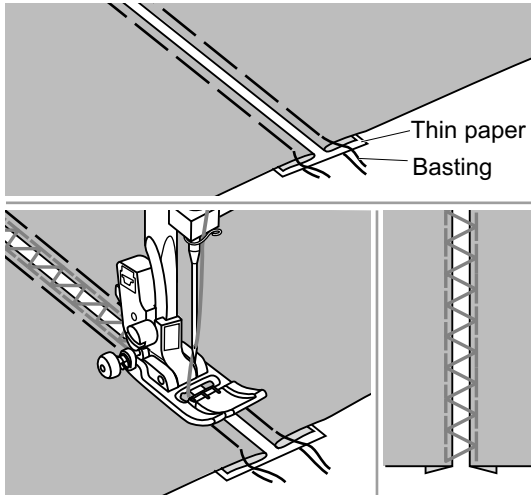
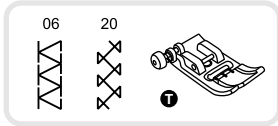

- Separate the folded edges of the fabric pieces with a gap of 4mm (1/8 inch) and baste them onto a piece of thin paper or water-soluble stabilizer sheet.

- Align the center of the presser foot with the center of the two pieces of fabric and begin sewing.

- After sewing, remove the paper.

Scallop Stitch

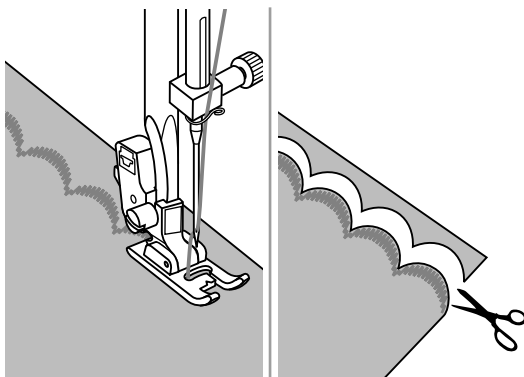
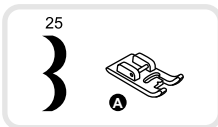

- Stitch along the edge of the fabric, making sure not to sew directly on the edge of the fabric.

For better results, apply spray starch onto the fabric and press with a hot iron before it is sewn.

- Trim along the stitches.
Be careful not to cut the stitches.

Gathering

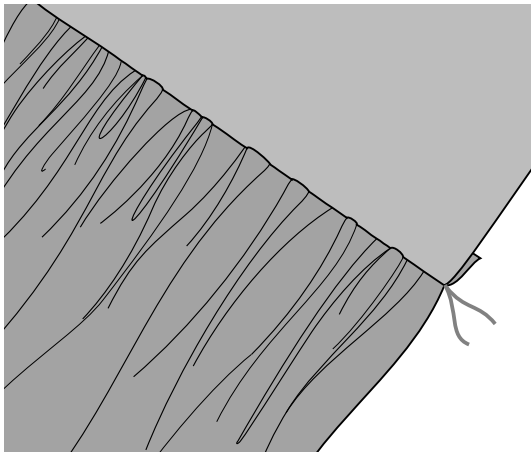
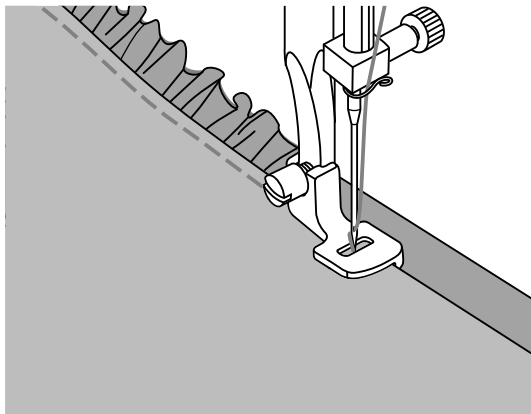
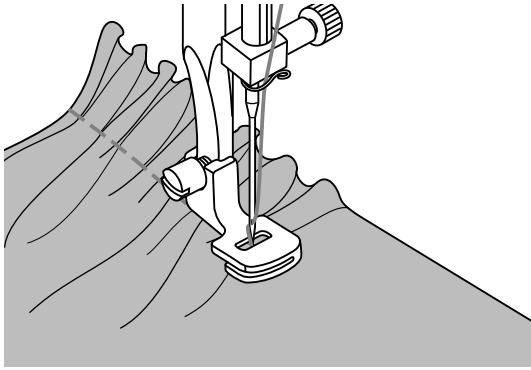
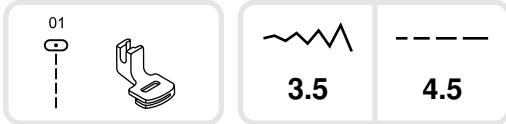

* The gathering foot accessory is optional. It is not included with this machine.

Gathered fabric

Remove the presser foot holder and attach the gathering foot, lowering the tension setting to below 2.

Place fabric to be gathered under presser foot to the right of the presser foot. Sew a row of stitching, keeping the raw edge of fabric aligned with the right edge of foot.

The stitches automatically cause the fabric to gather. Suitable for light to medium weight fabrics.

To gather and attach gathered fabric in one step

Look closely at the gathering foot to see a slot on the bottom.

When using the slot, you can gather the bottom layer of the fabric while attaching it to a flat top layer, such as the waistband on a dress bodice.

1. Remove the presser foot holder and attach gathering foot.
2. Place the fabric to be gathered with right side up under the foot.
3. Place top layer of the fabric right side down in the slot.
4. Guide the two layers as illustrated.

Note:

- When testing machine for adjustments to achieve desired fullness, work with 10" increments of the fabric, trims or elastic. This makes it easier to determine the adjustments and how much change is needed for your project. Always test on your project fabric and on the same grainline as will be used in your finished project.

Using the crossgrain of the fabric will make prettier gathers than the straight of grain.

- Sew slow to medium speed for better fabric control.

Smocking

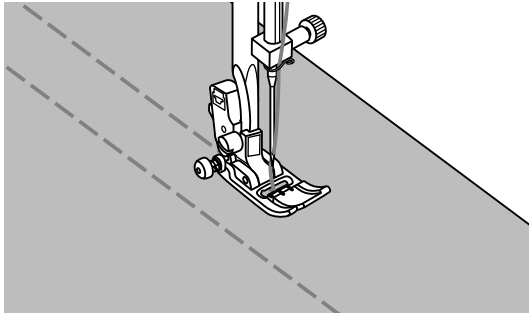
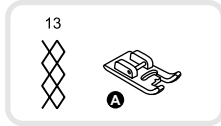
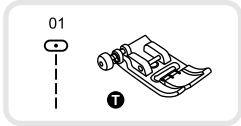

Adjust the stitch length to 4.0mm and loosen the thread tension.

Use the all purpose foot to sew straight lines 1cm (3/8 inch) apart, across the area to be smocked.

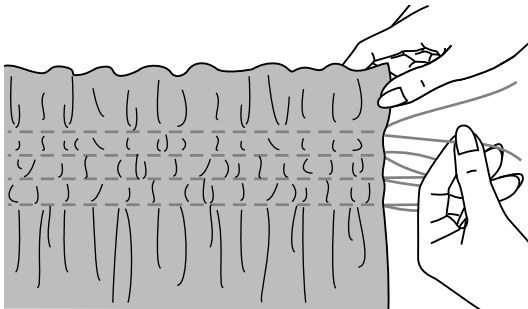

Knot the threads along one edge.

Pull the bobbin threads and distribute the gathers evenly. Secure the threads at the other end.

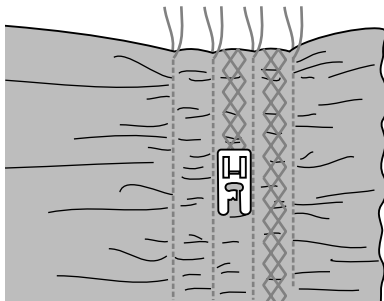

Reduce the tension, if necessary and sew decorative pattern stitches between the straight seams.

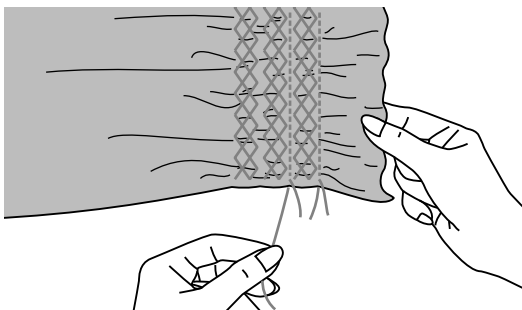

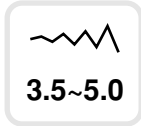
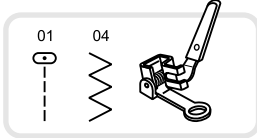

Pull out the gathering stitches.

Free Motion Darning, Embroidery and Monogramming

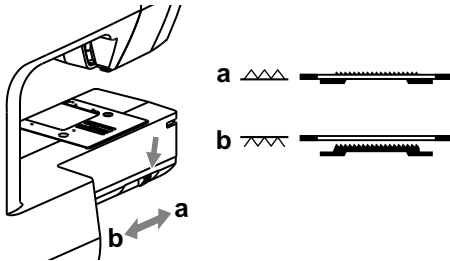

* The darning/ Embroidery foot accessory is optional. (for model London 7)



Move the drop feed control to "  " to lower the feed dogs.

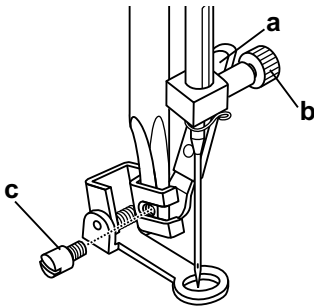

Remove the presser foot holder, and attach the darning foot to the presser foot holder bar.

The lever (a) should be behind the needle clamp screw (b). Press the darning foot on firmly from behind with your index finger and tighten the screw (c).

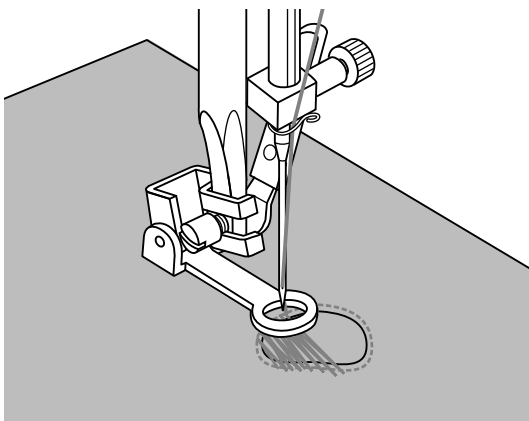

Darning

First sew around the edges of the hole (to secure the threads). Working from left to right, sew over the hole in a constant and continuous movement.

Turn the work by 1/4 (90°) and sew over the first stitching moving the work slower over the hole to separate the threads and not form big gaps between the threads.

Please Note:

Free motion darning is accomplished without the sewing machine internal feed system. Movement of the fabric is controlled by the operator. It is necessary to coordinate sewing speed and movement of fabric.

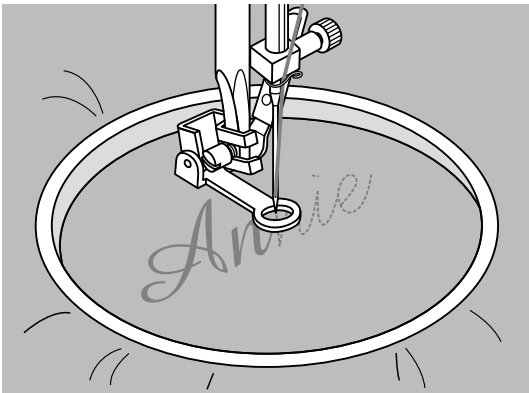
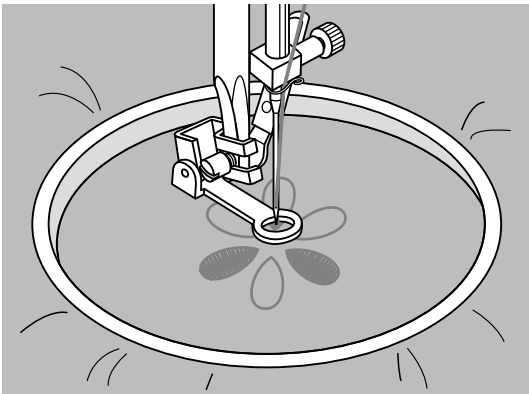
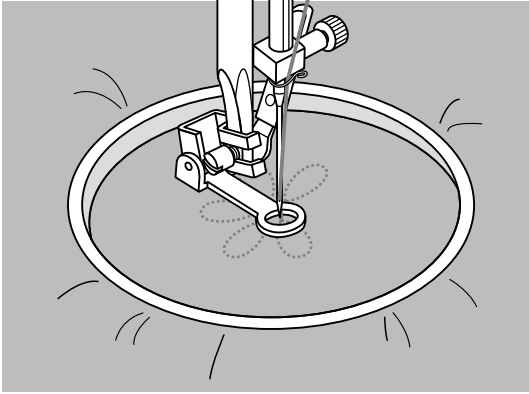

Embroidery

Select zigzag stitch pattern and adjust the stitch width as desired.

Stitch along the outline of the design by moving the embroidery hoop. Make sure to maintain a constant speed.

Fill in the design working from the outline towards the inside. Keep the stitches close together.

You will get longer stitches by moving the hoop faster and shorter stitches by moving the hoop more slowly.

Secure with a reinforcement stitches at the end by pressing the Auto-lock button.

Monogramming

Select the zigzag stitch pattern and adjust the stitch width as desired. Sew at a constant speed, moving the hoop slowly along the lettering.

When the letter is finished. Secure with a reinforcement stitches at the end by pressing the Auto-lock button.

* Embroider hoop is not included with the machine.

Walking Foot

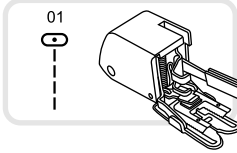

* The walking foot accessory is optional. It is not included with this machine.

Always try to sew first without the walking foot accessory which should be used only when necessary.

It is easier to guide the fabric and you have a better view of the seam when using the standard, regular foot on your machine.

Your sewing machine offers excellent stitch quality on a wide range of fabrics from delicate chiffons to multiple layers of denim.

The Walking Foot accessory equalizes the feeding of the upper and lower layers of fabric and improves the matching of plaids, stripes and patterns. It also helps to prevent uneven feeding of very difficult fabrics.

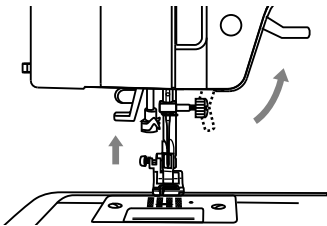

Lift the presser foot lifter to raise the presser foot bar.

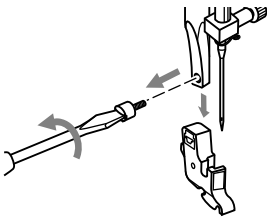

Remove the presser foot holder by unscrewing (counterclockwise) the presser bar attaching screw.

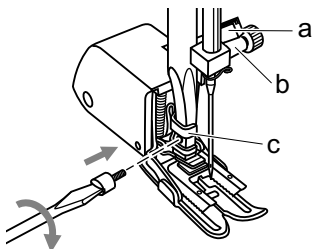

Attach the Walking Foot to the machine as follows:

- The arm (a) should fit into above the needle screw and clamp (b).
- Slide the plastic attaching head (c) from your left to right so that it is fitted into the presser foot bar.
- Lower the presser foot bar.
- Replace and tighten (clockwise) the presser bar attaching screw.
- Make sure both the needle screw and the presser bar attaching screw are tightly secured.

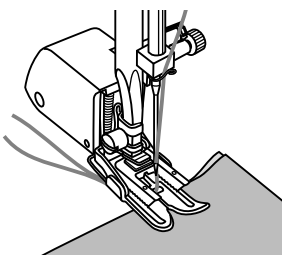

Draw the bobbin thread up and place both the bobbin thread and the needle thread behind the walking foot attachment.

Mirror Stitch Pattern - model London 8

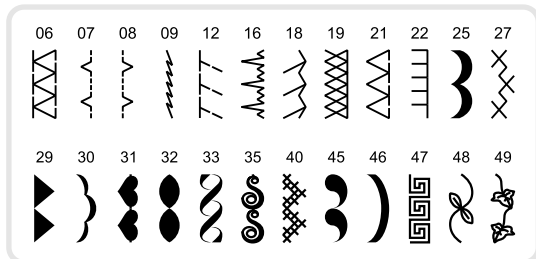

➔ Please Note:

All patterns that can be mirrored are shown in the picture on the left.

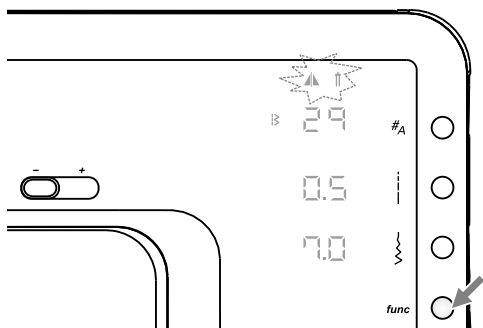

Select the pattern. (e.g. Stitch 29)

Press the function button to open the function program.

➔ Please Note:

Initially both mirror and twin needle symbol are flashing at the same speed.

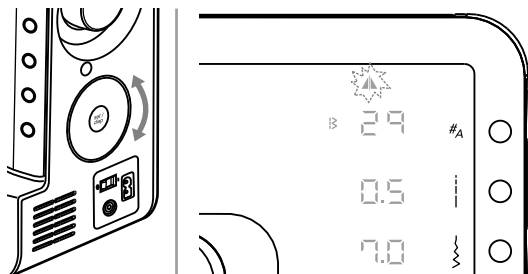

Use selector wheel to scroll to the mirror function.

➔ Please Note:

When starting to scroll only the selected function will flash.



Press Set/disp button to toggle mirror function and memorize it.

➔ Please Note:

Mirror imaged patterns can also be combined with other patterns.

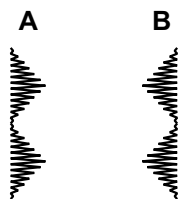

A. Normal pattern sewing.

B. Mirror pattern sewing.

Twin Needle Sewing - model London 8

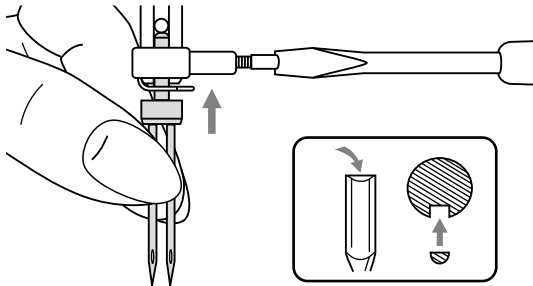

➔ Please Note:

Twin needles must be purchased separately. They are not include with this machine.

Insert the twin needle.

⚠ Attention:

When using twin needles, use the all purpose foot.

Use only twin needle assemblies with max. 2mm needle distance (i.e. bernette part number 502020.62.91)

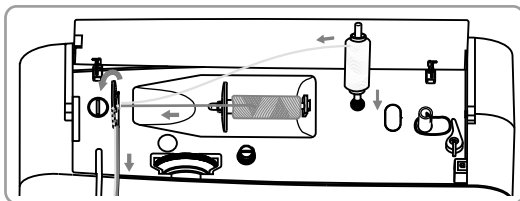

Follow the instructions for single-needle threading using the horizontal spool pin. Thread through the left needle.

Set the spool pin (included with the accessories) into the hole on the top of the machine.

Thread through the same path, making certain to omit the thread guide above the needle and pass thread through the right needle.

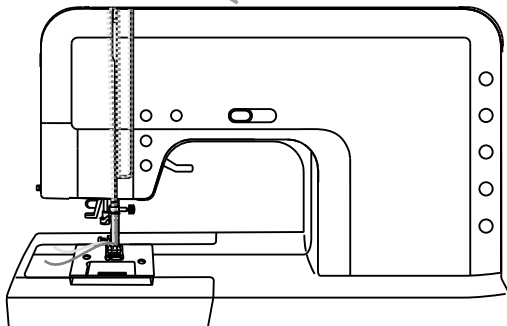

Thread each needle separately.

➔ Please make note:

Make sure that the two threads used to thread the twin needle are of the same weight. You can use one or two colors.

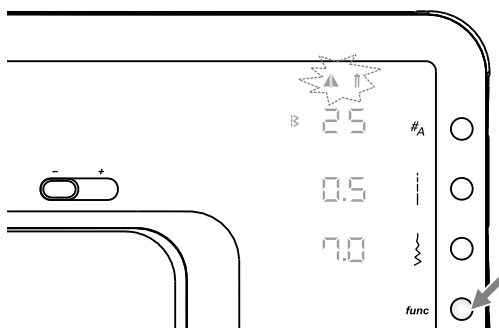

Select the pattern.

Press the function button to open the function program.

➔ Please Note:

Pattern 10, 50-60 and alphabets cannot be used for twin needle sewing.

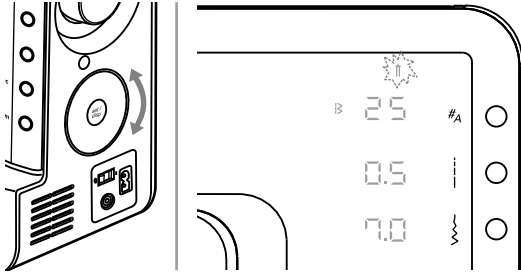

Use selector wheel to scroll to the twin needle function.

➔ Please Note:

Initially both mirror and twin needle symbol are flashing at the same speed. When starting to scroll only the selected function will flash.

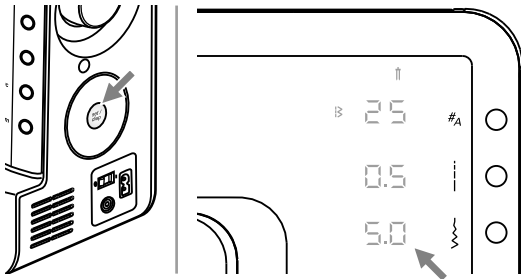

Press Set/dispatch button to toggle twin needle function and memorize it.

The machine automatically reduces the maximum width for twin needle sewing.

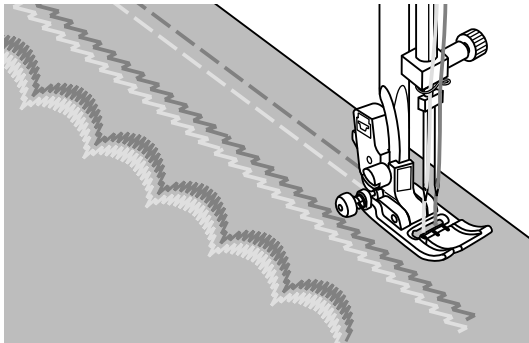

Start to sew and two lines of stitching are sewn parallel to each other.

➔ Please Note:

- When sewing with twin needle, always proceed slowly, and make sure to maintain a low speed to insure quality stitching.
 - When twin needle is selected it will remain on, even if the stitch is changed. To reset twin needle select by selection function twin needle once again.
-

Memory - model London 8

Several stitch patterns may be combined to one sewing sequence using the memory function. These pattern sequences are stored for later use. Even when the sewing machine is switched off the memory contents are retained.

➔ Please Note:

- The machine provides one memory with 30 positions.
- Multiple patterns can be selected from the pattern group or the alphabet group and then be sewn in a sequence.
- Pattern 10 and 50-60 cannot be stored.
- While the machine is sewing the memory patterns, the reverse button can not be operated.

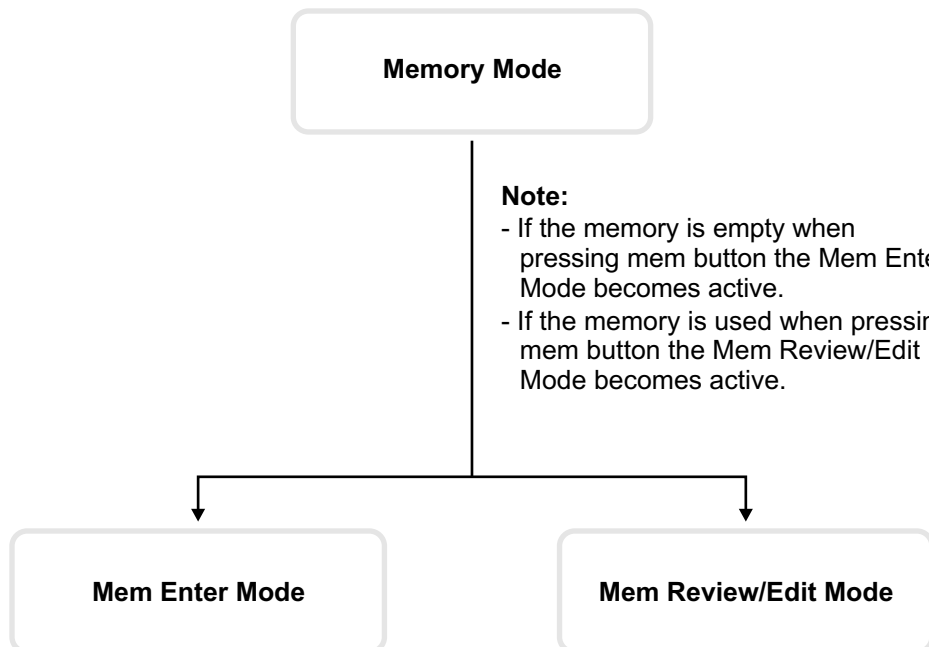

The **Memory Enter Mode** (Stitch number flashing) is used to enter stitches continuously into the Memory.

The **Memory Review/Edit Mode** (Continuous display) is used to review or modify memorized stitches or to add and delete stitches in Memory.

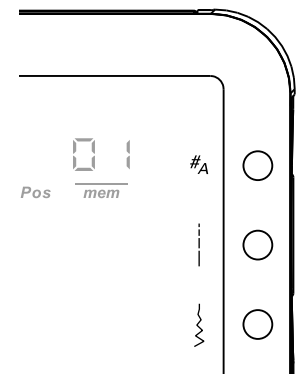
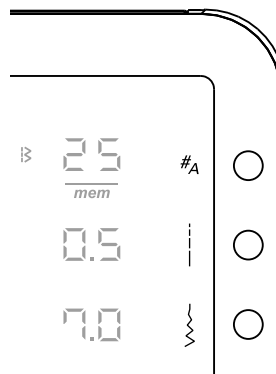
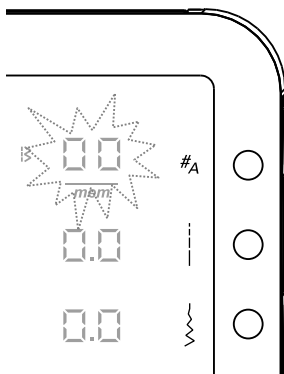

Overview Memory Enter Mode

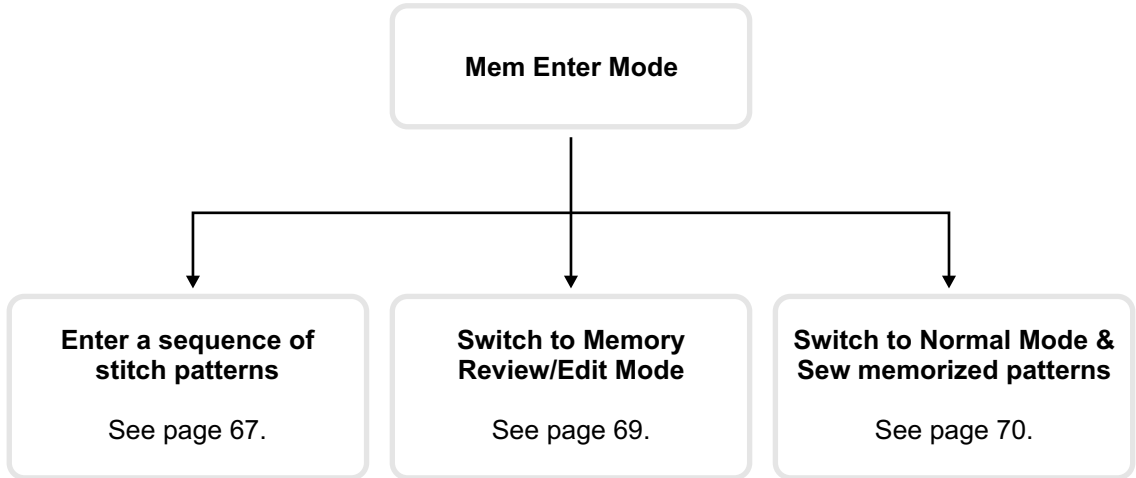

Overview Memory Review/Edit Mode

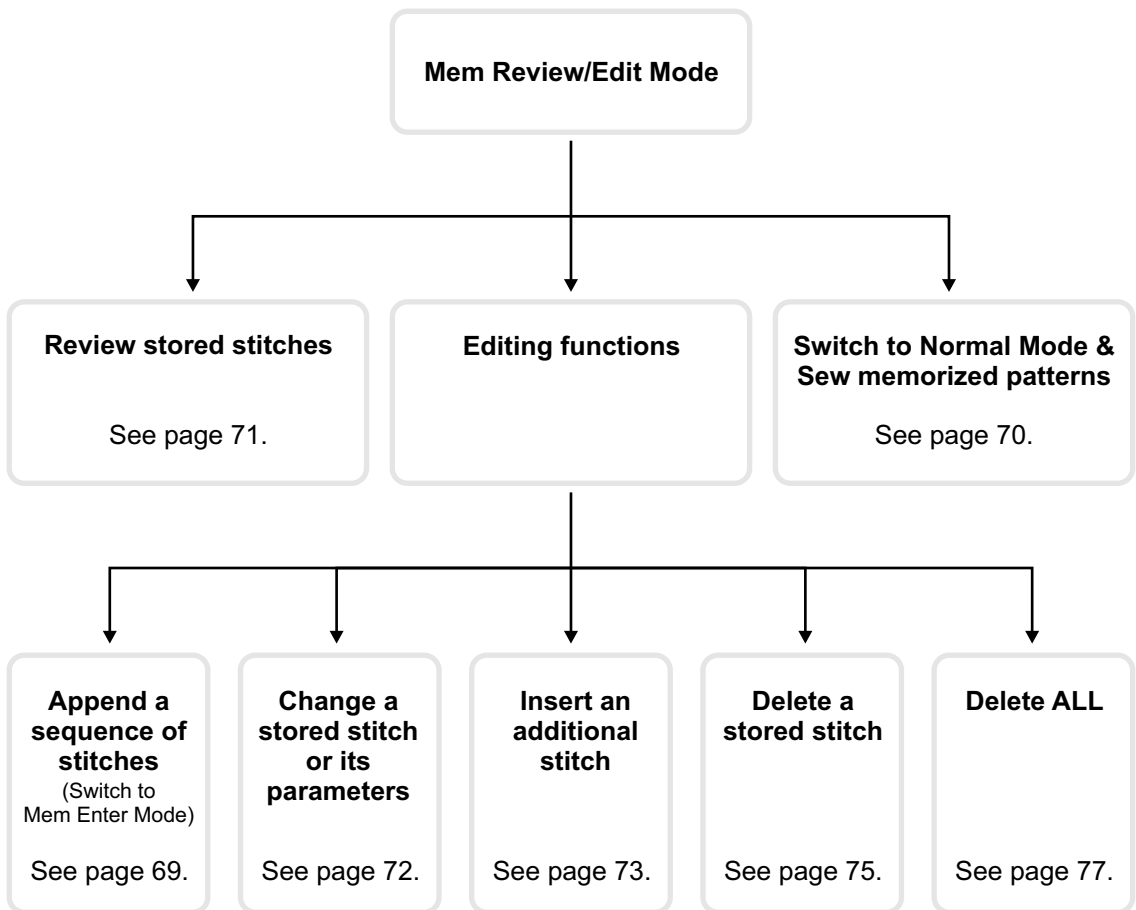

Enter a sequence of stitch patterns in Memory Enter Mode

Precondition: Empty Memory (see page 77 to clear Memory)

Press the memory button to enter Memory Enter Mode.

The stitch number starts flashing.

Memory Mode active is shown by " *mem* " indication under the stitch number.



1st memory position

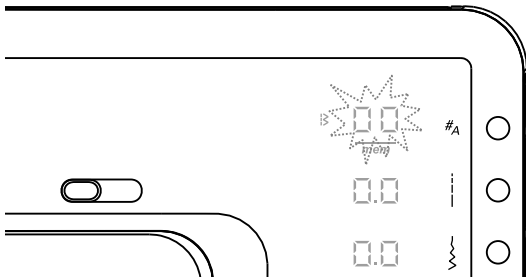

Use selector wheel to select desired stitch.

E.g. stitch 25

1st memory position

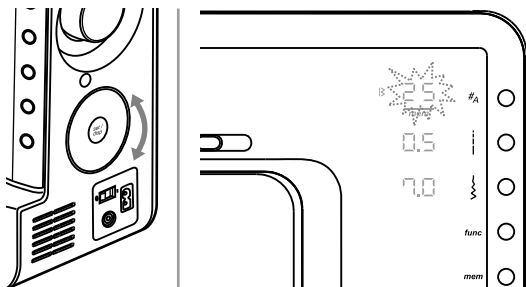

➔ Please note:

Before pressing set/disps button:

- The parameters of the selected stitch, such as stitch length and stitch width, mirroring and twin needle, may be adjusted by pressing the corresponding button.
- The stitch can be test sewn by pressing the start/stop button or the foot controller.

Note, that the machine will automatically stop sewing at the end of the stitch.

1st memory position

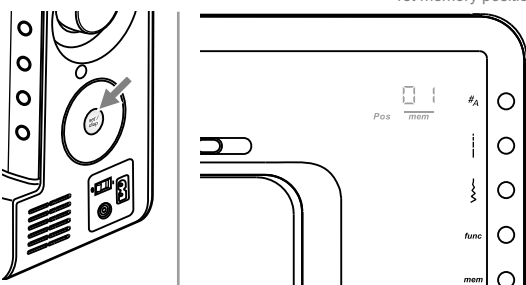

Press set/disps button to memorize it.

After pressing mem position will be shown for 2 seconds (01 = first memory position)

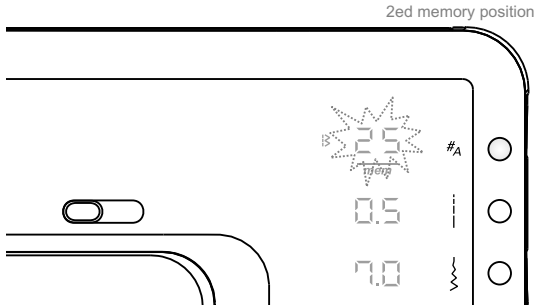

Then stitch number continues to flash with the last programmed stitch and the memory is ready to accept the second stitch.

Repeat above mentioned steps for more stitches to be stored in the memory.

➔ Please Note:

- Patterns and Alphabets can be stored in combination
- Double click pattern group selection button to open the Alphabet selection and repeat above mentioned steps.

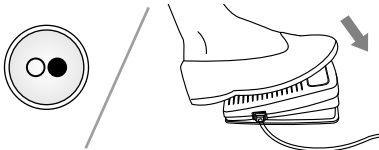

Press the start/stop button or foot controller to sew stored stitches.

➔ Please Note:

When the memory is full with 30 stitches, the machine will beep 3-short beeps.

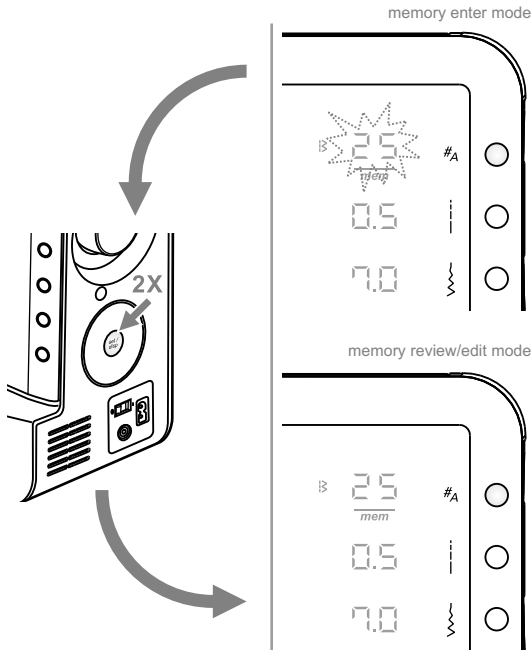

Switch between Memory Enter Mode and Memory Review/Edit Mode

After Memory Enter Mode is activated and at least one stitch is stored double click set/disp button to enter the Memory Review/Edit Mode.

When Memory Review/Edit Mode is active double click set/disp button to enter the Memory Enter Mode.

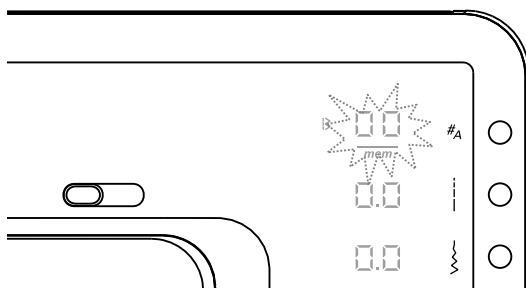

Memory Editing functions - Append a sequence of stitches

Press the memory button to enter the Memory Review/Edit Mode, the screen shows the stitch of the 1st memory position.

Double click set/disp button and the machine switches to Memory Enter Mode starting after the last saved stitch.

Proceed according to page 67/ 68 to add multiple new stitches.

Example:

Stitches in Memory before appending a stitch:

stitch no.	25	26	15
mem pos.	01	02	03

Stitches in Memory after appending stitch no. 01:

stitch no.	25	26	15	01
mem pos.	01	02	03	04

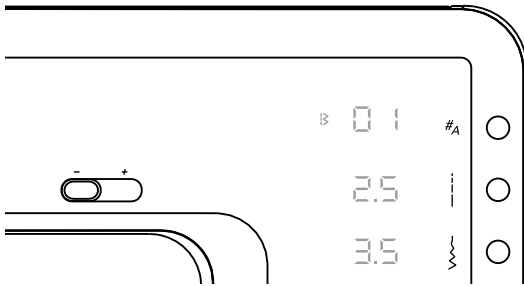

Switch from Memory Mode to the Normal Mode

When Memory Mode is active press memory button to leave the Memory Mode and return to the Normal Mode.

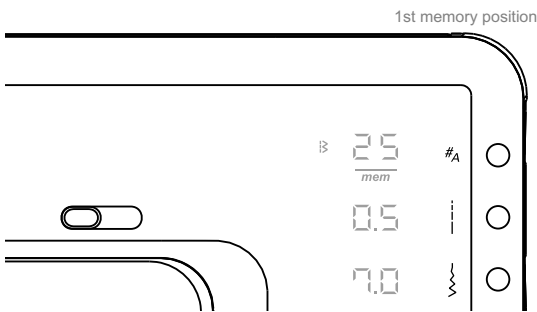

Sew memorized pattern

Press the memory button to enter the Memory Mode, the display shows the stitch of the 1st memory position.

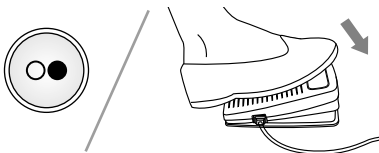

Press the start/stop button or foot controller to sew the stored stitches.

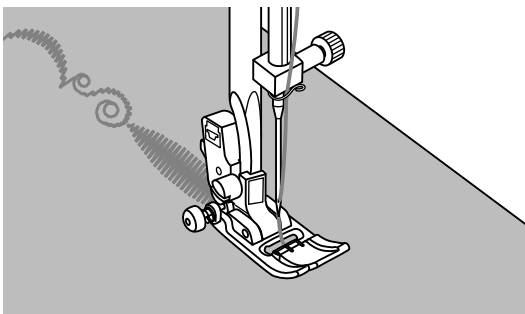

The display will show the sewing stitch data while sewing.

Review stored stitches

Precondition: with existing patterns in Memory

Press the memory button to enter the Memory Review/Edit Mode, the screen shows the stitch of the 1st memory position.

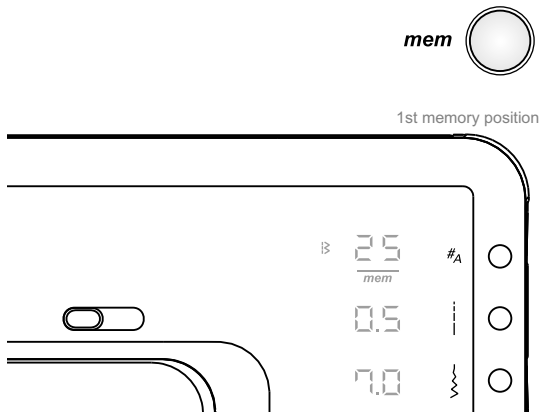

by stitch

Use selector wheel to navigate to different stitches and to review the parameters set.

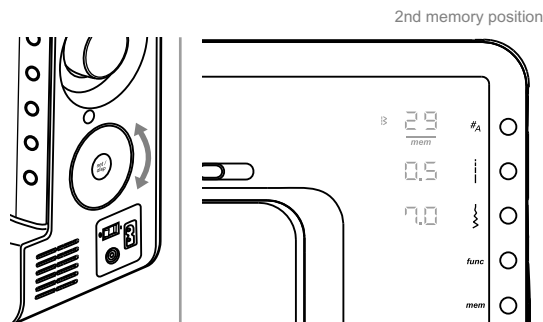

by mem position

Press set/disp button to change to mem position display.

➔ Please Note:

During Memory Review/Edit Mode the display can always be switched between mem Pos and stitch display with the set/disp button.

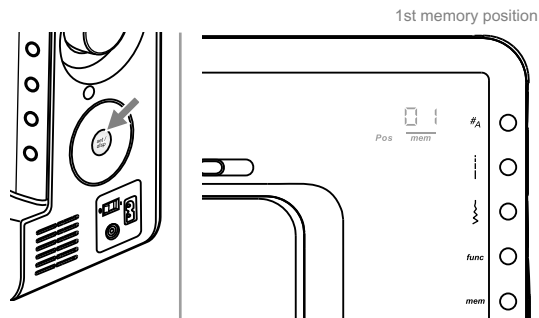

Use selector wheel to navigate to different mem positions.

➔ Please Note:

Press start/stop or foot controller to start continuously sewing from the current position in memory.

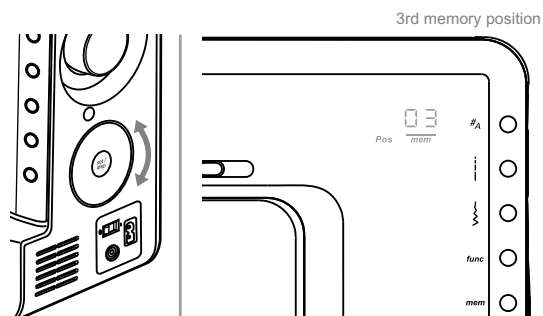

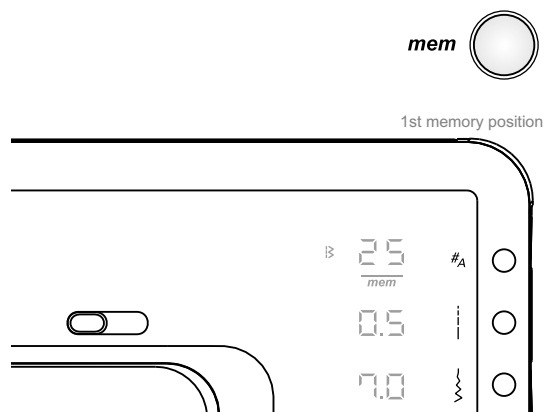

1st memory position

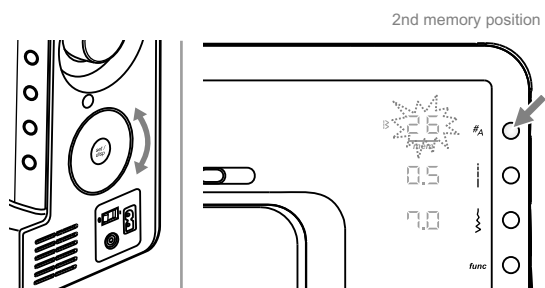

2nd memory position

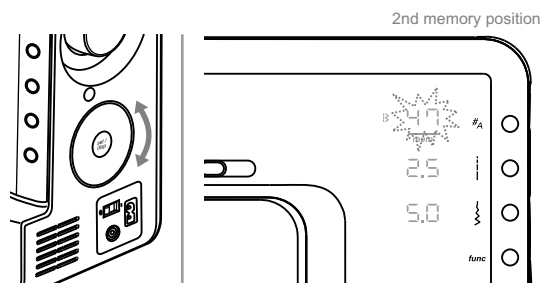

2nd memory position

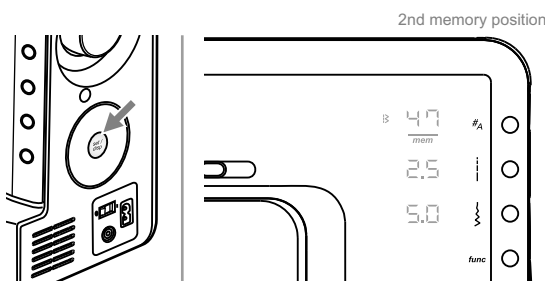

2nd memory position

Memory Editing functions - Change a stored stitch or its parameters

Precondition: with existing patterns in Memory

Press the memory button to enter the Memory Review/Edit Mode, the screen shows the stitch of the 1st memory position.

Use selector wheel to select the stitch that should be replaced or its parameters changed.

To change the stitch press the pattern group selection button, the stitch number starts flashing.

To change its parameters press the stitch length, stitch width or function button.

Use selector wheel to select new value.
(E.g. stitch 47)

➔ Please note:

Before pressing set/disp button:

- The parameters of the selected stitch, such as stitch length and stitch width, mirroring and twin needle, may be adjusted by pressing the corresponding button.
- The stitch can be test sewn by pressing the start/stop button or the foot controller.
Note, that the machine will automatically stop sewing at the end of the stitch.

Press set/disp button to store and return to Memory Review/Edit Mode.

Example:

Stitches in Memory before replacing a stitch:

stitch no.	25	26	15	01	30	48
mem pos.	01	02	03	04	05	06

Stitches in Memory after replacing stitch no. 26:

Stitch no.	25	47	15	01	30	48
mem pos.	01	02	03	04	05	06

Memory Editing functions - Insert an additional stitch

Precondition: with existing patterns in Memory

Press the memory button to enter the Memory Review/Edit Mode, the screen shows the stitch of the 1st memory position.

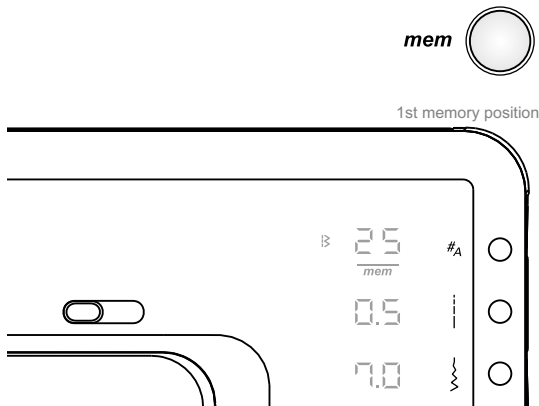

Use selector wheel to select the stitch that you want to insert a new stitch before it.

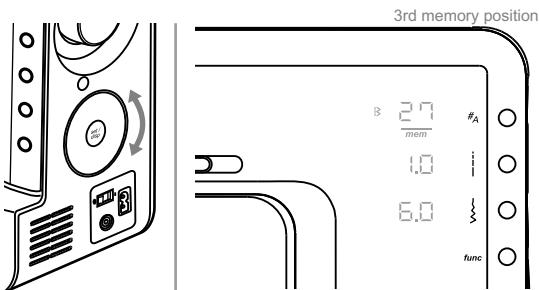

Press the function button to open the function program.

➔ Please Note:

Initially all the function symbols are flashing at the same speed. When starting to scroll only the selected function is flashing.

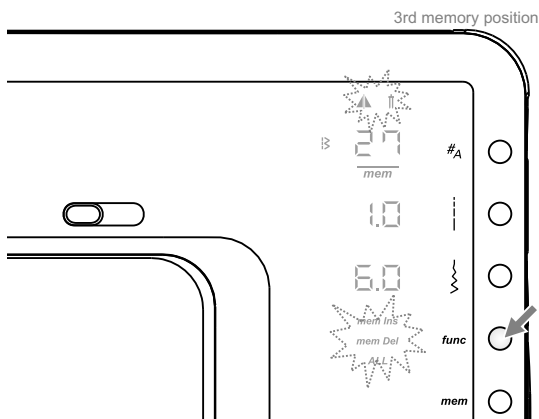

Use selector wheel to scroll to the mem insert function.

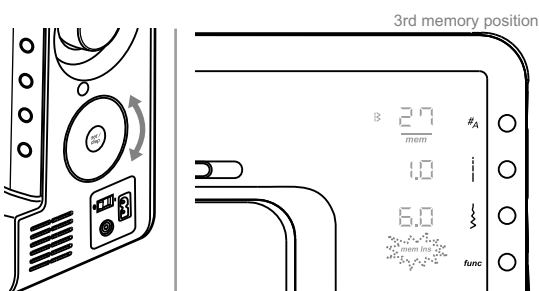

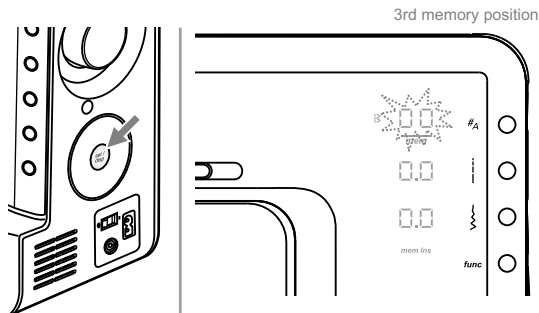

Press set/disp button to insert an empty memory position.

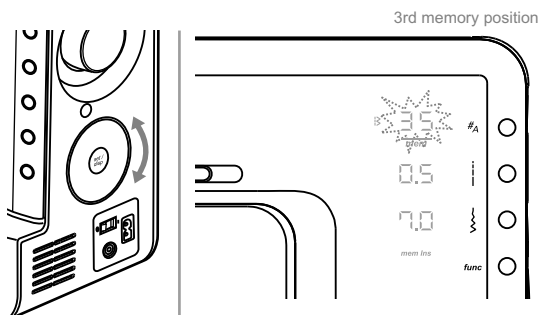

Use selector wheel to select the desired stitch. (E.g. stitch 35)

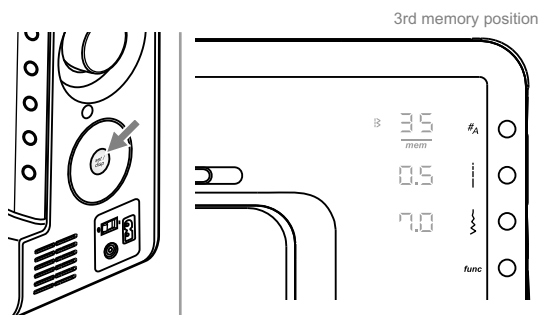

Press set/disp button to store and return to Memory Review/Edit Mode.

➔ Please note:

The parameters of the selected stitch, such as stitch length and stitch width, mirroring and twin needle, may be adjusted by pressing the corresponding button.

Example:

Stitches in Memory before inserting another one:

Stitch no.	25	26	27	01	30	48
mem pos.	01	02	03	04	05	06

Chose stitch no. 27 which is on 3rd memory position.

Stitches in Memory after inserting another one:

stitch no.	25	26	35	27	01	30	48
mem pos.	01	02	03	04	05	06	07

New stitch no. 35 is now on 3rd and stitch no. 27 is now on 4th memory position.

**Memory Editing functions -
Delete a stored stitch**

Press the memory button to enter the Memory Review/Edit Mode, the screen shows the stitch of the 1st memory position.

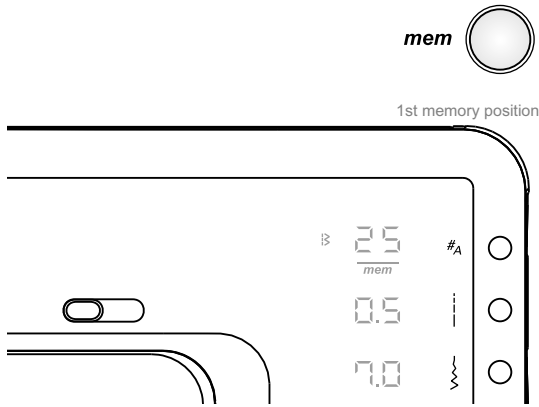

1st memory position

Use selector wheel to select the stitch that you want to delete.

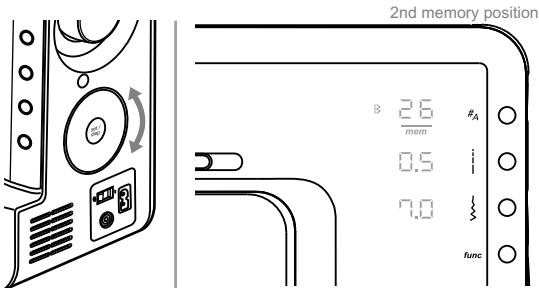

2nd memory position

Press the function button to open the function program.

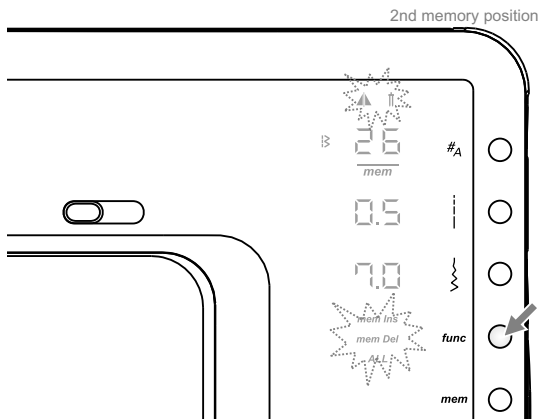

2nd memory position

➡ Please Note:

Initially all the function symbols are flashing at the same speed. When starting to scroll only the selected function is flashing.

Use selector wheel to scroll to the mem delete function.

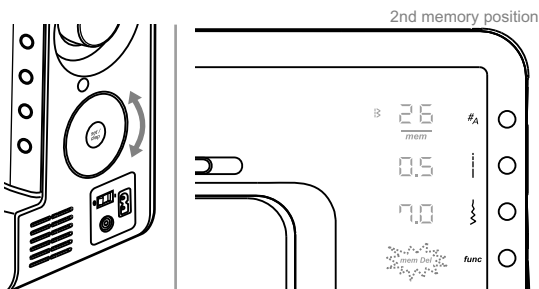

2nd memory position

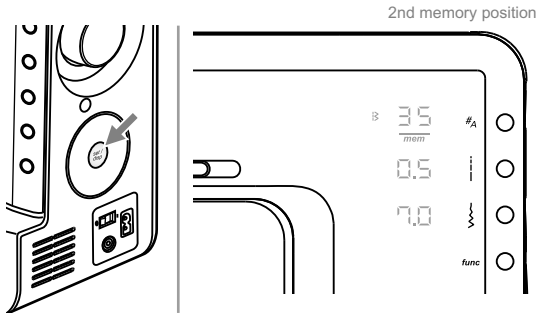

Press set/disp button to delete the pattern and return to the Memory Review/Edit Mode.

Example:

Stitches in Memory before deleting a stitch:

stitch no.	25	26	35	27	01	30	48
mem pos.	01	02	03	04	05	06	07

Chose stitch no. 26 which is on 2nd memory position.

Stitches in Memory after deleting stitch no. 26:

stitch no.	25	35	27	01	30	48
mem pos.	01	02	03	04	05	06

Stitch no. 35 is now on 2nd memory position.

Memory Editing functions - Delete ALL

Press the memory button to enter the Memory Review/Edit Mode, the screen shows the stitch of the 1st memory position.

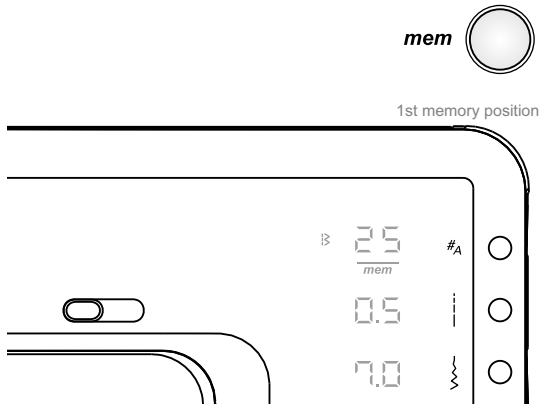

1st memory position

Press function button to open function program.

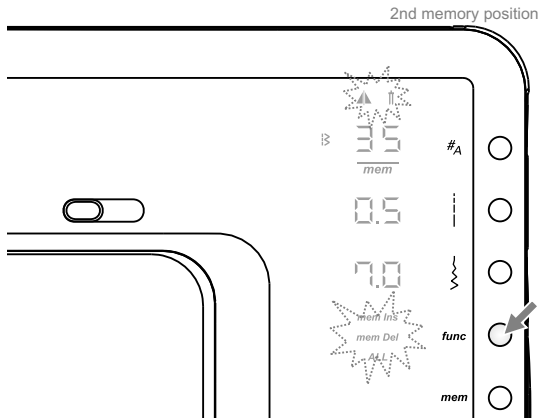

2nd memory position

Use selector wheel to scroll to the mem delete ALL function and press set/disp button.

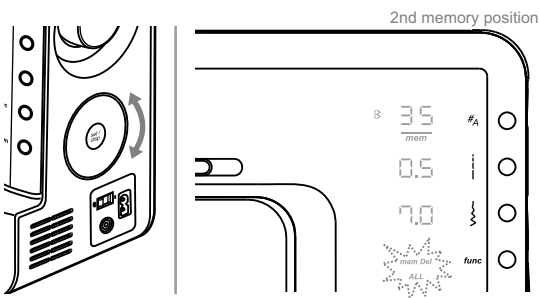

2nd memory position

The display blanks with only "mem" on and mem Del ALL flashing for confirmation.

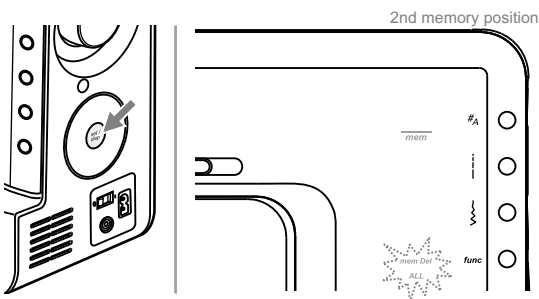

2nd memory position

Press set/disp button again and hold for 2 seconds until the machine beeps.

The memory is deleted and the machine switches into the Memory Enter Mode.

Please Note:

If any other button was pressed or if set/disp button was pressed too short the machine returns into the Memory Review/Edit Mode and the Memory is retained.

Cleaning

⚠ Caution:

Turn main switch off ("O") Disconnect machine from electricity supply before inserting or removing any parts and before cleaning.

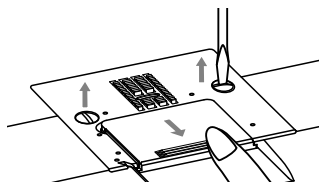

Remove the stitch plate.

Raise the needle to its highest position. Remove the presser foot. Open the bobbin cover plate, remove the two screws, then remove the stitch plate.

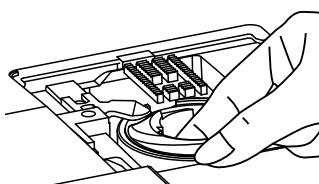

Press the bobbin holder toward to the right, lift it up and remove it.

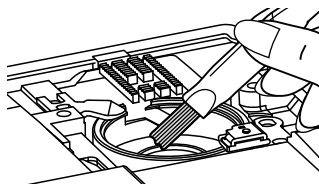

Clean the hook race.

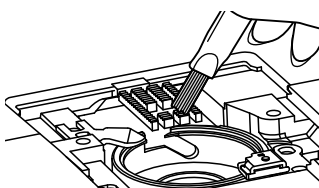

Clean the feed dog and bobbin holder with a brush, then clean them with a soft, dry cloth.

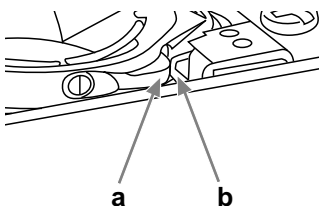

Replace the bobbin holder into the hook race so that the tip (a) fits to the stopper (b). Replace the stitch plate and the two screws. Insert the bobbin. Close the bobbin cover plate, replace the presser foot.

⚠ Important:

Fabric, fluff and threads must be removed regularly.

The drop-in system MUST NOT be lubricated.

Your machine should be serviced at regular intervals at your local dealer.

Replacing the LED Lamp

This appliance is equipped with a durable LED illumination, which is expected to last for the whole lifetime of the equipment. Please contact a local service agent, should the lamp nevertheless require to be replaced

Trouble shooting guide

Before calling for service, check the following items. If the problem still persists, contact the place of purchase or your nearest authorized dealer.

Problem	Cause	Correction	Reference
Upper thread breaks	1. The machine is not threaded correctly.	1. Rethread the machine.	14
	2. The thread tension is too tight.	2. Reduce the thread tension. (Lower number).	18
	3. The thread is too thick for the needle.	3. Select a larger needle.	21
	4. The needle is not inserted correctly.	4. Remove and reinsert the needle (flat side towards the back).	17
	5. The thread is wound around the spool pin.	5. Remove the reel and wind thread onto reel.	14
	6. The needle is damaged.	6. Replace the needle.	17
Lower thread breaks	1. The bobbin case is not inserted correctly.	1. Remove and reinsert the bobbin case and pull on the thread. The thread should pull easily.	13
	2. The bobbin case is threaded wrong.	2. Check both bobbin and bobbin case.	13
	3. The lower thread tension is too tight.	3. Adjusting thread tension as described.	18
Skipped stitches	1. The needle is not inserted correctly.	1. Remove and reinsert needle (flat side towards the back).	17
	2. The needle is damaged.	2. Insert a new needle.	17
	3. The wrong size needle has been used.	3. Choose a needle to suit the thread.	21
	4. The foot is not attached correctly.	4. Check and attach correctly.	32-33
	5. The machine is not threaded correctly.	5. Rethread the machine.	14
	6. The presser foot pressure is not strong enough.	6. Adjusting the presser foot pressure.	18
Needle breaks	1. The needle is damaged.	1. Insert a new needle.	17
	2. The needle is not correctly inserted.	2. Insert the needle correctly (flat side towards the back).	17
	3. Wrong needle size for the fabric.	3. Choose a needle to suit the thread and fabric.	21
	4. The wrong foot is attached.	4. Select the correct foot.	32-33
	5. The needle clamp screw is loose.	5. Use the screwdriver to firmly tighten the screw.	17
	6. The presser foot that is used is not appropriate for the type of stitch pattern that you wish to sew.	6. Attach the presser foot that is appropriate for the type of stitch that you wish to sew.	32-33
	7. The upper thread tension is too tight.	7. Loosen the upper thread tension.	18
Loose stitches	1. The machine is not correctly threaded.	1. Check the threading.	14
	2. The bobbin case is not correctly threaded.	2. Thread the bobbin case as illustrated.	11
	3. Needle/fabric/thread combination is wrong.	3. The needle size must suit the fabric and thread.	21
	4. Thread tension is wrong.	4. Correct the thread tension.	18
Seam gather or pucker	1. The needle is too thick for the fabric.	1. Select a finer needle.	21
	2. The stitch length is adjusted wrong.	2. Readjust the stitch length.	--
	3. The thread tension is too tight.	3. Loosen the thread tension.	18

Problem	Cause	Correction	Reference
Seam puckering	1. The needle thread tension is too tight.	1. Loosen the thread tension.	18
	2. The needle thread is not threaded correctly.	2. Rethread the machine.	14
	3. The needle is too heavy for the fabric being sewn.	3. Choose a needle to suit the thread and fabric.	21
	4. The stitch length is too long for the fabric.	4. Make stitch dense.	--
	5. The presser foot pressure is not correctly adjusted.	5. Adjusting the presser foot pressure.	18
Patterns are distorted	1. The correct presser foot is not used.	1. Select the correct foot.	32-33
	2. The needle thread tension is too tight.	2. Loosen the thread tension.	18
The machine jams	1. Thread is caught in the hook.	Remove the upper thread and bobbin case, turn the handwheel backwards and forwards by hand and remove the thread remnants.	79
	2. The feed dogs are packed with lint.		
The machine is noisy	1. Fluff have collected on the hook or needle bar.	1. Clean the hook and feed dog as described.	79
	2. The needle is damaged.	2. Replace the needle.	17
	3. Slight humming sound coming from internal motor.	3. Normal.	--
	4. Thread is caught in the hook.	Remove the upper thread and bobbin case, turn the handwheel backwards and forwards by hand and remove the thread remnants.	79
	5. The feed dogs are packed with lint.		
Uneven stitches, uneven feed	1. Poor quality thread.	1. Select a better quality thread.	21
	2. The bobbin case is threaded wrong.	2. Remove the bobbin case, the thread and reinsert correctly.	13
	3. Fabric has been pulled.	3. Do not pull on the fabric while sewing, let it be taken up by the machine.	--
The sewing machine doesn't operate	1. The machine is not turned on.	1. Turn on the machine.	8
	2. The machine is not plugged in.	2. Connect the power line plug to the electric outlet.	8

Flowchart Normal Mode

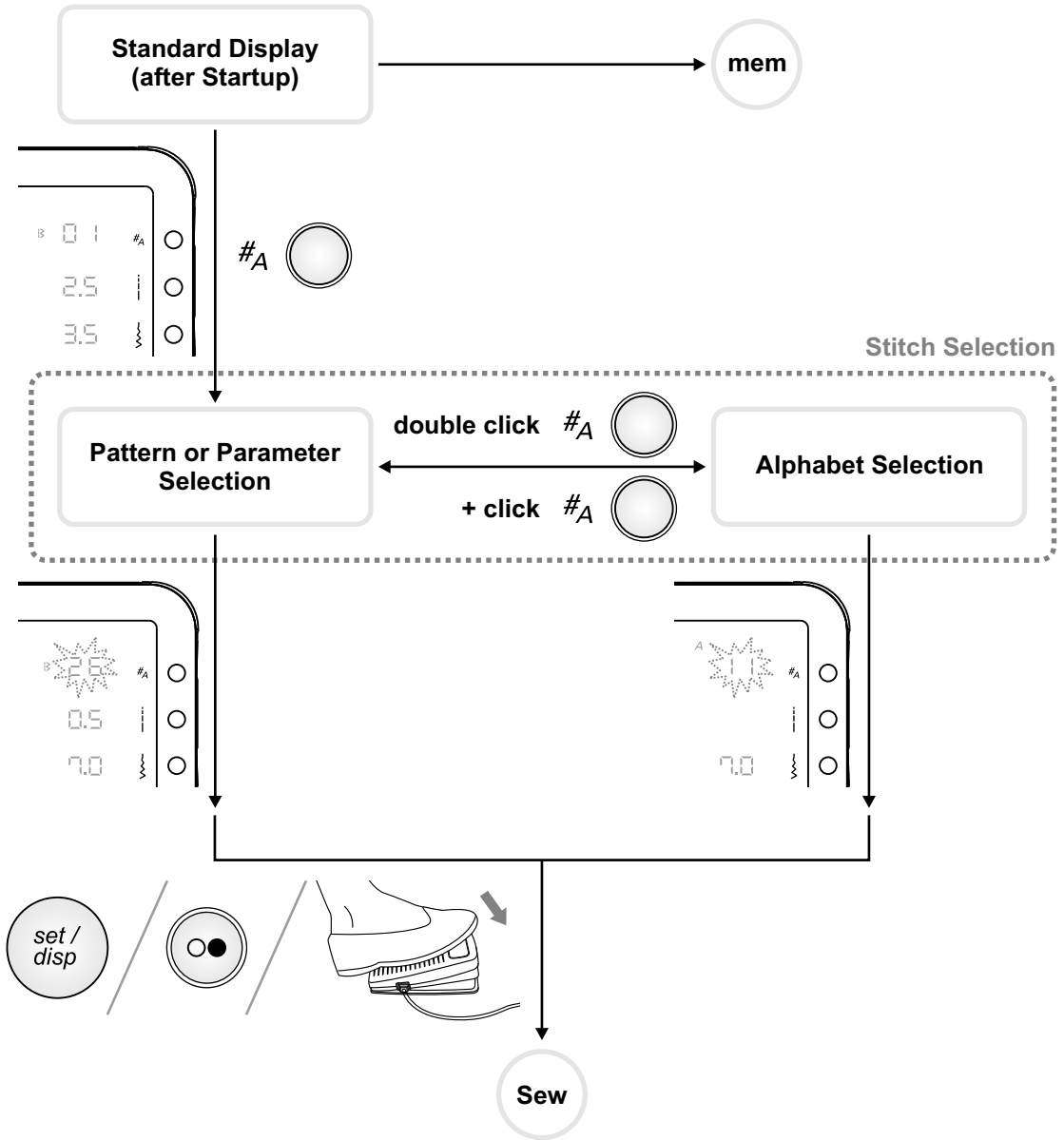

Flowchart Memory Mode

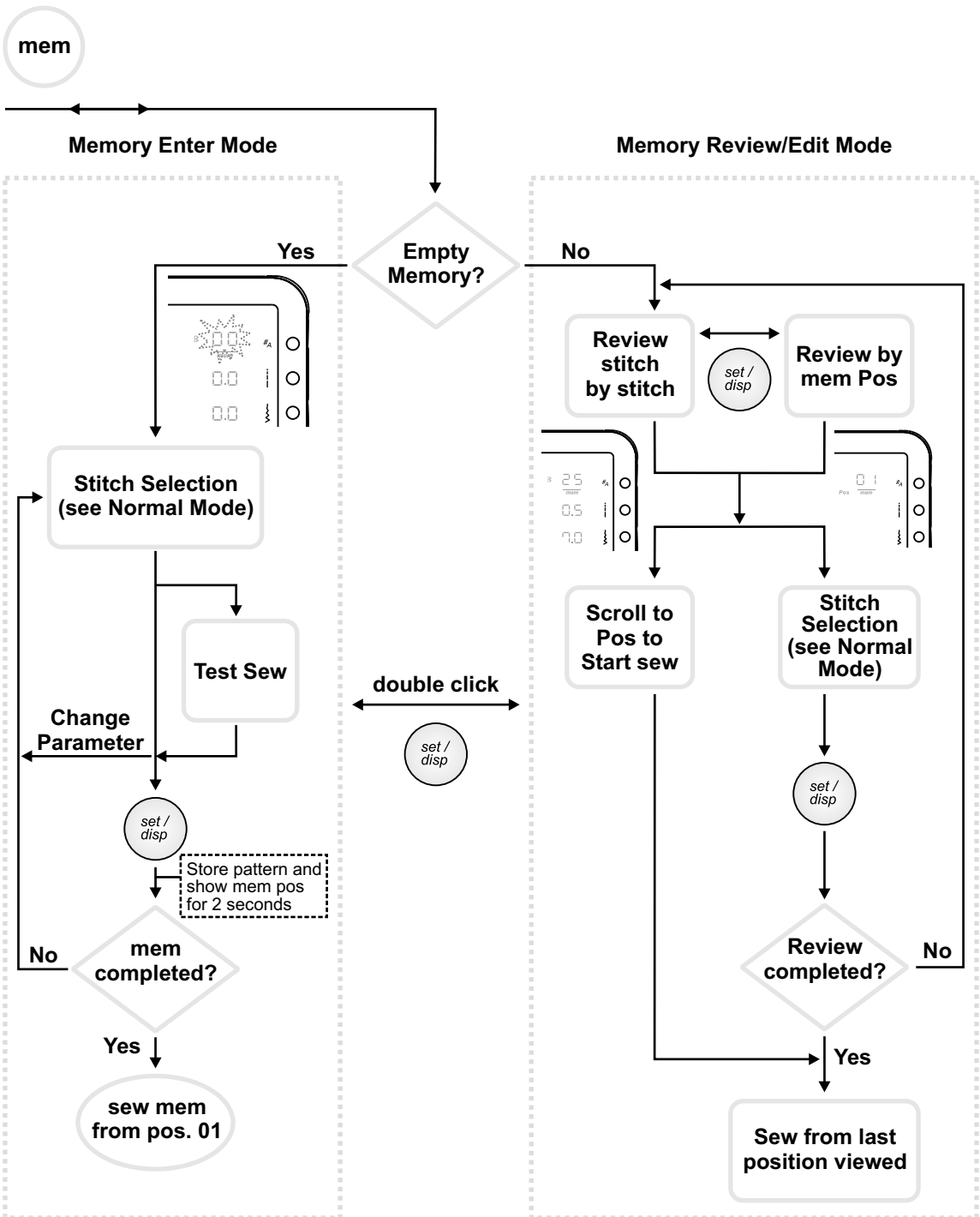

bernette
sublime

EN - 05/2013
502020.83.59 / 021H1D0101(A)
© BERNINA International AG
Steckborn CH, www.bernina.com



For more information visit
www.mybernette.com